

©2009

INSEON LEE

All RIGHTS RESERVED

DEVELOPMENTAL TRAJECTORIES OF BEHAVIOR PROBLEMS
OF YOUTH INVOLVED IN CHILD WELFARE:
INFLUENCE OF CAREGIVER AND PEER RELATIONSHIPS

by

INSEON LEE

A dissertation submitted to the
Graduate School-New Brunswick
Rutgers, The State University of New Jersey

In partial fulfillment of the requirements

For the degree of

Doctor of Philosophy

Graduate Program in Social Work

Written under the direction of

Dr. Chien-Chung Huang

And approved by

New Brunswick, New Jersey

October, 2009

ABSTRACT OF THE DISSERTATION

DEVELOPMENTAL TRAJECTORIES OF BEHAVIOR PROBLEMS OF YOUTH INVOLVED IN CHILD WELFARE: INFLUENCE OF CAREGIVER AND PEER RELATIONSHIPS

By INSEON LEE

Dissertation Director:

Dr. Chien-Chung Huang

This dissertation examines the developmental trajectories of adolescent youth involved with the child welfare system, particularly focusing on their externalizing and internalizing behavioral problems. The study on which this dissertation is based investigated how adolescents' relationships with caregivers and peers change over time and how these relationships affect their behavioral outcomes. The study also explored whether removing youth from their biological families determined distinct trajectories of behavior functioning, in comparison to that of youths who remained at home.

Data are from the National Survey of Child and Adolescent Well-being (NSCAW), a national probability sample of children and adolescents who have contact with child

protective services. Two types of structural equation modeling (SEM) – latent growth curve modeling and autoregressive cross-lagged designs – were conducted using M-Plus. All analyses were conducted with sample weights.

Youths reported significantly decreasing internalizing behavior problems over the study period of 36 months. On the other hand, externalizing problems remained considerably stable over time. Their relationships with caregivers did not change, while their peer interactions improved over time. In order to investigate if youth had differing developmental trajectories by placement status, the sample was divided into four placement groups: out-of-home youth, in-home youth, the initial out-of-home youth (those who returned home later), and the initial in-home youth (those who were removed from home later). When group differences were investigated for internalizing and externalizing problems, youths did not show significant differences in either their initial levels or in their over-time rates of change of behavior problems. In addition, relationships with caregivers and peers were found to be comparable across four groups.

Caregiver and peer relationships were significantly related to youths' internalizing and externalizing problems at baseline, as well as over time. When temporal causal relations among caregiver relationships, peer relationships, and behavior problems were investigated, externalizing problems of youth at 18 months after the close of the investigation were found to predict their later caregiver- and peer- relationships at 36 months.

Acknowledgements

Words cannot express how much I appreciate all of my committee members for their support and encouragement. Prof. Huang and Prof. Simmel, you have been great advisors, mentors and emotional supporters throughout the program as well as in the process of dissertation. You kept encouraging me to feel confident and capable. I love your smiles and good-nature. It has been such a joy to have worked with you. Prof. Peterson, thank you for adding methodological strengths to my dissertation. Prof. Siegel, I respect your knowledge on attachment theory and appreciate your critical input. I will remember all of you, as we were when our picture was taken together, warmly and for a long time, and I will smile whenever I think of you.

My beloved parents and family: you are gifts from God. I love you deeply. Thank you, my parents, for what you have done for me. Mother, your prayers have always been a great support and strength in my life. God, thank You for everything You have given me. You are sincere and Your love never changes. You are my strength. Friends, thank you for your support and prayers, and for just being my friends. In you, my family and friends, and in God, I find the reason for studying social work. Your love keeps encouraging me to look around for children and families who need love and support.

Last, I would like to thank the New York Foundling Vincent J. Fontana Center for Child Protection Dissertation Grant Program for providing me great support.

Table of Contents

ABSTRACT OF THE DISSERTATION.....	ii
Acknowledgements.....	iv
Table of Contents.....	v
List of Tables.....	vii
List of Figures.....	viii
CHAPTER 1 INTRODUCTION.....	1
Children Involved with the Child Welfare System.....	2
Developmental Trajectories of Children in Child Welfare Services.....	3
Relationships with Caregivers and Peers.....	5
Adolescence as a Vulnerable Developmental Period.....	7
Individual Variability among Abused Children.....	8
CHAPTER 2 LITERATURE REVIEW.....	9
Theoretical Framework.....	9
Attachment Theory.....	9
Risk and Resilience Model.....	15
Empirical Background.....	18
Externalizing and Internalizing Behavioral Problems.....	18
Relationship with Caregivers and Peers as Protective Factors.....	24
Research Questions & Hypotheses.....	27
CHAPTER 3 METHODOLOGY.....	32
Data.....	32
Sample.....	33

Measures.....	35
Analytic Strategies	38
CHAPTER 4 RESULTS.....	48
Sample Description.....	48
Trajectories of Youths' Behavior Problems and Relationships with Caregivers and Peers	50
Examining Growth Over Time: Unconditional Models.....	50
Testing Group Differences: Multigroup Analyses	57
Caregiver Relationships and Behavior Problems	64
Peer Relationships and Behavior Problems.....	69
Causal Relationships Among Caregiver Relationships, Peer Relationships, and Behavior Problems	74
CHAPTER 5 DISCUSSION.....	81
Summary and Interpretation of Results.....	81
Implications for Theory, Policy, and Practice.....	90
Limitations	95
Directions for Future Research	96
References.....	100
C.V.....	114

List of Tables

Table 1. Sample Description	49
Table 2. Means of CBCL, Caregiver and Peer Relationships by placement group	50
Table 3. Model Indices for Baseline Growth Curve Models	54
Table 4. Multigroup Tests for Internalizing and Externalizing Problems	60
Table 5. Factor Variances and Covariance by Placement Groups.....	60
Table 6. Multigroup Tests for Caregiver and Peer Relationships	62
Table 7. Factor Variances and Covariance by Placement Groups.....	62
Table 8. Model Fit Indices for Multivariate Growth Models.....	66
Table 9. Model tests for Internalizing Problems, Caregiver and Peer Relationships	75
Table 10. Model tests for Externalizing Problems, Caregiver and Peer Relationships	78

List of Figures

Figure 1. Baseline growth model.....	42
Figure 2. Latent growth model: The impact of caregiver relationship on internalizing behavior problems.....	42
Figure 3. Path diagram of bivariate autoregressive cross-lagged model.....	44
Figure 4. Hypothesized cross-lagged models.....	47
Figure 5. Baseline growth curve models for internalizing and externalizing behavior problems.....	56
Figure 6. Baseline growth curve models for caregiver and peer relationships.....	56
Figure 7. Multivariate growth curve model for caregiver relationships and internalizing behavior problems.....	66
Figure 8. Multivariate growth curve model for caregiver relationships and externalizing behavior problems.....	68
Figure 9. Multivariate growth curve model for peer relationships and internalizing behavior problems.....	71
Figure 10. Multivariate growth curve model for peer relationships and externalizing behavior problems.....	73
Figure 11. Final model for internalizing behavior problems, caregiver and peer relationships.....	77
Figure 12. Final model for externalizing behavior problems, caregiver and peer relationships.....	79

CHAPTER 1

INTRODUCTION

Though research on maltreated children has increased significantly over the past several decades, few studies have tracked maltreated children involved with Child Protective Services (CPS) over time. Moreover, very few studies have examined prospectively and systematically how both children removed from abusive home environments, as well as those who have remained in their home environments, fare in terms of their behavioral and psychosocial functioning, or in relationships with caregivers and peers. The study aims to examine the developmental trajectories of youths involved with the child welfare system, particularly focusing on their externalizing and internalizing behavioral problems. The current study specifically focused on adolescents, who are a particularly vulnerable group of children within the child welfare system. The study also investigated how adolescents' relationships with caregivers and peers change over time and how they affect these behavioral outcomes. The study examined whether youth placed in out-of-home care exhibit distinct trajectories from those remained in home after the close of the investigation in terms of their behavioral functioning and relationship qualities.

The study used data from the National Survey of Child and Adolescent Well-being (NSCAW), a national probability sample of children and adolescents who have contact with CPS. The sample of NSCAW was selected from children who were the subjects of child abuse and neglect investigations conducted by CPS during the sampling period.

Children Involved with the Child Welfare System

The child welfare system is a group of services designed to promote the well-being of children who are reported due to suspected child abuse or neglect. The primary functions of the child welfare system are to investigate child maltreatment reports, provide services to families at risk, arrange foster care placements or adoptions, and provide independent living services for older youth leaving foster care (Child Welfare Information Gateway, 2008; Mallon & Hess, 2005). Typically, reports of possible child abuse and neglect are received by CPS. A report may be screened out if there is not enough information to proceed, or if the situation reported does not meet the legal definition of abuse or neglect. Reports selected for further review are investigated by CPS workers and are labeled either “substantiated” or “unsubstantiated”. If a report is substantiated, children either return home and receive no services, return home and receive services, or are placed away from their parents in foster care, depending on the severity of maltreatment and the risk of future maltreatment and serious harm (Child Welfare Information Gateway, 2008; Depanfilis, 2005). Postinvestigative services may be offered to strengthen the families and ensure the safety of children. The services include individual counseling, case management, family-based services, in-home services, and foster care services. Foster care includes family foster homes of nonrelatives, foster homes of relatives, group homes, residential facilities, preadoptive homes, emergency shelters, and childcare institutions (U.S. Department of Health and Human Services, 2008a).

During 2006, an estimated 3.3 million referrals, involving 6.0 million children, were made to CPS agencies. Approximately 3.6 million children were investigated and an

estimated 905,000 children were found to be victims of abuse or neglect. Nearly 60 percent of child victims received postinvestigation services. An estimated 312,000 children were removed from their homes as a result of a child maltreatment investigation (U.S. Department of Health and Human Services, 2008a). More than half a million children are currently in foster care, with approximately 300,000 children entering and exiting care each year (U.S. Department of Health and Human Services, 2008b).

Children involved with CPS are generally at high risk for behavior problems, whether or not they are placed in out-of-home care. Children involved in the child welfare system may have developmental outcomes and relationship experiences that are different from maltreated children in a community population. Though studying maltreated children in a general population is necessary in order to assess the prevalence of maltreatment not reached by CPS (and so develop prevention programs with which to combat the problem), it is urgent and critical to ensure that children in the child welfare system fare well over time. However, with a great number of CPS-involved children at high risk for developmental problems, we know little about how these children function in the long-term. This study aims to fill important gaps in maltreatment research by examining developmental trajectories of children involved in the child welfare system. Specifically the present study has significance as follows.

Developmental Trajectories of Children in Child Welfare Services

An extensive body of literature suggests that childhood maltreatment is associated with negative outcomes across multiple domains of functioning (Manly, Kim, Rogosch, & Cicchetti, 2001; Cicchetti & Carlson, 1989; see Margolin & Gordis, 2000; Veltman & Browne, 2001; Putnam, 2003; Kaplan, Pelcovitz, & Labruna, 1999, for

review). However, though literature exists about long-term outcomes for maltreated children (e.g., Horwitz, Widom, McLaughlin, & White, 2001; Lansford et al., 2006; Kim & Cicchetti, 2006; Jonson-Reid, Drake, Kim, Porterfield, & Han, 2004; Stouthamer-Loeber, Loeber, Homish, & Wei, 2001; Thornberry, Ireland, & Smith, 2001; Simmel, Barth, & Brooks, 2006; Smith & Thornberry, 1995), there has been relatively little research investigating how maltreatment experience influences developmental trajectories over time. In addition, much of extant literature on long-term outcomes is based on retrospective reports of adults, and prospective evidence is sparse (Cohen, Brown, & Smaile, 2001). One unresolved debate among those concerned about the well-being of maltreated children is whether children fare better with biological parents or away from them (Doyle, 2007). Though extant studies on maltreated children suggest that foster care children are at higher risk for poor outcomes (Orme & Buehler, 2001), few studies compare children in home and children in foster care prospectively and systematically. Most research on foster care outcomes is typically based on the reports of adults who spent time in foster care, or on children who have been in foster care for a considerable time, and have not taken into account their psychological well-being before the placements. This limitation of previous studies makes it difficult to investigate the contribution of foster care to children's outcomes (Wulczyn, Barth, Yuan, Jones Harden, & Landsverk, 2005). Moreover, most of the previous studies compare children in foster care with nonmaltreated children (e.g., Kortenkamp & Ehrle, 2002; Buehler, Orme, Post, & Patterson, 2000; Farruggia, Greenberger, Chen, & Heckhausen, 2006; Halfon, Berkowitz, & Klee, 1992; Hulsey & White, 1989; McIntyre & Keesler, 1986).

Further study is necessary to explore the characteristics of abused children placed

in home and out of home at intake, and their developmental trajectories over time. The deficiency in the research can be solved partly with NSCAW. NSCAW involves a national representative sample of children and families touched by the child protection system. It provides comprehensive and long-term information on children who entered foster care and those children who were referred but did not enter foster care. The analysis of this longitudinal survey will offer essential information on children in child welfare system.

Relationships with Caregivers and Peers

While previous studies have found that abused children, especially foster care children, are likely to have high interpersonal problems (e.g., Bolger & Patterson, 2001; Darwish, Esquivel, Houtz, & Alfonso, 2001; Cook-Fong, 2000; Buelher et al., 2000; Shields, Ryan, & Cicchetti, 2001; Dodge, Pettit, & Bates, 1994; Haskett & Kistner, 1991; Salzinger, Feldman, Hammer, & Rosario, 1993), little systematic research has examined how the quality of children's relationships with caregivers (either permanent caregivers or foster caregivers) and peers change and interact reciprocally with child outcomes over time. For children in general, the mother-child relationship has been found to be vital to the development of child behavior and psychological functioning (Bowlby, 1969). A child's biological parents (especially the mother) represent a figure that protects children from outside harm and threats. However, in the case of child maltreatment, a mother can likely be the source of fear, harm, and/or negligence (Main & Hesse, 1990). In this context, children moved from a damaging environment to a supportive foster home may develop healthy attachment relations, which subsequently are likely to mitigate the negative effects of maltreatment. It is important to examine how the relationship between

a child and a caregiver change over time when the child remains in home and when the child is placed in foster care settings, and how the child's relationships with caregivers are associated with child developmental function.

On the other hand, though relationships with parents are important to child development, children increasingly interact with others outside the family as they get older. In particular, adolescence is a period during which individuals formulate intimate relationships outside the family and become less dependent on their parents (Scannapieco & Connell-Carrick, 2005; Wood, Read, Mitchell, & Brand, 2004; Ryan, 2001; Laible, Carlo, & Raffaelli, 2000; Fraley & Davis, 1997; Garnezy, Masten, & Tellegen, 1984; Noom, Dekovic, & Meeus, 1999). Peer groups are likely to have an increasing influence on their emotional, behavioral, and social functioning, and sometimes are a greater influence than parents (Scannapieco & Connell-Carrick, 2005; Wulczyn et al., 2005; Ryan, 2001; Simons-Morton, Haynie, Crump, Eitel, & Saylor, 2001; Windle, 2000; Larson & Richards, 1991; Paikoff & Brooks-Gunn, 1991). Children's peer relationships have been reported to attenuate the negative effects of family adversity (Bolger, Patterson, & Kupersmidt, 1998; Criss, Pettit, Bates, Dodge, & Lapp, 2002).

While it is posited that foster care children are likely to experience additional trauma by being removed from their family, friends, and schools (Taussig, 2002), evidence based on systematic research of children's relationships dynamics is rare. Particularly lacking is systematic research on the foster youths' relationships with peers and key adults in their lives (Farruggia et al., 2006). Further study needs to explore and compare the relationships dynamics over time systematically in these groups.

Adolescence as a Vulnerable Developmental Period

Children at different points in development may have different responses to the same maltreatment incident, and the same incident may have different outcomes on children in different paths of development (Cicchetti & Rogosch, 2002). Therefore, age must be considered to understand how a child's experience of maltreatment, and subsequent experience in the child welfare system, affects her functioning in both the short-term and long-term. Most studies previously conducted did not examine age-specific patterns in sample groups with children of widely varying ages, due to the small sample and methodological limitations (Keiley, Howe, Dodge, Bates, & Petti, 2001). Extant age-related studies have focused on children who had been maltreated during early developmental periods; fewer studies have examined the developmental effects of maltreatment on adolescents (Wulczyn et al., 2005). Adolescence is characterized by age-related life tasks and challenges across multiple domains such as pubertal onset, creating a self identity and autonomy, greater involvement with peers, as well as increases in internalizing and externalizing problem behaviors (e.g., depression, substance use, delinquency, sexual activity) (Windle, 2000; Wulczyn et al., 2005; Holmbeck & Kendall, 2002). Maltreated adolescents are a particularly vulnerable population as they not only experience traumatic incidents of maltreatment but also confront complex developmental challenges and changes. Evidence suggests that adolescents in child welfare show more behavior problems and experience a higher rate of placement changes than children in middle childhood when placed out-of-home (Wulczyn et al., 2005). To meet the needs of this vulnerable population, it is essential to investigate the characteristics of maltreated children in this development period and adopt strategies that are tailored to this age.

Individual Variability among Abused Children

Though in recent years researchers have become increasingly interested in resilience in maltreated children (Toth & Cicchetti, 2006), the extant empirical literature has extensively documented negative outcomes associated with maltreatment and limited literature addresses well-adapted children (Cicchetti, Rogosch, Lynch, & Holt, 1993; McGloin & Widom, 2001). Even though children who have experienced maltreatment are at high risk of negative outcomes, some of these children are well adapted. Human beings continuously interact with their environment, and the long-term effects of child maltreatment are likely to vary among all individuals. Despite variability among abused children, previous studies have focused on maladjustment of abused children as a universal group, and have disregarded individual differences (Haskett, Nears, Ward, & McPherson, 2006; Cicchetti et al., 1993). Moving from the deterministic point of view that child maltreatment has life-long influence, notice of individual variability, and of how risk and protective factors interact and lead to certain results, are to be encouraged. There is especially a great need for longitudinal studies of positive adaptation among maltreated children as a child's resilient functioning and factors related to it may not be sustainable over time (Haskett et al., 2006). This study seeks to investigate the variability in developmental trajectories of abused children, particularly by focusing on risk and the protective role of children's relationships.

CHAPTER 2

LITERATURE REVIEW

Theoretical Framework

Attachment theory and risk and resilience models both provide useful frameworks for this study's research questions and hypotheses.

Attachment Theory

Attachment theory has been influential in the literature on the effects of disrupted early parent-child relationships on children throughout life. Attachment theory's origins lie with Bowlby's landmark work to understand the maladaptive functioning of children who had experienced early parental loss or separation (Bowlby, 1969, 1973, 1980). According to attachment theory, a child develops an attachment pattern/schema through interactions with an early caregiver. A child feels secure when their attachment figure is responsive, protective and available when s/he needs her/him. If an infant feels security in her/his relationship with her/his early caregiver (which is mostly her/his mother), s/he can use her as a "secure base" from which s/he can explore and learn their environment and other people in it (Ainsworth, 1967). S/he dares to leave her/his parents and risk insecurity and anxiety that her/his exploration may cause because s/he trusts her/his parents to be available when s/he needs them for support and protection (Ainsworth, Blehar, Waters, & Wall, 1978). Bowlby (1969, 1973) suggests that development of attachment is closely connected with cognitive development. That is, individuals build internal working models of self, the attachment figure, and the world with which s/he perceives and predicts behaviors and responses of others and plan her/his behaviors and

responses. According to Bowlby, the attachment figure plays a key role in constructing one's internal working models. The internal working model also serves to regulate an individual's behavior in later interpersonal relationships. A child that is cared for by an affectionate caregiver builds expectations that others are accessible and responsive, and feels confident in relationships with others. Subsequently, the relationship that a child experiences with early caregivers strongly affects the child's socioemotional development and ability to develop secure relationships with others throughout life (Bowlby, 1979; Sroufe & Fleeson, 1986).

Mary Ainsworth's work has contributed to the understanding of early childhood attachment. Ainsworth and her colleagues developed 'Strange Situation', a standardized laboratory procedure which consists of several episodes. In the Strange Situation, the infant is observed with her/his mother in the unfamiliar room for some minutes, to see how the child would react. First, when the mother is still present, a stranger is introduced in the unfamiliar environment and approaches the baby. Immediately after the introduction of the stranger, the mother leaves the room. The combined separation from the mother and presence of a stranger cultivates stress in the infant, which are observed. For one year prior to the Strange Situation assessment, infants and their mothers are observed at home, in order to examine the relationship between the behavior of infants while in the Strange Situation and that displayed while in interaction with their mothers at home (Ainsworth et al., 1978).

It has been suggested that infants develop four different attachment styles based on interactions with their primary caregivers: secure attachment (group B), insecure-avoidant (group A), insecure-ambivalent (group C), and disorganized/disoriented (group

D) (Ainsworth et al., 1978; Main & Solomon, 1986). Securely attached infants (group B) show less frequent distress when their mothers leave and positively greet and seek contacts with their mothers upon the reunion. Infants develop secure attachment when they experience sensitive and responsive caregiving. Mothers of infants in this group are promptly responsive to infant behavioral signals and show affectionate behavior to them. Securely attached infants tend to be more socialized, cooperative and competent than infants who are insecurely attached. Insecure-avoidant infants (group A) express little or no distress when mothers leave, and avoid or resist mothers when they return. They treat strangers in the same way as, or more favorably than they treat their mothers. The mothers of this group are found to be more rejecting than the other groups, and tend to be angry, rigid and compulsive. Insecure-ambivalent infants (group C) express significant distress when their mothers leave. When their mothers return, these infants show ambivalence by simultaneously seeking proximity to the mother and expressing angry resistance to reconciliation. Insecure-ambivalent attachment is developed when infants have experienced insensitive care. Mothers are not rejecting or lacking in physical contact and emotional expression like group A mothers. However, they are much less responsive and more inconsistent than group B mothers, and their physical contact and emotional expression are not as consistently positive as in group B mothers.

Disorganized/disoriented attachment type (group D) was categorized later by Main and Solomon (1986) for infants showing behavior characteristics that did not fit these three categories. Infants in this group have no organized strategy to deal with separation and reunion and show contradictory behavior patterns. For example, when mothers return, some infants greet them, while others show angry behavior. They then

immediately turn away, and show dazed behavior and display indices of confusion and nervousness. Disorganized/disoriented attachment results from disruptive or abusive interactions with an attachment figure. Whereas an attachment figure is assumed to function as a source of protection, infants who are exposed to abuse are placed in a conflicted situation because the mother is simultaneously the source of fear and threat and the source of protection (Main & Hesse, 1990). Empirical studies have reported that maltreated infants are likely to form disorganized/disoriented attachments to their abusive caregivers (Carlson, 1989; Lyons-Ruth & Jacobvitz, 2008). Mothers with affective disorders or unresolved loss increase the likelihood of disorganized children. The disorganized/disoriented infants have been documented to be associated with a variety of adjustment difficulties and to psychopathology (Carlson, 1998; Shaw, Owens, Vondra, Keenan, & Winslow, 1996; Lyons-Ruth & Jacobvitz, 2008).

Though Bowlby emphasized that early attachments play a key role in a child's developmental function and subsequent close relationships, he also argued that individual functioning is always the output of interaction between early experience and current environment. Mother and child attachment may still be impactful, but may be reversible as the child continues to establish new relationships with others. Crittenden and Ainsworth (1989) suggested that a child accepts new experiences and revises his internal working model accordingly as he constructs new relationships and finds a more responsive substitute attachment figure; therefore, the attachment system is an "open model" which is adjustable to new input, or revised by reconstruction of past input.

Though early experience is likely to play a critical role on developmental process of children, there is evidence that the attachment system can be reorganized. Though little

literature examines relationship formation in atypical children who have maltreatment history, studies suggest that children with prior disrupted relationships can form secure attachment relationships with new caregivers. For example, Dozier and her colleagues (Dozier, Stovall, Albus, & Bates, 2001) found that foster care infants who experienced disruptions in their relationships with previous caregivers were able to form secure attachments to nurturing foster caregivers. In the study, about half of the infants in foster care were classified as secure, which was similar to the proportion seen among normal samples. Similarly, many abused children built secure attachments to nonabusive parents and caregivers despite having anxious attachments to their abusive parents (Lamb, Gaensbauer, Malkin, & Schultz, 1985). In a longitudinal study by Sternberg and colleagues (Sternberg, Lamb, Guterman, Abbott, & Dawud-Noursi, 2005), abused adolescents showed significantly lower levels of secure attachment styles to their mothers than nonabused children. Interestingly abuse experienced 5-6 years earlier had no discernible impact on adolescents' current perceptions of their attachment style. This finding indicates that children's perceptions of attachment can change over time depending on concurrent change in the quality of interaction (Sternberg et al., 2005; Sroufe & Fleeson, 1986). If the attachment system is assumed to be an open model, children with prior relationship difficulties may be able to reorganize their internal representation model or construct attachment relationship when they encounter sensitive caregivers.

Most attachment research has focused on the child-mother attachment relationship. Also, the study of attachment has been limited to the early childhood period, and attachment behaviors that occur during adolescence and adulthood have been

relatively unexplored (Wilkinson & Walford, 2001; Laible et al., 2000; Allen et al., 2002; Field, 1996). Children encounter alternative attachment figures at varying points in their development. Particularly in adolescence, children actively search for new attachments outside the family (Laible et al., 2000; Scannapieco & Connell-Carrick, 2005; Crittenden & Ainsworth, 1989). Howes (2008) indicated the importance of investigating relationship formation in atypical children who have problematic relationship histories. Children with prior disrupted relationships tend to experience difficulty in constructing new relationships; nevertheless, they are likely to build secure relationships when the caregivers are very sensitive and caring towards them (Howes, 2008). A set of possible alternative caregivers includes foster and adoptive parents, shelter and group home caregivers.

On the other hand, in response to the expansion of research beyond the mother-child relationship, there have been studies which have emphasized the importance of peers. Harris (1998) suggested that a child's peers have more influence on shaping child's character and later mental health than their parents. Peers affect a child's social development by providing social support, feelings of shared intimacy and loyalty, as well as opportunities to learn and imitate strategies that are different from those used with adults (Scannapieco & Connell-Carrick, 2005; Lieberman, 1977; Lee, 1975; Lewis & Rosenblum, 1975). In addition, a child's peer relationship has significant association with emotional and behavioral adjustment (Lopez & Dubois, 2005; Ladd & Troop-Gordon, 2003; Goldstein, Davis-Kean, & Eccles, 2005; Masten, 2005; Allen, Porter, McFarland, & Marsh, 2005; Simons-Morton, 2001; Windle, 2000; Vitaro, Pedersen, & Brendgen, 2007; Parker & Asher, 1987; Parker, Rubin, Erath, Wojslawowicz, & Buskirk, 2006; also

see Deater-Deckard, 2001, for review) and school engagement and academic achievement (Ryan, 2001; Wentzel & Caldwell, 1997; Furrer & Skinner, 2003; Ladd & Price, 1987).

Researchers have also pointed out the need to investigate how the child-parent attachment influences a child's relationships with its peers. Lieberman (1977) suggested that security of attachment and peer interactions might be related to each other. Further attachment research needs to examine the interactions among the influences of these various relationships (Berlin & Cassidy, 1999). As Berlin and Cassidy pointed out, children's interactions with peers and nonparental adults may contribute to increase or decrease their attachment to their parents. Investigation of these relationship interactions will expand our understanding of child attachment and its influence, particularly on abused children.

Risk and Resilience Model

Despite such devastating life events as child maltreatment and separation from family, some children fare well; others, however, get worse as a result. The risk and resilience model helps explain this individual variation. Resilience refers to a "*dynamic process encompassing positive adaptation within the context of significant adversity*". Implicit within this notion are two critical conditions: (1) exposure to significant threat or severe adversity; and (2) the achievement of positive adaptation despite major assaults on the developmental process" (Luthar, Cicchetti, & Becker, 2000, p.543). That is, individuals are considered resilient if they show competent functioning despite the existence of risk factors that significantly are associated with negative outcomes. There is variability in defining or measuring resilience (Luthar et al., 2000; Masten, 2001; Luthar & Cushing,

1999). Resilience has been defined and measured on indicators of externalizing adjustment/symptomatology (e.g., behaviors, academic achievement, delinquency), internalizing adjustment/symptomatology (e.g., psychological well-being, depression, distress) or both (Masten, 2001; Windle, 1999).

The situation of adaptive individuals facing adversity began to receive attention in 1970's with the studies of scholars including Norman Garmezy. In his studies, Garmezy found adult schizophrenics and children of schizophrenic mothers who fared well despite disadvantages (Garmezy, 1970; Garmezy, 1974). The landmark work of Emmy Werner spurred research on resilience. Her research traced long-term development and adaptation of high-risk children and identified protective factors that buffered children against adversity, in her longitudinal study of Kauai children in Hawaii (Werner, French, & Bierman, 1971; Werner & Smith, 1977). For example, one of the significant protective factors revealed in this study was the presence of nonparental adults in children's lives, such as peers and elders in the community, and teachers (Werner, 1995). In her study she found that well-adjusted children, despite family instability and poverty, had had an important adult in their lives.

Before resilience was recognized, early studies of children in disadvantaged circumstances (such as child maltreatment, poverty and family disruption) had focused on risk factors and consequent negative and maladaptive outcomes. Much less attention was paid to the adaptive abilities of such children. The assumption underlying this approach was that adverse life events or disadvantaged conditions resulted in negative outcomes. This approach, thus, viewed developmental process as somewhat deterministic (Cicchetti & Garmezy, 1993). The rise of the resilience model has overturned the inevitable deficit

model that focused exclusively/primarily on maladaptation in children in adversity (Masten, 2001). Recent research has increasingly emphasized resilience. Whereas adaptive children were regarded atypical and extraordinary cases in early research of risk and psychopathology, resilience is found to be ordinary and more common than is often believed among disadvantaged children (Masten, 2001).

Why do resilient children fare well despite adversity? Research on resilience has attempted to identify factors that are related to positive outcomes in the presence of adversity. Three sets of protective factors were identified: 1) attributes of resilient children themselves (e.g., autonomy, self-esteem, intelligence), 2) family factors (e.g., quality of parenting, substitute caregivers within the extended family), and 3) extrafamilial factors (e.g., peers, teachers, supportive adults, church, community activities) (Fraser & Terzian, 2005; Luthar et al., 2000; Werner, 1995). Though there are different perspectives that explain how these multiple factors lead to the development of an individual's resilience, there is general agreement that these individual characteristics and environmental factors reciprocally interact to influence and shape child's functioning (Luthar et al., 2000). From this perspective, researchers also have emphasized an understanding of underlying *protective processes* rather than simply identifying protective/risk factors (Luthar et al., 2000; Rutter, 1987; Werner, 1993).

The resilience model has been utilized in a growing number of studies on maltreated children. Maltreated children are exposed to considerably higher risk and adversity as they are characterized by disruption of the caregiving environment, which is known to be a strong protective factor in the face of stress and a disadvantaged environment. Empirical studies generally agree that maltreatment has a deleterious

impact on children, across myriad domains of development. However, research has found that children are not uniformly affected by the experience of maltreatment and, moreover, that some maltreated children show adaptive functioning despite the significant adversity they have experienced (Cicchetti & Toth, 2000; see, e.g., Cicchetti et al., 1993; Moran & Eckenrode, 1992). Still, much less research has been done into understanding factors that contribute to positive adaptation in this population and, more importantly, into the underlying processes and mechanism within which these factors may lead to various child outcomes (Cicchetti & Toth, 2000; Kaplan et al., 1999). In order to develop effective intervention methods for maltreated children, research needs to focus on the pathways and variables that result in resilient outcomes among some individuals.

Empirical Background

The present study focuses on maltreated youth involved with child welfare agencies. Therefore, the following review will focus on this population, and not all maltreated children.

Externalizing and Internalizing Behavioral Problems

Previous studies have documented the prevalence of emotional and behavioral problems among youth involved with child welfare agencies (e.g., Burns et al., 2004; Farmer et al., 2001; Pilowsky & Wu, 2006; Harman, Childs, & Kelleher, 2000; McMillen et al., 2005; McIntyre & Keesler, 1986; Urquiza, Wirtz, Peterson, & Singer, 1994). For example, when compared with nonmaltreated children, children referred to CPS were significantly associated with impaired behavioral functioning (Manly, Cicchetti, & Barnett, 1994). Trupin and colleagues (Trupin, Tarico, Low, Jemelka, McClellan, 1993)

investigated emotional disturbance of 191 children aged 3 to 18 years who were served by CPS in Washington State; over 70% of the children were classified as SED (Serious Emotional Disturbance). In a recent study using NSCAW, a national sample of children who have had contact with CPS, nearly half of the children aged 2 to 14 years (N = 3,803) scored in the clinical range of the Child Behavior Checklist (CBCL; Achenbach, 1991), indicating significant emotional or behavioral problems in this population (Burns et al., 2004). In another study using NSCAW, Stahmer et al. (2005) examined behavior problems of young children (ages 2 to 5) based on level of CW (child welfare) involvement at the time of initial interview (i.e., placed out of home, in home with active CW case, or in home with no active CW case). About one third of the children scored in the clinical range of the CBCL, and the level of risk was not significantly different by the 3 levels of CW involvement.

Most studies of children who have had contact with CPS focus on children removed from home and placed in kin or nonkin foster care (see Kerker & Dore, 2006; Simms, Dubowitz, & Szilagyi, 2000, for review). One of the earlier studies examined long-term change in child functioning in foster care youth. In a five-year longitudinal study on a large sample of foster care children aged 0 to 12 years (N = 624) (Fanshel & Shinn, 1978), children showed more behavioral problems over time while in foster care. A number of subsequent studies have investigated behavioral problems and the mental health needs of children in foster care by using the CBCL (see Heflinger, Simpkins, & Combs-Orme, 2000, for review). These studies have documented a prevalence of emotional and behavioral problems in foster children. For example, in a study of 158 foster care children aged 4 to 18, nearly half of the sample, regardless of gender or age

group, showed clinical psychological disorders on the narrow band index of CBCL (McIntyre & Keesler, 1986). The study by Urquiza et al. (1994) also reported high rates of cumulative mental health risk of children entering foster care (N = 167). Nearly a third of the sample scored in the clinical range on the CBCL, with no significant difference on the basis of gender or ethnicity. Other studies of children in foster care have presented that about one third of the children score in the clinical range for internalizing and externalizing behavior problems (Clausen, Landsverk, Ganger, Chadwick, & Litrownik, 1998; Heflinger et al., 2000; Zima et al., 2000). In a recent study using NSCAW, nearly half of the children placed in foster care more than one year (N = 462, ages 2-15) were found to score in the clinical range on internalizing and externalizing scales (Leslie, Hurlburt, Landsverk, Barth, & Slymen, 2004). The authors suggested that the behavior problems in clinical or borderline range of CBCL were much higher than the rate expected in a community population. However, the interpretation of results from these studies needs caution because these studies did not have control groups and investigated child functioning at a single point of time (with exception of the study of Fanshel and Shinn, 1978).

Some studies have compared foster care samples with matched control groups, or with children in the community population. These studies have presented mixed results. For example, using data from the 1997 and 1999 National Survey of American's Families (NSAF), a nationally representative household survey, Kortenkamp and Ehrle (2002) compared foster children with all children in biological parental care, and also with at-risk children living in low-income single-parent families. Foster care children showed more emotional and behavioral problems than all children living with parents and at-risk

children. Similarly, children with a history of foster care placement were found to have a higher prevalence of mental health problems than those never placed in foster care (Pilowsky & Wu, 2006; Farmer et al., 2001). However, some studies have shown no difference between foster care youth and comparison youth. For example, Hulseley & White (1989) compared behavior scores of children in foster care with a control group having a similar socioeconomic status (N = 65). Foster care children manifested significantly higher scores on CBCL than the control group but the magnitude was not large. After controlling for group differences in family characteristics such as family structure and stability, significant differences between the two groups disappeared. Buehler et al. (2000) examined long-term association of foster care and adult functioning. Using data selected from the 1988 National Survey of Families and Households, the authors compared adults experiencing foster care before 19 years, adults selected at random, and adults matched to those experiencing foster care on several background characteristics (N = 303, average age is 39). There were no significant differences among the three groups on mental health as measured by depression and self-esteem. A recent study by Farruggia et al., (2006) presented similar findings. When 163 older youth participating in foster care for at least one year and a matched sample of 163 were compared (17 years of age or older), foster care youth did not differ from the comparison group in terms of depression, self-esteem, and problem behavior.

There also have been studies investigating the association of placement type and child outcomes. Though some evidence has suggested that children in kinship care do better than those in nonkinship care while they are in out-of-home care (e.g., Keller et al., 2001), other studies have not found a difference between the two groups (e.g., Benedict,

Zuravin, & Stallings, 1996). For example, Keller et al. (2001) compared behavior problems of children in kinship care with those in nonkinship care and those selected from general population (N = 240). Children in nonkin care scored significantly higher on CBCL scores than the other two groups. No differences were found between children in kin care and those from the general population. However, the initial behavior functioning of kin and nonkin was not controlled in these studies, which makes comparison between the two groups difficult.

In a prospective study, Benedict et al. (1996) examined the association between out-of-placement type (kin or nonkin) and functioning of 214 adults formerly in care (ages between 19 to 31 years). Multivariate analyses revealed that adults formerly in kinship care did not differ from those formerly in nonkinship care in terms of their current mental and emotional health outcomes. As well, neither age nor gender was found to be significant. However, behavioral problems prior to placement in out-of-home care proved to be significantly associated with later adult outcomes. This finding suggests that behavioral functioning prior to entry into care may have been related to behavior problems in children during the care and their later adaptation.

Several studies investigated factors associated with behavioral adaptation in foster care children. Using longitudinal data of children entering foster care in Connecticut (N = 120) from 1992 through 1993, Horwitz, Balestracci and Simms (2001) examined changes in the behavioral functioning of young children (aged 1 to 6 years) over one year after entry into foster care. The findings manifested that young children's functioning improved over time. Multiple regression analysis indicated that being older at placement, female, of African American ethnicity, and having spent more time in foster

care were all associated with improvement on their behavioral functioning, controlling for the baseline functioning. In a prospective study of 415 youth between ages of 0 and 17 in California, Newton, Litrownik, and Landsverk (2000) examined the relationship between placement history and behavioral problems over one year. Initial externalizing behavioral problems were found to strongly predict multiple placement changes, which were negatively related with both internalizing and externalizing behavioral problems. The findings suggested that the children's initial functioning might contribute to later behavioral adaptation as well as multiple placement changes which were likely to accelerate the negative behavioral functioning.

As noted, research on behavioral problems of children served by child welfare agencies has focused primarily on youth placed in out-of-home care. Little is known about how the majority of children remaining in their homes fare over time after their contact with the child welfare system. In a prospective study on family reunification, Taussig, Clyman, and Landsverk (2001) compared behavior problems of former foster care children who reunified with their biological families and those who remained in foster care. After six years, reunified youth showed more internalizing behavior problems and lower competence though there was no significant difference in externalizing behavior problems between two groups. Controlling for baseline behavior problems, reunification was a significant predictor of negative behavioral outcomes. As the authors implied in the study, this indicates the possibility that inadequate parenting, which leads to out-of-home placement, continues after reunification. This is supported by empirical findings of high rates of re-abuse among children reunified with biological caregivers (Farmer et al., 2001; Runyan & Gould, 1985; Terling, 1999; Wald, Carlsmith, &

Leiderman, 1988).

Though the study by Taussig et al. (2001) was not specifically aimed at children remaining in-home after CPS investigation, the findings suggest the possibility that children remaining in-home may continue to experience behavioral problems and inadequate parenting. Though children remaining in-home may not be at risk to the level as children removed from home, they represent a particularly vulnerable population due to the severity of maltreatment which has led to the filing of official maltreatment reports. Research is needed to explore how the majority of children remaining in-home fare with their biological families over time. As noted in literature review, practically no study has focused on the systematic and prospective comparison of children removed from the abusive environment with those who were not, controlling for prior functioning which proved to be associated with later adaption. Due to this significant lack of study, it is hard to determine whether a prevalence of negative functioning in foster care youth results from maltreatment or foster care placement. The limitation in previous research indicates a need in child welfare research. Research should examine whether child functioning improves or declines over time after contact with the child welfare system, and whether there are substantial differences in the long-term adjustment of maltreated children placed in out-of-home care as compared to children living with their biological parents.

Relationship with Caregivers and Peers as Protective Factors

Though it has been documented that children's relationships with parents, nonparental adults, and peers have significant associations with developmental outcomes such as behavioral and emotional problems, delinquent behaviors, and school performance in both maltreated children (Bolger et al., 1998; Haskett et al., 2006;

Lansford et al., 2006; Salzinger, Rosario, & Feldman, 2007; Toth & Cicchetti, 1996a; Toth & Cicchetti, 1996b) and nonmaltreated children (Furrer & Skinner, 2003; Ladd & Price, 1987; Parker & Asher, 1993; Vitaro et al., 2007; Wentzel, 1991; Wentzel & Caldwell, 1997), the research that focuses specifically on children in the child welfare system is very limited.

Several studies have investigated connections between foster care youths' relationships with biological or foster caregivers and their behavioral functioning. From the attachment theory framework, Marcus (1991) and Milan and Pinderhughes (2000) examined the association between children's relationships and their adjustment in foster care. In his study of 52 foster children, Marcus (1991) reported that the positive quality of relationships with foster parents and peers was associated with lower children's internalizing and externalizing behavior problems. Interestingly, quality of relationships with biological parents was generally not related to children's behavioral problems for this sample.

Milan and Pinderhughes (2000) examined how children's maternal and self representations affected both subsequent relationships with foster mothers and behavioral adaptation one month after entering foster care. In the sample of 32 children (ages 9 to 13), children's self-representations and relationship with their biological mothers predicted their subsequent relationships with foster mothers. Children's scores on the internalizing and externalizing behavioral symptoms did not differ by ethnicity or age, but girls showed significantly more internalizing behavior problems and less externalizing problems than boys. Children's behavior while in foster homes was associated with severity of maltreatment, their self-representations and relationship with

biological mothers, and their relationships with foster mothers. Though the two studies were limited to a small sample and short-term examination, the study illustrated the importance of relationship with significant adults and peers in the development of maltreated children.

Using a relatively large sample of foster care youth and a matched sample (N = 326), Farruggia and colleagues (2006) examined how foster youth perceived their relationships with significant others and how their relationships affected their well-being. Foster care youth reported lower level of support from their biological parents but more support from their important nonparental adults and peers compared to comparison sample. Their perceived relationships, particularly with important nonparental adults, were associated with adolescent outcomes in foster care. The results, consistent with previous studies, illustrated the important role of significant adults and peers on foster care youth.

Chapman, Wall, and Barth (2004) used a long-term foster care sample from NSCAW to examine the experiences of children placed in out-of-home care for at least one year. Overall, children reported high levels of relatedness to their out-of-home caregivers, and their feelings of relatedness did not differ by placement type. In a study of the sample drawn from Wave 1 NSCAW data (Wall & Barth, 2005), feelings of relatedness to caregivers were associated with delinquent behaviors. Differences by out-of-home placement status and long-term association were not investigated in this study.

The studies discussed above emphasize the importance of positive relationships with significant adults and peers as well as biological parents. When biological parents do not provide adequate parenting or are not available, significant adults (likely, foster care

parents, in the case of foster children) and peers seem to play a major role to offset the loss and trauma that foster children may experience. Literature has emphasized that foster children are likely to experience difficulties with interpersonal relationships and thus, consequently, developmental maladaptation; it is necessary that research departs from this deficit-focused approach and instead examine foster children's resilience in terms of their relationships with foster caregivers and peers (Farruggia et al., 2006).

Research Questions & Hypotheses

The primary research questions of the proposed study relate to: 1) an examination of developmental trajectories of behavior problems of youth placed in foster care and youth who remained in-home, over time; 2) an investigation of youths' quality of relationship with caregivers, and the impact of caregiver relationships on behavior problems of youth in foster care and youth in home; 3) an investigation of youths' quality of relationship with peers, and the impact of peer relationships on behavior problems of youth in foster care and youth in home; and 4) an examination of causal relations underlying youths' relationship qualities with caregivers and peers and their behavioral problems. Specifically, the research questions and hypotheses include:

1) Trajectories of internalizing and externalizing behavior problems

(1) Do youth in foster care differ from youth in home in their internalizing behavioral adjustment over time?

Hypothesis 1.1A: Youth in foster care will display higher internalizing behavioral problems at baseline than youth in home.

Hypothesis 1.1B: The rate of change in their internalizing behavioral

problems will not significantly differ from youth in home over time. Youth in foster care will be able to build close relationships with foster caregivers and peers over time, which will mitigate their internalizing behavioral problems (as described in Hypotheses 2 and 3 below). Thus, though youth in foster care may experience higher internalizing behavioral problems than youth in home at the time of placement (as described in Hypothesis 1.1A above), the initial difference in internalizing behavioral problems between youth in foster care and those in home will not increase over time.

- (2) Do youth in foster care differ from youth in home in their externalizing behavioral adjustment over time?

Hypothesis 1.2A: Youth in foster care will display higher externalizing behavioral problems at baseline than youth in home.

Hypothesis 1.2B: The rate of change in their externalizing behavioral problems will not differ from youth in home over time. Youth in foster care will be able to build close relationships with foster caregivers and peers over time, which will mitigate their externalizing behavioral problems (as described in Hypotheses 2 and 3 below). Thus, though youth in foster care may experience higher externalizing behavioral problems than youth in home at the time of placement (as described in Hypothesis 1.2A above), the initial difference in externalizing behavioral problems between youth in foster care and those in home will not increase over time.

2) Caregiver relationships and behavior problems

- (1) Are relationships with caregivers associated with youths' internalizing behavior problems?

Hypothesis 2.1A: Youth with more positive relationships with caregivers at baseline will display less internalizing behavioral problems at baseline.

Hypothesis 2.1B: Youth with more positive relationships with caregivers at baseline will display less internalizing behavioral problems over time.

- (2) Hypothesis 2.1C: Changes in youths' relationships with caregivers will be negatively related to changes in their internalizing behavioral problems over time. That is, the more positive relationships with caregivers youth develop, the less internalizing behavior problems they will display over time. Are relationships with caregivers associated with youths' externalizing behavior problems?

Hypothesis 2.2A: Youth with more positive relationships with caregivers at baseline will display less externalizing behavioral problems at baseline.

Hypothesis 2.2B: Youth with more positive relationships with caregivers at baseline will display less to externalizing behavioral problems over time.

Hypothesis 2.2C: Changes in youths' relationships with caregivers will be negatively related to changes in their externalizing behavioral problems over time. That is, the more positive relationships with caregivers youth develop over time, the less externalizing behavior problems they will display over time.

3) Peer relationships and behavior problems

(1) Are relationships with peers associated with internalizing behavior problems?

Hypothesis 3.1A: Youth with more positive relationships with peers at baseline will display less internalizing behavioral problems at baseline.

Hypothesis 3.1B: Youth with more positive relationships with peers at baseline will display less internalizing behavioral problems over time, regardless of group status.

Hypothesis 3.1C: Changes in youths' relationships with peers will be negatively related to changes in their internalizing behavioral problems over time. That is, the more positive relationships with peers youth develop, the less internalizing behavior problems they will display over time.

(2) Are relationships with peers associated with youths' externalizing behavior problems?

Hypothesis 3.2A: Youth with more positive relationships with peers at baseline will display less externalizing behavioral problems at baseline.

Hypothesis 3.2B: Youth with more positive relationships with peers at baseline will display less externalizing behavioral problems over time.

Hypothesis 3.2C: Changes in youths' relationships with peers will be negatively related to changes in their externalizing behavioral problems over time. That is, the more positive relationships with peers youth develop, the less externalizing behavior problems they will display over time.

4) Causal relations between relationships and behavioral problems

- (1) Are causal relations between relationships and internalizing behavioral problems found?

Hypothesis 4.1A: It is hypothesized that caregiver relationships will affect youths' internalizing behavioral problems and peer relationships at subsequent wave.

Hypothesis 4.1B: It is hypothesized that peer relationship will affect youths' internalizing behavioral problems and caregiver relationships at subsequent wave.

Hypothesis 4.1C: It is hypothesized that youths' internalizing behavior problems will affect caregiver and peer relationships at subsequent wave.

- (2) Are causal relations between relationships and externalizing behavioral problems found?

Hypothesis 4.2A: It is hypothesized that caregiver relationships will affect youths' externalizing behavioral problems and peer relationships at subsequent wave.

Hypothesis 4.2B: It is hypothesized that peer relationships will affect youths' externalizing behavioral problems and caregiver relationships at subsequent wave.

Hypothesis 4.2C: It is hypothesized that youths' externalizing behavior problems will affect caregiver and peer relationships at subsequent wave.

CHAPTER 3

METHODOLOGY

This chapter describes the National Survey of Child and Adolescent Well-being (NSCAW) and the sample used in this study. Specific measures for constructs of interest and analytic strategies to evaluate each hypothesis are explained.

Data

This study used data from the National Survey of Child and Adolescent Well-being (NSCAW), a national probability sample of children and adolescents who had contact with Child Protective Services. NSCAW is the first national study to collect comprehensive data from children, caregivers, caseworkers, and teachers to examine the well-being of children who have had contact with the child welfare system. The NSCAW sample was selected by a two-stage stratified sampling design. The states were divided into nine sampling strata. Primary sampling units (PSUs) were formed based on geographic areas and randomly selected within each stratum. Within PSUs, children were randomly selected from the sampling frame of children ages 0 to 14 who had contact with the child welfare system between October 1999 and December 2000. Infants, sexual abuse cases, and cases receiving ongoing services after investigation were oversampled so that enough cases would be included to ensure adequate statistical power.

The sample includes 5,501 children from those who were investigated for child abuse or neglect by CPS during the sampling period (CPS sample), and 727 children who had been investigated for child abuse or neglect before out-of-home placement and had been in out-of-home care for approximately one year during the sampling period (longer-

term foster care sample [LTFC]). The data were collected across five waves. For the CPS sample, the baseline interviews were conducted approximately two to six months after the close of the investigation. The follow-up interviews were scheduled 12 months (Wave 2), 18 months (Wave 3), 36 months (Wave 4), and 48 months (Wave 5) after the close of the investigation. For the LTFC sample, the follow-ups were scheduled approximately 24 (Wave 2), 30 (Wave 3), and 48 months (Wave 4) after the child was placed in out-of-home care. The CPS sample included both cases that received on-going services and those not receiving case, either because they were not substantiated or because it was determined that services were not required (for more information regarding the study design and sampling method, see Dowd et al., 2007).

Sample

The present study focused on the CPS sample of youths aged 11 or older at baseline and examined what happened to them over time in relation to changes in externalizing and internalizing behavioral problems. The study used the data collected at Waves 1, 3, and 4. Data from Wave 2 were not used in the present study because direct interviews with youth were not conducted. The initial sample of youth ages 11 and older was 1,178 at baseline (352 in foster care, 826 at home). One of the key interests of this study is to examine if youth show different developmental trajectories by placement status. Thus, children were excluded from the final sample if they had missing data for (a) out-of-home placement status at any of the three time points or (b) proportion of days in out-of-home placement across the three time points. The sample was reduced to 950 (80.6 %) due to missing data and attrition. To examine possible bias, the final sample ($n = 950$) and the excluded cases ($n = 229$) were compared on the main variables (baseline

CBCL scores, caregiver relationships, and peer relationships) and demographic variables (child age, gender, race/ethnicity). The two groups were not significantly different on these variables.

Placement groups.

In order to investigate if children had different developmental trajectories depending on whether they stayed at home or were placed in out-of-home care after the initial CPS investigation, the sample was divided into four placement groups. In her dissertation using NSCAW baseline and 18-month data, Wall (2004) categorized the CPS sample into three groups: in-home (children who lived at home at baseline and 18 months and lived in out-of-home care for less than 5% of the 18-month period), out-of-home (children who lived in out-of-home care at baseline and 18 months and lived in out-of-home care for greater than 95% of the 18-month period), and mixed type (children who lived in the home at both waves but spent less than 95% of time in out-of-home care, children who lived at home at baseline and out-of-home at 18 months, and children who lived in out-of-home care at baseline and at home at 18 months).

In the present study, mixed type was further divided into two groups: (a) youths who were placed in out-of-home care at baseline but were reunified with the biological family in any of the subsequent waves and (b) youths who were in the home at baseline but were not living at home in any of the subsequent waves. Specifically, based on Wall's categorization, the final sample in the present study were grouped into out-of-home (OOH: living in nonkinship foster care, kinship foster care, group care, or other out-of-home placement at baseline, 18 months, and 36 months, and lived in out-of-home care for greater than 95% of 36-month period; hereinafter Group 1), in-home (living in the home

at baseline, 18 months, and 36 months, and lived in out-of-home care for less than 5% of the 36-month period; hereinafter Group 2), out-of-home mixed (youth living in out-of-home care at baseline but returned home at 18 or 36 months, youth who lived in out-of-home care at all three waves but spent less than 95% of 36 month period in out-of-home care, and youth who lived in out-of-home at baseline and returned home at 18 months but placed in out-of-home again at 36 months; hereinafter Group 3), and in-home mixed (youth who lived at home at baseline but were placed in out-of-home care at 18 or 36 months; youth who lived at home at all three waves but spent more than 5% of time in out-of-home care; and youth who lived at home at baseline, were placed out of the home at 18 months, but returned home again at 36 months; hereinafter Group 4).

Measures

Internalizing and externalizing behavior problems.

Youths' internalizing and externalizing behavior problems were measured by the Child Behavior Checklist 4-18 (CBCL) (Achenbach, 1991). The CBCL 4-18 is standardized set of measures for assessing children between the ages of 4 and 18 from parent-, teacher-, and self-reports. Caregivers completed the CBCL, teachers completed the Teacher Report Form (TRF), and youths completed the Youth-Self Report Form (YSR).

The CBCL, TRF, and YSR consist of eight narrow band scales: Social Withdrawal, Somatic Complaints, Anxiety/Depression, Social Problems, Thought Problems, Attention Problems, Delinquent Behavior, and Aggressive Behavior. In addition to these eight scales, the CBCL includes the scale of Sex Problems, and the YSR

includes Self-Destructive Behavior. All three instruments contain two broad-band groupings of narrow-band syndromes: internalizing problems and externalizing problems. Internalizing problems combines three narrow-band syndromes (social withdrawal, somatic complaints and anxiety/depression), whereas externalizing problems combines two narrow-band syndromes (delinquent behavior and aggressive behavior).

In this study, the internalizing and externalizing raw scores provided by youth were used to measure internalizing and externalizing behavior problems. Youth self reports were used in this study because different caregivers or teachers may have been interviewed over time, which could have influenced the results. In addition, caregivers and teachers may have limited knowledge of the children's behavior, especially internalizing behavior problems. Raw scores can be converted to T scores (mean = 50, $SD = 10$), which are standardized by age and gender. For internalizing, externalizing, and total problem behaviors, T scores above 63 are considered in the clinical range, from 60 to 63 are considered borderline scores, and less than 60 are considered normal. Though T scores have the advantage of allowing for comparisons with normative samples of children within the same age range, they obscure age and gender differences that may be of interest. Second, the use of age-group norms can be problematic in longitudinal studies as children age from one set of norms into another (Rosenthal & Curiel, 2006). Higher raw scores indicate more behavior problems. Internal consistency reliabilities in the present study were .89 for internalizing and externalizing behavior problems.

Relationship with caregivers.

The relationship with caregivers was assessed using the shortened version of the Relatedness Scale from the Rochester Assessment Package for Schools (RAPS; Connell,

1990; Lynch & Cicchetti, 1991), which was completed by the youths. The shortened version comprises two sets of 12 items (24 items in total) that assess children's relationships with their primary and secondary caregivers. The measure contains four subscales: parental emotional security (child feels good, mad, or happy with the caregiver), involvement (caregiver enjoys, or spends time with the child, helps the child, and knows how the child feels), autonomy support (caregiver supports, or allows the child make decision), and structure (caregiver treats the child fairly, trusts the child's abilities, and the child understands what the caregiver wants). Responses were scored from 1 (*not at all true*) to 4 (*very true*). The mean of 12 items that assess children's relationships with their primary caregivers was computed to measure the caregiver-youth relationship. A higher score indicates a more positive caregiver relationship. The internal consistency reliability for the sample was .81.

Relationship with peers.

The Loneliness and Social Dissatisfaction Questionnaire (Asher & Wheeler, 1985), which was completed by the youths, was used to assess their peer relationships. The measure consists of 16 items dealing with the making and keeping of friends at school and also with feelings of loneliness. The responses ranged from 1 (*never*) to 5 (*always*). Several items were reverse-coded so that a higher score reflected more loneliness. The sum of the 16 items from this measure was used. A higher total score on this measure indicated a greater level of loneliness and more negative peer relationships. The internal consistency reliability for the sample was .90.

Analytic Strategies

To investigate the hypotheses, two types of structural equation modeling (SEM), latent growth curve modeling and cross-lagged designs were conducted using M-Plus 5.1 with a maximum likelihood estimation method (ML) (Muthen & Muthen, 2008). Latent growth curve modeling, which allows for the investigation of longitudinal trajectories, were conducted to evaluate Hypotheses 1-3. To evaluate hypothesis four which assesses temporal causal orders among variables, autoregressive cross-lagged design (ARCL) was used.

Given NSCAW is complex survey data, the options for clustering, stratification, and sampling weights were included for all analyses. An MLR estimator (maximum likelihood estimation with robust standard errors) is used for complex data in M-Plus. When skewness tests for normality were conducted for the main variables, the scores for CBCL internalizing and externalizing behavior problems, caregiver relationships, and peer relationships had significantly nonnormal skewness. The MLR estimator used for complex data was robust to the nonnormality of the data (Muthen & Muthen, 2008), and thus, a nonlinear transformation to make the skewed distributions more normal was not employed for these variables. The specific analytic procedures are explained below in detail.

Trajectories of behavior problems and the relationship qualities.

Baseline growth curve model.

Latent growth curve modeling is the preferred way to analyze changes in a behavior when one has panel data, where cases are observed repeatedly over multiple

time points (Curran, Harford, & Muthen, 1996).

A linear pattern over time was assumed as just three periods of data were used to estimate the trajectory model. The baseline growth model was a two-factor growth model with three time points (see Figure 1). The first latent factor (α) indicates the intercept (or the initial level) of the growth curve. This represents the starting point of the growth curve (or the magnitude of behavior problems) at baseline. The second latent factor (β) indicates the slope of the growth curve and represents the rate of change over time. The level 1 equation is as follows:

$$y_{it} = \alpha_i + \beta_i t + \varepsilon_{it}$$

y_{it} is the value of trajectory variable y for the i th case at time t , α_i is the intercept for case i , β is the slope for case i , and ε is the measurement error. Each y_{it} is an observed measure of the behavior problems of individual i at time t . This equation represents within-individual (i) change over time (t).

The second level of the growth model represents between-individual change over time. The random intercepts (α_i) and slopes (β_i) are a function of variables that change across individuals (i) but do not change across time (t). The level two equations are as follows:

$$\alpha_i = \alpha_0 + \alpha_1 x_{i1} + \alpha_2 x_{i2} + \dots + \alpha_k x_{ik} + u_i$$

$$\beta_i = \beta_0 + \beta_1 x_{i1} + \beta_2 x_{i2} + \dots + \beta_k x_{ik} + v_i$$

Because the linear growth curves tested for three equally spaced repeated measures (i.e., baseline, 18 months, and 36 months) in the current study, slope factor loadings were set at 0, 1, and 2 for Time 1, 2, and 3, respectively. The intercept factor

loadings of the repeated measures were set to 1.0. Two latent factors (i.e., the intercept and slope) were allowed to correlate. The means of two latent factors represent the mean initial level and rate of change of the overall group growth curve. The variances of two latent factors represent individual variability in the initial level and rate of change. The means of the latent factors are considered to be the fixed component, and the variances of latent factors are considered to be the random component (Bollen & Curran, 2006).

Model fit was evaluated using the maximum likelihood ratio test statistic (χ^2) and three supplemental measures of model fit: the root mean square error of approximation (RMSEA), the Comparative Fit Index (CFI), and the Tucker-Lewis Index (TLI). χ^2 , if significant, indicates poor fit. An RMSEA range below .05 and a CFI or TLI value close to 1.0 indicate a very good fit. A value of 0.90 or greater for CFI or TLI and a value of 0.10 or less for RMSEA are considered moderate or acceptable (Bollen & Curran, 2006).

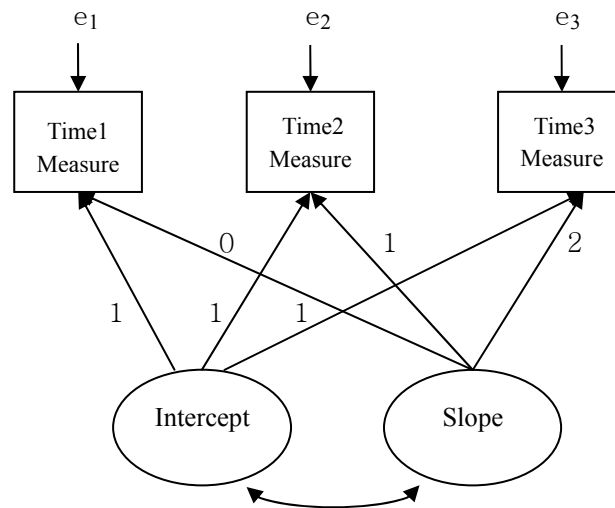

Figure 1. Baseline Latent Growth Curve Model.

Testing group differences.

Multigroup analyses were used to test if initial levels and rates of changes in internalizing and externalizing behavior problems varied across placement groups (Hypothesis 1). The baseline growth models depicted in Figure 1 were re-estimated using multigroup modeling with the four groups. First, all parameters were freely estimated across the four groups (no constraint model). Then, equality constraints were imposed hierarchically. At first, the intercept and slope means were constrained equally. In instances where the equality constraint on growth factor means model were retained, equality constraints on growth factor variances and covariance were further imposed. Chi-square difference tests¹ were estimated to test the adequacy of the constraints relative to the less constrained models (Bollen & Curran, 2006). Separate growth models were estimated for internalizing problems and externalizing problems. In addition, multigroup analyses were estimated for caregiver relationships and peer relationships in order to examine if youth developed different relationship trajectories over time by their placement status.

Effects of caregiver relationships and peer relationships.

The relationship between youths' relationship qualities and behavior problems was evaluated using multivariate latent growth curve models (Hypotheses 2 & 3). The two baseline growth models described earlier were estimated simultaneously (see Figure 2). To examine the influence of the initial levels of relationship quality, the intercepts and slopes of youths' behavior problems were regressed on the intercepts of the different

¹ The chi-square value for MLR in M-Plus is a scaled chi-square, where the normal chi-square is divided by a scaling correction factor to approximate the chi-square under nonnormality. An MLR chi-square cannot be used for chi-square difference tests, and chi-square differences were computed using MLR chi-square and a scaling correction factor.

types of relationship quality. To explore how rates of change in relationship quality predicted rates of change in behavior problems over time, the slopes of the behavior problems were regressed on the slope of relationship quality. The growth factors of each construct were allowed to covary.

The adequacy of the contemporaneous residual covariances between the two constructs was tested using a chi-square difference test. First, the model was conducted without contemporaneous residual covariances (e.g., Time 1 caregiver relationship residual with Time 1 internalizing behavior problems). Then, the residuals of the repeated measures were correlated within all three time points between the two constructs. These

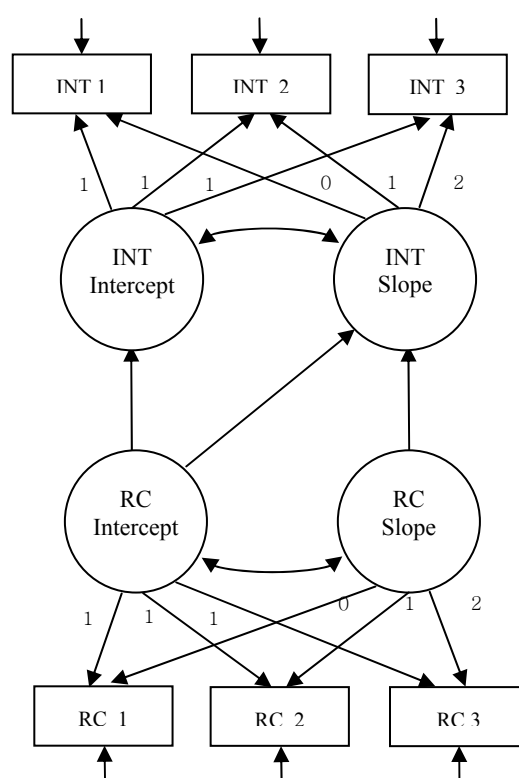

Figure 2. Latent growth model: The impact of caregiver relationship on internalizing behavior problems. *Note.* INT: Internalizing behavior problems, RC: Relationship with caregivers.

correlations represent shared variability between two constructs within time period. The present study has two relationship quality variables that serve as predictors (caregiver and peer relationships) and two dependent variables that serve as outcome variables (internalizing and externalizing behavior problems). To investigate the unique influence of each predictor on each outcome, separate analyses were conducted.

Casual relations between relationships and behavioral problems

Autoregressive cross-lagged design.

To assess temporal causal links between caregiver and peer relationships and behavioral problems (Hypothesis 4), ARCL tests were used. In an ARCL model, autoregressive paths link a variable measured earlier with the same variable measured later (e.g., Time 1 behavior problems predict Time 2 behavior problems) and estimate relative stability of the construct over time. Cross-lagged regressions estimated the paths between constructs (e.g., Time 1 caregiver relationships predicted Time 2 behavior problems). Significant cross-lagged paths indicate that one construct is a temporal predictor of the other. Figure 3 presents a cross-lagged model with two variables measured at three time points. In bivariate auto-regressive cross-lagged model, variable y at time t is a combined function of y at time $t-1$, w at time $t-1$, and a time-specific residual (Bollen & Curran, 2006).

$$y_{it} = \alpha_{yt} + \rho_{y|y,t-1} y_{i,t-1} + \rho_{y|w,t-1} w_{i,t-1} + \varepsilon_{it}$$

$$w_{it} = \alpha_{wt} + \rho_{w|y,t-1} y_{i,t-1} + \rho_{w|w,t-1} w_{i,t-1} + \varepsilon_{it}$$

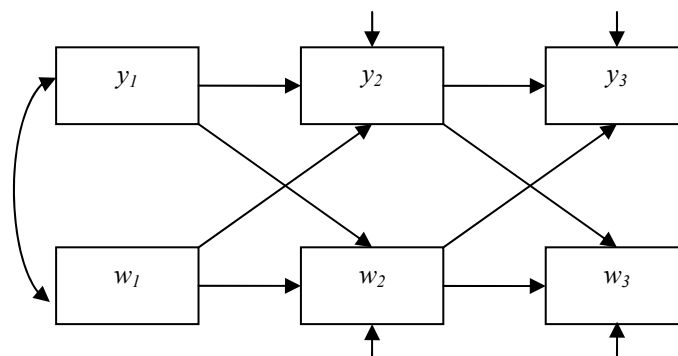

Figure 3. Path diagram of bivariate autoregressive cross-lagged model.

Generally a set of hypothesized models is evaluated systematically in a cross-lagged design. For a cross-lagged design with two variables, four hypothesized models are tested: (a) a baseline model with only the autoregressive effects, (b) a model with the autoregressive effect and “down” cross lagged paths (i.e., one variable predicting the other at later time points), (c) a model with the autoregressive effect and “up” cross lagged paths (the other variable predicting the former at later time points), and (d) a fully cross-lagged model with the autoregressive effects and both up and down paths (Martens & Haase, 2006). In ARCL, it is generally assumed that the baseline variables are correlated with each other (e.g., Time 1 caregiver relationships and Time 1 behavior problems) and that disturbance terms are correlated with each other at later time points (e.g., Time 2 disturbance is associated with caregiver relationships and Time 2 disturbance is associated with behavior problems). The disturbance terms indicate the amount of variability associated with unknown factors and thus unexplained by variables in the model (Martens & Haase, 2006).

In this study, an ARCL model for three constructs over three time points was used to examine the relationships among three variables. A series of models was tested (see

Figure 4). The baseline model (Model 1) included only the autoregressive effects measuring the stability within each construct. Time 1 variables and the disturbance terms at Time 2 and Time 3 were correlated. The addition of correlated disturbances within time significantly improved the model fit. Model 1 assumed that three constructs (i.e., youths' relationships with caregivers and peers and youths' behavior problems) were highly stable over time and that there were no cross-lagged relationships between the three variables. Next, caregiver relationships were hypothesized as the predictor of peer relationships and behavior problems at subsequent time points (Model 2). The prospective cross-lagged paths were added in which peer relationships and behavior problems were regressed on the previous measure of caregiver relationships (e.g., Time 1 caregiver relationship predicted Time 2 peer relationships and behavior problems). Model 2 assumed that caregiver relationships contributed causally to changes in peer relationships and behavior problems at subsequent time points. Model 3 assumed that peer relationships predicted later caregiver relationships and behavior problems. Caregiver relationships and behavior problems were regressed on the previous measure of peer relationships. Model 4 hypothesized behavior problems as the predictor of caregiver relationships and peer relationships. Caregiver relationships and peer relationships were regressed on the previous measure of behavior problems. Finally, it was hypothesized that there were causal relationships between all three variables (Model 5). The reciprocal model is a full cross-lagged model in which each variable was assumed to predict the other two variables at subsequent time points. To compare models, chi-square difference tests were conducted, in which the chi-squares of nested models were compared to determine which one provided a significantly better fit. Based on these

model tests, the best fitting parsimonious model was selected. A separate set of analyses was conducted for internalizing and externalizing behavior problems.

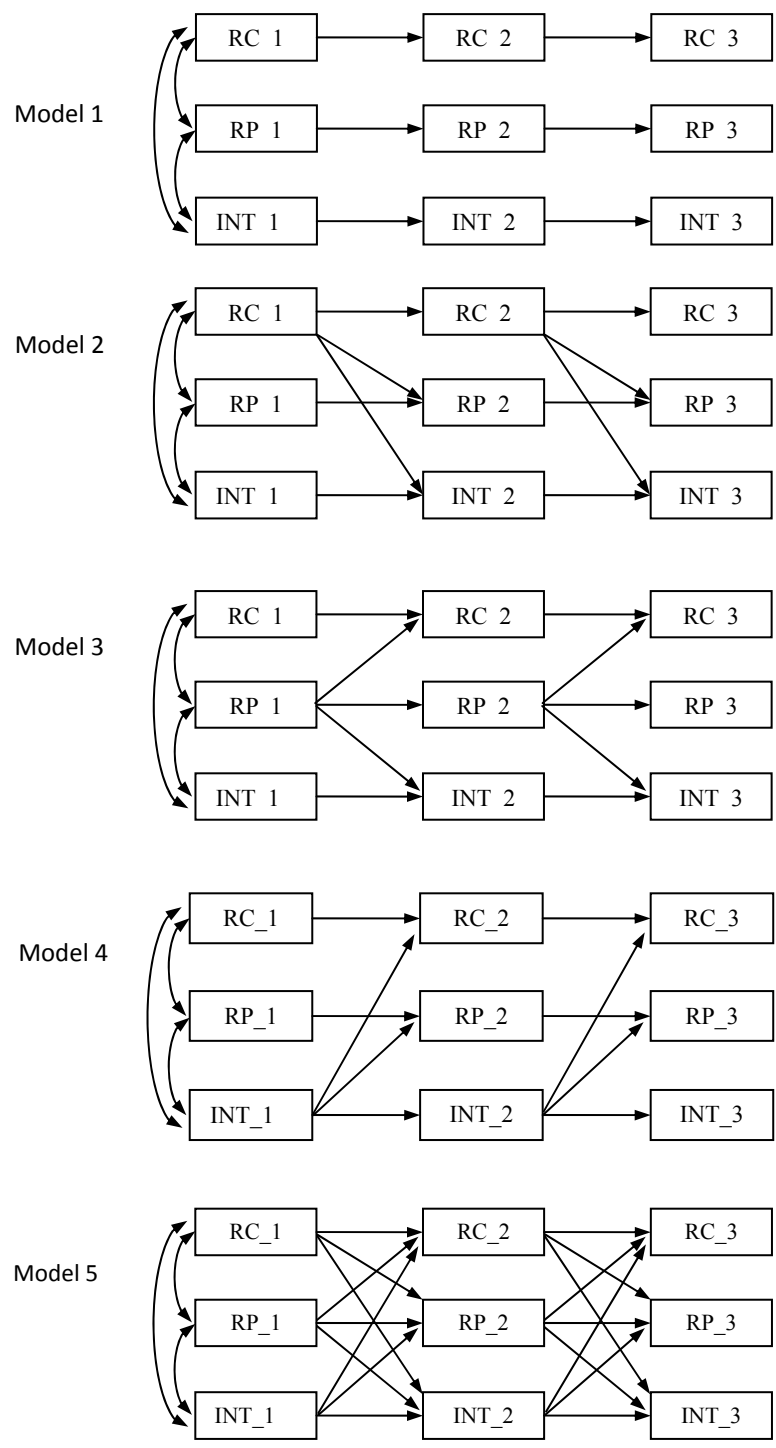

Figure 4. Hypothesized cross-lagged models of caregiver relationships, peer relationships, and internalizing behaviors. Note. RC: caregiver relationships, RP: peer relationships, INT: internalizing behavior problems; within-time residual correlations are estimated but omitted for simplicity of representation

CHAPTER 4

RESULTS

Sample Description

Table 1 presents weighted descriptive statistics for the whole sample and by placement group. Groups 1 and 2 represent OOH youth and in-home youth, respectively. Group 3 represents youth who were placed in OOH initially and then returned home later. Group 4 includes those who remained at home initially and were placed in OOH later. Group 1 made up 10.4% of the unweighted sample ($n = 99$), Group 2 made up about half of the sample (47.9%, $n = 455$), Group 3 made up 20.4% ($n = 194$), and Group 4 made up 21.3% ($n = 202$). The numbers for the weighted sample were 4.2%, 65.5%, 11.6%, and 18.7%, respectively.

Children in the final sample averaged 12.7 years of age, and 42.2% were male. Approximately half were White (48.4%), followed by Black (30.0%) and Hispanic (15.4 %). Neglect was the most serious type of maltreatment reported for nearly half of the sample (44.5%), followed by physical abuse (31.4%), sexual abuse (12.8%), and emotional abuse (8.4%). At baseline, 84% of children remained at home, whereas 16% were placed in out-of-home care. About one third of children in out-of-home care were placed in kin care (31.9%), 24.3% in nonkin foster care, 22.6% in group or residential care, and 21.2% in other out-of-home care. On average, youth in the final sample spent 19% of the 36-month period in out-of-home care.

Table 1
Sample Description

	Total (weighted % or Mean[SE])	Group 1 (weighted % or Mean[SE])	Group 2 (weighted % or Mean[SE])	Group 3 (weighted % or Mean[SE])	Group 4 (weighted % or Mean[SE])
Age	12.67 (0.07)	13.02 (0.26)	12.60 (0.09)	12.77 (0.16)	12.75 (0.16)
Child gender					
Male	42.2	40.2	41.6	51.1	39.5
Female	57.8	59.8	58.4	48.9	60.5
Race/ethnicity					
Black	30.0	55.5	25.2	36.0	37.7
White	48.4	24.6	50.4	51.3	45.2
Hispanic	15.4	14.4	17.4	7.2	13.7
Other	6.1	5.5	7.0	5.5	3.3
Type of Abuse					
Physical	31.4	12.1	34.2	25.1	28.1
Sexual	12.8	15.8	11.9	16.3	13.5
Emotional	8.4	17.6	8.5	8.3	6.9
Neglect	44.5	49.0	41.8	49.3	50.7
Others	2.8	5.4	3.5	1.1	0.7
Placement at W1					
In-home	84.2	-	100.0	-	100.0
OOH	15.8	100.0	-	100.0	-
Foster	24.3	31.7	-	21.6	-
Kin care	31.9	19.5	-	36.4	-
Group/res	22.6	25.3	-	21.7	-
Other	21.2	23.5	-	20.4	-
Length in OOH	0.19 (0.02)	0.99 (0.00)	0.00 (0.00)	0.51 (0.05)	0.46 (0.05)

Note. Group 1: OOH youth, Group 2: in-home youth, Group 3: initial OOH youth, Group 4: initial in-home youth.

Group means for the CBCL, caregiver relationships, and peer relationships are presented in Table 2. It appears that internalizing behavior problems and negative peer relationships decreased slightly over time.

Table 2

Means of CBCL, Caregiver Relationships, and Peer Relationships by Placement Group

	Total	Group 1	Group 2	Group 3	Group 4
Internalizing problems					
Time 1	12.95	13.73	12.11	14.92	14.50
Time 2	10.98	11.22	10.48	11.45	12.33
Time 3	9.79	11.21	9.22	11.06	11.17
Externalizing problems					
Time 1	14.03	13.03	13.37	15.37	15.76
Time 2	14.35	13.60	13.74	15.40	16.01
Time 3	14.09	11.92	13.73	14.90	15.39
Caregiver relationships					
Time 1	3.30	3.34	3.34	3.17	3.21
Time 2	3.35	3.41	3.42	3.32	3.10
Time 3	3.33	3.50	3.37	3.21	3.24
Peer relationships					
Time 1	30.74	29.83	30.17	33.60	31.32
Time 2	28.02	31.41	27.85	26.50	28.86
Time 3	27.05	28.70	26.97	26.98	26.99

Note. Group 1: OOH youth, Group 2: in-home youth, Group 3: initial OOH youth, Group 4: initial in-home youth.

Trajectories of Youths' Behavior Problems and Relationships with Caregivers and Peers

Examining Growth Over Time: Unconditional Models

Prior to testing group differences (Hypothesis 1), baseline growth curve models were conducted to test for the presence of linear change over the 36-month period.

Unconditional baseline models were conducted separately for internalizing problems, externalizing problems, caregiver relationships, and peer relationships.

Internalizing behavior problems.

A two-factor linear growth curve model was estimated for internalizing behavior problems, and the linear model provided an excellent fit to the data. Model fitting indices produced a nonsignificant chi-square value of 0.67, a CFI of 1.00, a TLI of 1.00, and an RMSEA of 0.00 (see Table 3). The equality of the error variances across the three time points was tested first. The baseline model was run without an equality constraint on the error variances and then with the equality constraint imposed. A nested chi-square difference test was used, and the chi-square difference was significant ($\Delta\chi^2 = 8.33$, $\Delta df = 2$, $p < .05$). This indicates that the equality constraint significantly degraded the model fit, and thus the equality of error variances was rejected. The errors varied across the three time points.

Figure 5 presents the parameter estimates of the growth model for internalizing behavior problems. The mean initial level of the internalizing behavior growth curve was 12.81 ($SE = .83$, $p < .001$). The mean rate of change of the internalizing behavior growth curve was -1.53 ($SE = .33$, $p < .001$), indicating that, on average, youths' internalizing behavior problems decreased by 1.53 points every 18 months. There were significant individual differences both in the initial level of internalizing behavior problems ($\sigma^2 = 80.56$, $SE = 19.08$, $p < .001$) and in the rate of change of those problems over time ($\sigma^2 = 16.22$, $SE = 5.13$, $p < .01$). The intercept and slope were negatively correlated ($r = -.69$, $SE = .09$, $p < .01$). This indicates that youth with higher initial levels of internalizing problems tended to show a sharper decrease in internalizing behavior problems over time compared with those who reported lower initial levels of internalizing behavior problems.

Externalizing behavior problems.

A linear growth model was estimated for externalizing behavior problems. Similar to the internalizing-behavior-problems model, the equality of the error variances was tested. The chi-square difference test was not significant ($\Delta\chi^2 = .96$, $\Delta df = 2$). This indicates that the equality constraint did not significantly degrade model fit and, thus, the equality of error variances was retained for parsimony. The linear growth model provided an excellent fit for externalizing behavior problems ($\chi^2 = 1.34$, *ns*, CFI = 1.00, TLI = 1.00, RMSEA = 0.00). The growth model for the externalizing behavior problems is depicted in Figure 5. The mean initial level of externalizing behavior problems was 14.12 ($SE = .68$, $p < .001$). The slope mean was positive, but it was not significantly different from zero ($M = 0.03$, $SE = .28$), indicating that youths' externalizing behavior problems did not change significantly over time. However, there were significant individual differences in the initial levels ($\sigma^2 = 63.40$, $SE = 9.21$, $p < .001$) and the rates of change ($\sigma^2 = 5.72$, $SE = 2.04$, $p < .01$) in externalizing behavior problems. A significant correlation between the intercept and slope factors implies that there was a negative association between the initial level of externalizing behavior problems and the rate of change over time ($r = -.45$, $SE = .10$, $p < .01$).

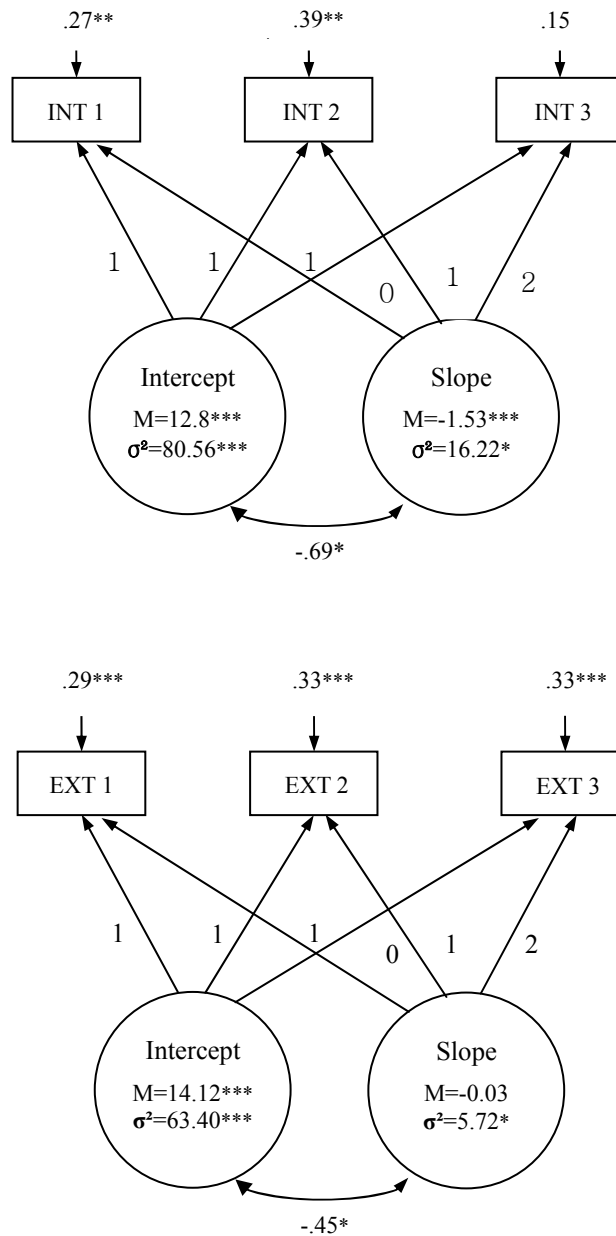

Figure 5. Baseline growth curve models for internalizing and externalizing behavior problems. *Note.* INT = internalizing behavior problems, EXT = externalizing behavior problems; M = mean, σ^2 = variance; the factor means and variances are in raw metric; the factor correlation and the error variances of the repeated measures are in standardized metric; all factor loadings were set to predetermined values and thus not estimated; $*p < .05$. $**p < .01$. $***p < .001$.

Table 3
Model Indices for Baseline Growth Curve Models

	χ^2	<i>p</i>	CFI	TLI	RMSEA
Internalizing behavior problems	0.67	.41	1.00	1.00	.00
Externalizing behavior problems	1.34	.71	1.00	1.00	.00
Caregiver relationship	2.97	.40	1.00	1.00	.00
Peer relationship	5.05	.17	0.99	0.99	.03

Caregiver relationships.

A linear model was estimated for youths' relationships with caregivers. When error variances were constrained to be equal across the three time points, as with externalizing behavior problems, the model fit was not significantly worse ($\Delta\chi^2 = 1.87$, $\Delta df = 2$, *ns*). Therefore, the equal error variances were retained. The fit of the linear growth model was excellent ($\chi^2 = 2.97$, *ns*, CFI = 1.00, TLI = 1.00, RMSEA = 0.00). Figure 6 presents the parameter estimates of the growth model for caregiver relationships. The mean of the intercept was 3.31 ($SE = .05$, $p < .001$). The mean of the slope ($M = 0.02$, $SE = .02$, *ns*) was positive but not significantly different from zero, indicating that children's caregiver relationships did not change significantly over time. Significant variance was found in both the intercept ($\sigma^2 = 0.20$, $SE = .04$, $p < .001$) and the slope ($\sigma^2 = 0.03$, $SE = .01$, $p < .001$). This indicated that there were significant individual differences in the initial levels and rates of change in youths' caregiver relationships. The intercept and slope were negatively correlated with each other ($r = -.65$, $SE = .10$, $p < .001$). As the initial level of relationship with caregiver increased, the rate of change in the relationship with the caregiver decreased.

Peer relationships.

A linear model was estimated for youths' relationships with peers. A chi-square difference test indicated that errors did not vary significantly over time ($\Delta\chi^2 = 2.97$, $\Delta df = 2$), and thus the error variances were held equal across all time points. The linear growth model fit the data very well ($\chi^2 = 5.05$, *ns*, CFI = 0.99, TLI = 0.99, RMSEA = 0.03). The growth model for peer relationships is presented in Figure 6. The initial level of peer relationships was 30.47 ($SE = .83$, $p < .001$). The mean of the slope was significantly negative ($M = -1.87$, $SE = .34$, $p < .001$), indicating that youths' negative peer relationships decreased over time by -1.87 points per 18-month period. Significant individual variability existed in both the initial levels ($\sigma^2 = 99.82$, $SE = 20.84$, $p < .001$) and rates of change ($\sigma^2 = 10.64$, $SE = 4.91$, $p < .05$) in youths' peer relationships. The two factors were negatively correlated ($r = -.71$, $SE = .07$, $p < .01$). Youths with higher initial levels of negative peer relationships tended to display sharper decreases in negative peer relationships over time compared with youths who reported lower initial levels of negative peer relationships.

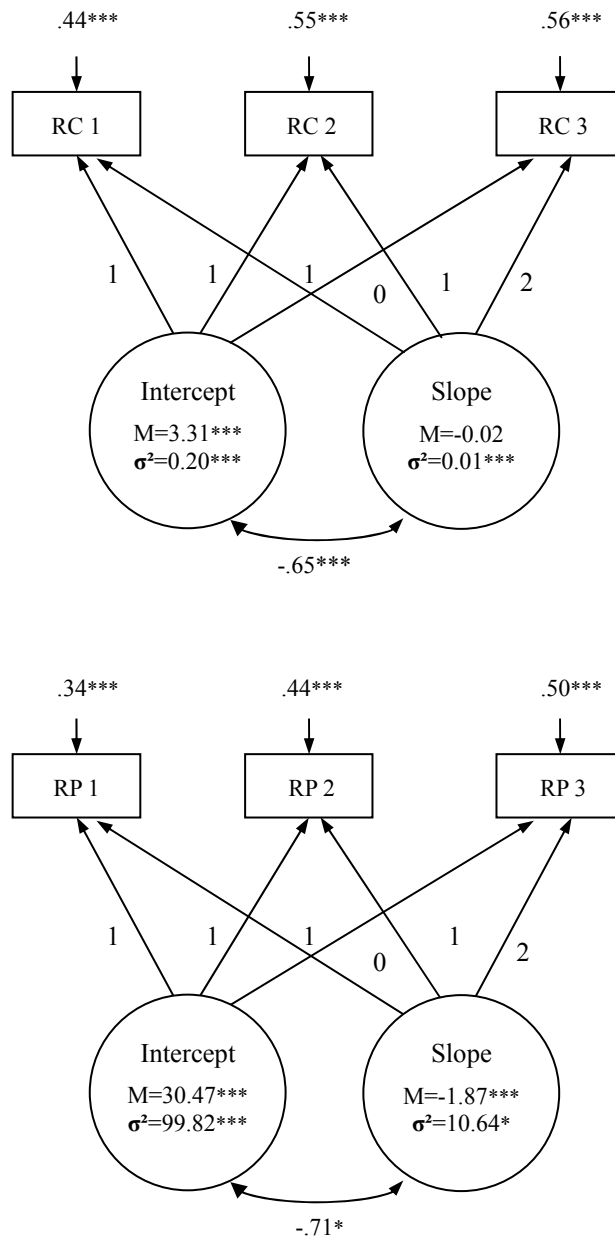

Figure 6. Baseline growth curve models for caregiver and peer relationships. *Note.* RC = relationship with caregivers, RP = relationship with peers; M = mean, σ^2 = variance; the factor means and variances are in raw metric units; the factor correlation and the error variances of the repeated measures are in standardized metric units; all factor loadings were set to predetermined values and thus not estimated; * $p < .05$. ** $p < .01$. *** $p < .001$.

Results summary of unconditional models.

Unconditional models were conducted separately for youths' internalizing behavior problems, externalizing behavior problems, relationship with caregivers, and relationship with peers to examine whether linear growth curves were present in each of these variables. The results indicated that the linear model fit the data very well for all four variables. Negative linear change was found in youths' internalizing behavior problems and negative peer relationships. Youths' internalizing behavior problems were likely to decrease by -1.53 points in the period of 18 months ($SE = .33, p < .001$). Youths' negative peer relationships tended to decrease by -1.87 points every 18 months ($SE = .34, p < .001$); in other words, youths' relationships with peers were likely to improve over time. On the other hand, no significant change was observed in youths' externalizing behavior problems (slope mean = 0.03, $SE = .28$) or their relationships with caregivers (slope mean = 0.02, $SE = .02, ns$), indicating that youths' externalizing behavior problems and caregiver relationships tended to remain stable over time.

Testing Group Differences: Multigroup Analyses

To examine the first set of research questions about group differences in youths' behavior problems, it was hypothesized that though youths in foster care would experience higher internalizing and externalizing behavior problems at baseline than youths remaining at home (Hypotheses 1.1A and 1.2A, respectively) and that the rates of change in internalizing and externalizing behavior problems would not significantly differ among groups over time (Hypotheses 1.1B and 1.2B, respectively).

Internalizing behavior problems.

The model test results are presented in Table 4. The baseline model (no constraint) fit was excellent ($\chi^2 = 2.54$, *ns*, CFI = 1.00, TLI = 1.00, RMSEA = 0.00). Error variances were not assumed to be equal across time points as described earlier. First, the means of the intercepts and the slopes were constrained to be equal across the four groups. The equality constraint on the growth factor means did not degrade the model fit and was therefore retained ($\Delta\chi^2 = 5.99$, $\Delta df = 6$, *ns*). Next, the variances and covariances of the growth factors were constrained to be equal across all four groups. The fit of the model with equal variances and covariances was significantly worse than the fit of the equal growth factor means model ($\Delta\chi^2 = 54.76$, $\Delta df = 11$, $p < 0.001$). Thus, the equality constraint imposed on the variances and covariances was rejected. The findings indicated that the initial levels and rates of change over time were equal across the four groups. However, the factor variances and covariances were not equal across groups. Table 5 presents the variances and covariances by placement groups. Youth remaining at home (Group 2) were characterized by significantly less variability both in the intercepts and in the slopes ($\sigma^2 = 55.33$, $SE = 12.23$, $p < .001$) compared to the youths in the other three groups. On the other hand, the youths in Group 3 (those who were placed in OOH initially and then returned home later) showed notably greater individual variability in their intercepts and slopes ($\sigma^2 = 166.88$, $SE = 76.79$, $p < .05$). Also, a factor correlation was found to be significantly greater in Group 3 compared to the other groups.

In sum, although the four placement groups were comparable in the overall initial levels and rates of change in their internalizing behavior problems, there were significant differences with regard to the variability in the initial levels and rates of the slopes.

Youths who remained continuously at home (Group 2) showed the least individual variability around group means in the initial level and rate of change of internalizing behavior problems. Youths who were placed in out-of-home care and then reunified with the family (Group 3) reported great individual variability. The results did not support Hypothesis 1.1A, which posited that “youths in foster care would display higher internalizing behavioral problems at baseline than youths at home.” However, the results did support Hypothesis 1.1B, which posited that “the rate of change in their internalizing behavioral problems would not significantly differ from youths at home over time.”

Externalizing behavior problems.

A multigroup analysis was conducted for externalizing behavior problems. The results are presented in Table 4. The constraint on the error variance did not degrade the model fit and was therefore retained. The fit of the baseline model (no-constraint model) was excellent ($\chi^2 = 7.56$, *ns*, CFI = 1.00, TLI = 1.00, RMSEA = 0.00). As described earlier, the means of the two growth factors were kept equal, and nested chi-square tests were computed to determine the differences relative to the baseline model. An equal growth factor means model did not degrade the model's fit and retained the values $\Delta\chi^2 = 6.18$, $\Delta df = 6$, *ns*. Furthermore, constraining the growth factor variance and covariance did not degrade the model fit compared to the equal growth factor means model, and thus was retained as well ($\Delta\chi^2 = 11.44$, $\Delta df = 9$, *ns*). The results indicated that both the means and the individual variability in the initial levels and rates of change in externalizing behavior problems were comparable across the four groups. The results did not support Hypothesis 1.2A, which stated that “youths in foster care would display higher internalizing behavioral problems at baseline than youths at home.” However, the results

did support Hypothesis 1.2B, which stated the “the rate of change in their internalizing behavioral problems would not significantly differ from youths at home over time.”

Table 4

Multigroup Tests for Internalizing and Externalizing Behavior Problems

	χ^2	<i>df</i>	<i>p</i>	CFI	TLI	RMSEA	$\Delta\chi^2$	Δdf	<i>p(d)</i>
<u>Internalizing behavior problems</u>									
No constraint	2.54	6	.86	1.00	1.02	.00			
Equal factor means	7.69	12	.81	1.00	1.00	.00	5.99	6	<i>ns</i>
Equal factor variances and covariance	49.80	23	.00	0.88	0.94	.07	54.76	11	< .001
<u>Externalizing behavior problems</u>									
No constraint	7.56	12	.82	1.00	1.02	.00			
Equal factor means	13.54	18	.76	1.00	1.01	.00	6.18	6	<i>ns</i>
Equal factor variances and covariance	24.52	27	.60	1.00	1.01	.00	11.44	9	<i>ns</i>

Table 5

Factor Variances and Covariance by Placement Groups

	Group 1	Group 2	Group 3	Group 4
<u>Internalizing behavior problems</u>				
Variance in Intercept	105.42**	55.33***	166.88*	97.02*
Variance in Slope	20.09*	5.12	52.21*	23.19***
Factor correlation	-.77***	-.56***	-.90***	-0.62***

Note. Group 1: OOH youth, Group 2: in-home youth, Group 3: initial OOH youth, Group 4: initial in-home youth.

Caregiver relationships.

Next, the multigroup analysis was run for caregiver relationships. Table 6 presents the results. Constraining the error variances did not degrade the model fit, and therefore the constraint was retained. Chi-square difference tests indicated that the growth factor means were equal across four groups ($\Delta\chi^2 = 10.72$, $\Delta df = 6$, *ns*). The model with equal variances and covariance worsened the model fit and thus was not retained ($\Delta\chi^2 = 34.04$, $\Delta df = 7$, $p < .001$). The results indicated that four groups were comparable in their initial levels and rates of change over time, but significant differences existed with regard to variability. Youth who remained at home at baseline (i.e., Groups 2 and 4) displayed significantly greater individual variability in their initial levels and rates of change of caregiver relationships compared to those placed in out-of-home care at baseline (i.e., Groups 1 and 3) (see Table 7).

Peer relationships.

The results of the multigroup analyses for peer relationships are presented in Table 6. A chi-square difference test indicated that the four groups were comparable in their initial levels and rates of change in their relationships with peers ($\Delta\chi^2 = 4.70$, $\Delta df = 6$, *ns*). However, the four groups displayed different levels of intercept and slope variances and covariance ($\Delta\chi^2 = 13.13$, $\Delta df = 5$, $p < .05$). As with caregiver relationships, youths who were living in the home at baseline (i.e., Groups 2 and 4) displayed significantly greater individual variability in their initial levels of and rates of change in peer relationships compared to those who were in out-of-home care at baseline (i.e., Groups 1 and 3) (see Table 7).

Table 6
Multigroup Tests for Caregiver and Peer Relationships

	χ^2	<i>df</i>	<i>p</i>	CFI	TLI	RMSEA	$\Delta \chi^2$	Δdf	<i>p(d)</i>
<u>Caregiver relationships</u>									
No constraint	12.49	14	.57	1.00	1.02	.00			
Equal factor means	23.37	20	.27	0.96	0.98	.03	10.72	6	<i>ns</i>
Equal factor variances and covariance	54.27	27	.00	0.68	0.86	.07	34.04	7	<.001
<u>Peer relationships</u>									
No constraint	15.99	9	0.07	0.96	0.95	0.06			
Equal factor means	21.17	15	0.13	0.97	0.98	0.04	4.70	6	<i>ns</i>
Equal factor variances and covariance	33.05	20	0.03	0.93	0.96	0.05	13.13	5	<.05

Table 7
Factor Variances and Covariance by Placement Groups

	Group 1	Group 2	Group 3	Group 4
<u>Caregiver relationships</u>				
Variance in intercept	0.17**	0.25***	0.07	0.27***
Variance in slope	0.00	0.04***	0.01	0.14***
Factor correlation	0.00	-.73***	-.36	-.68***
<u>Peer Relationships</u>				
Variance in intercept	35.94	107.33***	47.96***	86.92*
Variance in slope	13.93	10.45*	0.00	9.31
Factor correlation	.30	-.73 ***	0.00	-.74***

Note. Group 1: OOH youth, Group 2: in-home youth, Group 3: initial OOH youth, Group 4: initial in-home youth.

Results summary of multigroup analyses.

Multigroup analyses were conducted separately for youths' internalizing behavior problems, externalizing behavior problems, relationship with caregivers, and relationship with peers to examine if there were significant differences in any of these variables by youths' placement status. For each variable, no significant differences were observed between groups' initial levels or rates of change over time. The four placement groups were found to be comparable in the overall initial levels and rates of change in their internalizing and externalizing behavior problems and their relationships with caregivers and peers. The results supported Hypotheses 1.1B and 1.2B, which predicted that the rates of change in youths' internalizing and externalizing behavior problems would not significantly differ by placement status. However, the results did not support Hypotheses 1.1A and 1.2A, which posited that youths in out-of-home placement would exhibit higher internalizing and externalizing behavior problems at the initial time than those remaining in home.

Though between-group differences were not observed for any of the variables, youths reported individual variability within groups for internalizing behavior problems and for their relationships with caregivers and peers. For internalizing behavior problems, youths at home (Group 2) exhibited less variability both in the intercept and in the slope compared to youths in the other three groups. Individual variability was most noticeable for youth who were placed out of the home initially and returned home later (Group 3). With respect to youths' relationships with caregivers, youths who were at home initially (Groups 2 and 4) displayed greater individual variability in their intercepts and slopes compared to those placed out of the home initially (Groups 1 and 3). The same pattern

was observed in terms of youths' peer relationships. Youth who were at home initially (Groups 2 and 4) exhibited greater within-group variability in their intercepts and slopes than those placed out of the home initially (Groups 1 and 3).

Caregiver Relationships and Behavior Problems

The second set of research questions focused on the correlation between youths' relationships with caregivers and their behavior problems. It was hypothesized that (a) positive relationships with caregivers at baseline would be negatively related to internalizing and externalizing behavior problems at baseline (Hypotheses 2.1A and 2.2A), (b) positive relationships with caregivers at baseline would be negatively related to changes in internalizing and externalizing behavior problems over time (Hypotheses 2.1B and 2.2B), and (c) changes in youths' relationships with caregivers would be related to changes in their internalizing and externalizing behavior problems over time (Hypotheses 2.1C and 2.2C).

Caregiver relationship and internalizing behavior problems.

First, the relationship between caregiver relationships and internalizing behavior problems was investigated. The presence of within-time residual correlations was tested using a chi-square difference test. With residual correlation assumed, the model fit significantly improved ($\Delta\chi^2 = 9.29$, $\Delta df = 3$, $p < .05$), indicating that there were within-time correlations between the two variables.

The model fit the data well ($\chi^2 = 3.78$, ns , CFI = 1.00, TLI = 1.00, RMSEA = 0.00; see Table 8). Figure 7 presents the parameter estimates of the multivariate model for caregiver relationships and internalizing behavior problems. Initial caregiver relationship

significantly predicted the intercept of internalizing behavior problems. The standardized coefficient was -0.60 ($SE = 0.09, p < .001$), indicating that more positive caregiver relationships at baseline were associated with lower internalizing behavior problems at baseline. The slope of positive caregiver relationships was negatively related to the slope of internalizing behavior problems ($\beta = -0.43, SE = 0.18, p < .05$). As the rate of change in caregiver relationship increased over time, there was a corresponding decline in the reported rates of internalizing behavior problems. The results indicated that a substantial portion of the individual variation in internalizing behavior problems could be explained by caregiver-child relationships. Initial caregiver relationship was not significantly related to the rate of change of internalizing behavior problems over time.

The results supported Hypothesis 2.1A, which predicted that the initial caregiver relationship would be negatively related to the initial level of internalizing behavior problems. Support was also found for Hypothesis 2.1C, which predicted that changes in youths' caregiver relationships would be negatively related to changes in their internalizing behavior problems over time. On the contrary, the results did not support Hypothesis 2.1B, which predicted that the initial relationship with the caregiver would be negatively related to the change in internalizing behavior problems over time.

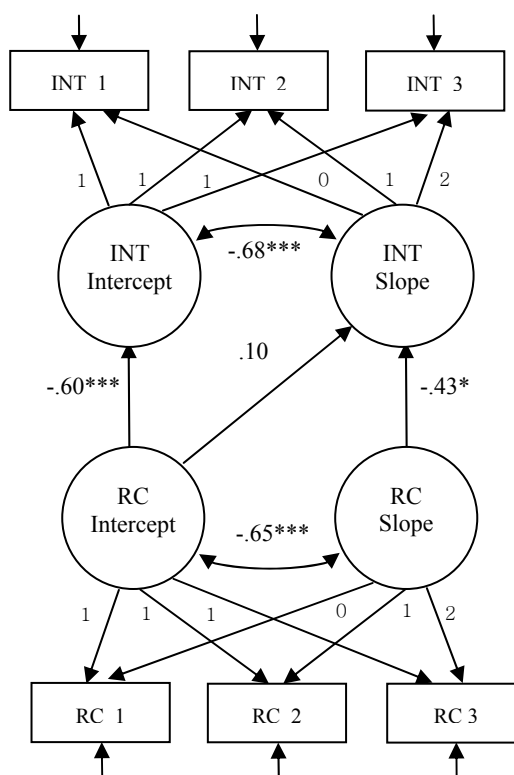

Figure 7. Multivariate growth curve model for caregiver relationships and internalizing behavior problems. *Note.* RC = relationship with caregivers, INT = internalizing behavior problems; all parameter estimates are in standardized metric units; residual correlations within time between the two constructs were estimated but were not included for simplicity; all factor loadings were set to predetermined values and thus were not estimated; * $p < .05$. ** $p < .01$. *** $p < .001$.

Table 8

Model Fit Indices for Multivariate Growth Models

	χ^2	df	p	CFI	TLI	RMSEA
Caregiver – internalizing	3.783	5	0.58	1.00	1.00	0.00
Caregiver – externalizing	8.17	5	0.15	0.99	0.98	0.03
Peer – internalizing	15.03	8	0.06	0.98	0.97	0.03
Peer – externalizing	6.89	8	0.55	1.00	1.00	0.00

Caregiver relationship and externalizing behavior problems.

Next, the relationship between caregiver relationship and externalizing behavior problems was investigated (see Figure 8). As described earlier, the intercept and slope factors of externalizing behavior problems were regressed on the intercept of caregiver relationships. The slope of externalizing behavior problems was regressed on the slope of caregiver relationships. The addition of within-time residual correlations significantly improved the model's fit ($\Delta\chi^2 = 10.50$, $\Delta df = 3$, $p < .05$), and thus the residual correlations were retained.

The model fit the data well ($\chi^2 = 8.17$, *ns*, CFI = 0.99, TLI = 0.98, RMSEA = 0.03). The initial caregiver relationship was significantly related to the initial level of externalizing behavior problems ($\beta = -0.54$, $SE = 0.09$, $p < .001$). Youths with a more positive caregiver relationship at baseline tended to display fewer externalizing behavior problems at baseline. This supports Hypothesis 2.2A, which predicted that the caregiver-child relationship at baseline would be negatively related to externalizing behavioral problems at baseline. However, the initial level of and rate of change in caregiver relationships were not predictive of the rate of change in externalizing behavior problems, which was inconsistent with Hypothesis 2.2B (that the caregiver-child relationship at baseline would be negatively related to externalizing behavioral problems over time) and Hypothesis 2.2C (that changes in the caregiver-child relationship would be negatively related to changes in youths' externalizing behavioral problems over time).

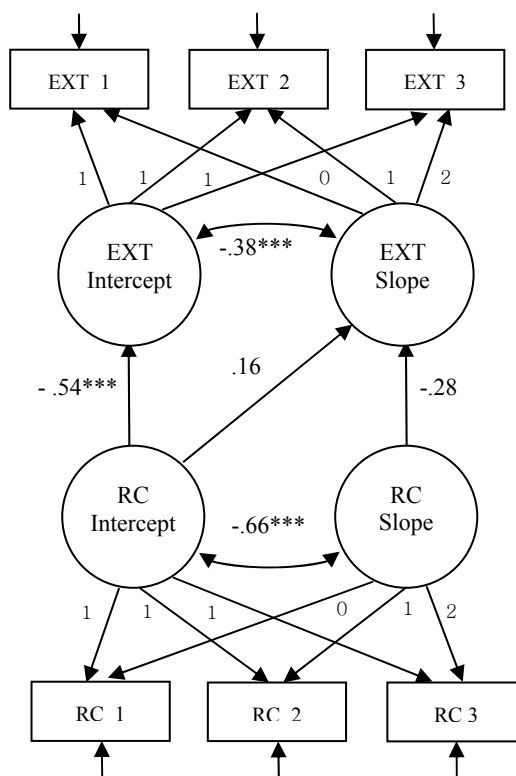

Figure 8. Multivariate growth curve model for caregiver relationships and externalizing behavior problems. *Note.* RC = relationship with caregivers, EXT = externalizing behavior problems; all parameter estimates are in standardized metric; residual correlations within time between the two constructs were estimated but were not included for simplicity; all factor loadings were set to predetermined values and thus were not estimated; * $p < .05$. ** $p < .01$. *** $p < .001$.

Summary of the conditional models: Caregiver relationship

The correlations between caregiver-child relationship and youths' internalizing and externalizing behavior problems were investigated using multivariate conditional models. For internalizing behavior problems, the results indicated that the initial quality of the caregiver relationship significantly predicted the intercept of internalizing behavior problems. The hypotheses were partially supported. More positive caregiver relationships at baseline were associated with lower internalizing behavior problems at baseline

(Hypothesis 2.1A). The slope of positive caregiver relationships was negatively related to the slope of internalizing behavior problems (Hypothesis 2.1C). However, the initial quality of the caregiver relationship was not significantly related to the rate of change of internalizing behavior problems over time (Hypothesis 2.1B).

With regard to the externalizing behavior problems, the initial caregiver relationship was significantly related to the initial level of externalizing behavior problems. Youths with more positive caregiver relationships displayed fewer externalizing behavior problems at baseline, supporting Hypothesis 2.2A. The results did not support Hypothesis 2.2B, which predicted that the initial quality of the caregiver relationship would be negatively related to the change in externalizing behavioral problems over time. Hypothesis 2.2C, which stated that changes in the caregiver-child relationship would be negatively related to changes in externalizing behavioral problems over time, was not supported either.

Peer Relationships and Behavior Problems

The third set of research questions focused on the relationship between youths' relationships with peers and their behavior problems. It was hypothesized that (a) negative relationships with peers at baseline would be positively related to internalizing and externalizing behavior problems at baseline (Hypotheses 3.1A and 3.2A), (b) negative relationships with caregivers at baseline would be positively related to changes in internalizing and externalizing behavior problems over time (Hypotheses 3.1B and 3.2B), (c) changes in youths' relationships with peers would be related to changes in their internalizing and externalizing behavior problems over time (Hypotheses 3.1C and 3.2C). The same series of multivariate growth curve models described above was run

for the peer-relationship and behavior-problem variables.

Peer relationship and internalizing behavior problems.

Figure 9 presents the hypothesized model and parameter estimates for peer relationship and internalizing behavior problems. The intercepts and slopes of youths' internalizing behavior problems were regressed on the intercepts of peer relationships. To explore how the rates of change in peer relationships predicted the rates of change in internalizing behavior problems over time, the slopes of the internalizing behavior problems were regressed on the slope of peer relationships. The growth factors of each construct were allowed to covary. The adequacy of the contemporaneous residual correlations between the two constructs (i.e., Time 1 peer relationship residual with Time 1 internalizing behavior problems residual) was tested using a chi-square difference test. The addition of contemporaneous residual correlations did not significantly improve the model's fit ($\Delta\chi^2 = 1.32$, $\Delta df = 3$, *ns*), and thus the residual correlations were rejected.

The model fit indices produced a good fit ($\chi^2 = 15.03$, *ns*, CFI = 0.98, TLI = 0.97, RMSEA = 0.03). The standardized coefficients indicated that the effect of the initial peer relationships on the initial level of internalizing behavior problems was significant ($\beta = 0.69$, $SE = 0.08$, $p < .001$). The parameters indicated that more negative initial peer relationships were associated with more initial internalizing behavior problems. The slope of peer relationships was associated with the slope of internalizing behavior problems ($\beta = 0.57$, $SE = 0.15$, $p < .001$). Youths who reported a greater decrease in their negative peer relationships demonstrated a significantly greater decline in their internalizing behavior problems. The results indicate that a substantial portion of the individual variation in internalizing behavior problems could be explained by peer relationships.

The initial quality of peer relationships was not related to the rate of change of internalizing behavior problems. The results supported Hypothesis 3.1A, which stated that the initial quality of the peer relationship would be negatively related to the initial level of internalizing behavior problems, and Hypothesis 3.1C, which stated that changes in youths' peer relationships would be negatively related to changes in their internalizing behavior problems over time. On the contrary, the results did not support Hypothesis 3.1B, which stated that the initial quality of the relationship with the caregiver would be negatively related to the change in internalizing behavior problems over time.

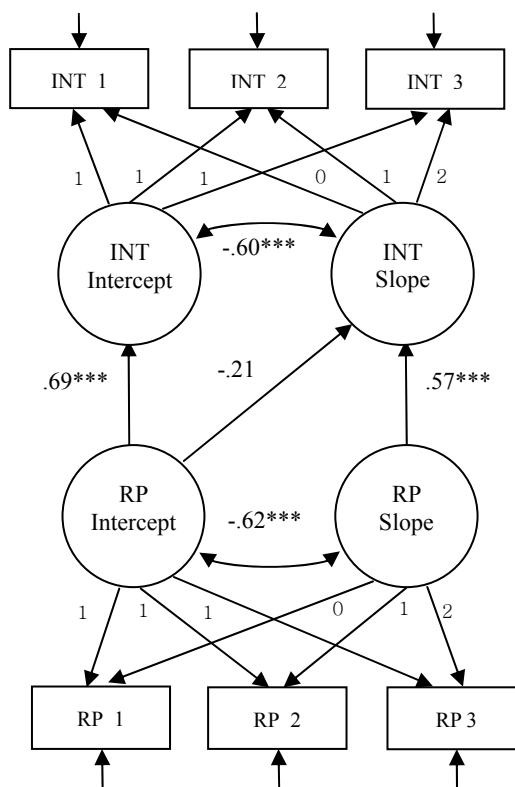

Figure 9. Multivariate growth curve model for peer relationships and internalizing behavior problems. *Note.* RP = relationship with peer, INT = internalizing behavior problems; all parameter estimates are in standardized metric units; all factor loadings were set to predetermined values and thus were not estimated; * $p < .05$. ** $p < .01$. *** $p < .001$.

Peer relationship and externalizing behavior problems.

Next, the same multivariate model was run for externalizing behavior problems (see Figure 10). As with internalizing behavior problems, the model fit did not improve when residual correlations were assumed. Thus, residual correlations were rejected. The model fit indices produced an excellent fit ($\chi^2 = 6.89$, *ns*, CFI = 1.00, TLI = 1.00, RMSEA = 0.00). The initial quality of the peer relationship was positively related to the initial level of externalizing problems ($\beta = 0.50$, $SE = 0.09$, $p < .001$). This indicates that youth with more negative peer relationships at baseline tended to display a higher level of externalizing behavior problems at baseline. The slope of peer relationships was significantly related to the slope of externalizing behavior problems ($\beta = 0.44$, $SE = 0.21$, $p < .05$). Youth who reported a greater decrease in their negative peer relationships had a significantly greater decline in their externalizing behavior problems. The results indicate that a substantial portion of the individual variation in externalizing behavior problems could be explained by peer relationships. The initial level of peer relationships were not significantly related to the rate of change of externalizing behavior problems. The results supported the hypothesis that the initial quality of the peer relationship would be negatively related to the initial level of externalizing behavior problems (Hypothesis 3.2A) and the hypothesis that changes in youths' peer relationships would be negatively related to changes in their externalizing behavior problems over time (Hypothesis 3.2C). However, the results did not support the hypothesis that the initial quality of the relationship with caregivers would be negatively related to the change in externalizing behavior problems over time (Hypothesis 3.2B).

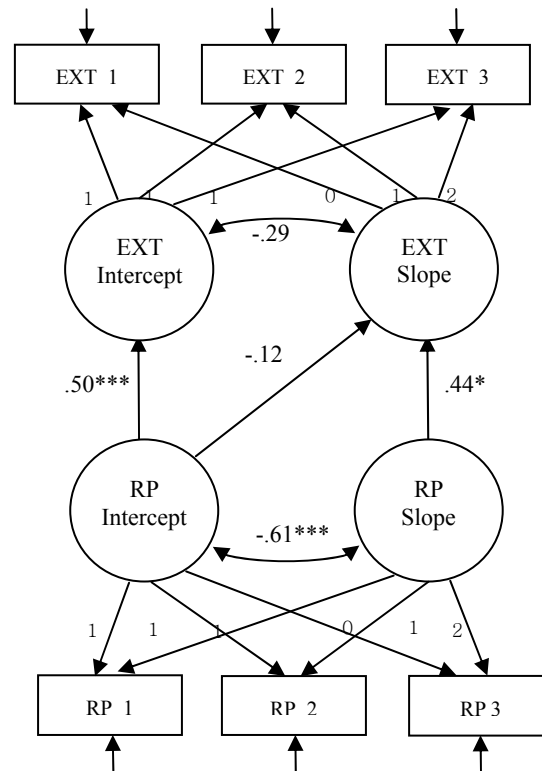

Figure 10. Multivariate growth curve model for peer relationships and externalizing behavior problems. *Note.* RP = relationship with peer, EXT = externalizing behavior problems; all parameter estimates are in standardized metric units; all factor loadings were set to predetermined values and thus were not estimated; * $p < .05$. ** $p < .01$. *** $p < .001$.

Results summary of the conditional models: Peer relationship

The relationships between youths' peer relationships and their internalizing and externalizing behavior problems were investigated using multivariate conditional models. The results partially supported the hypotheses. For both internalizing and externalizing behavior problems, the initial quality of the peer relationship was significantly related to the initial level of behavior problems, supporting Hypotheses 3.1A and 3.2B. Hypotheses, which stated that the changes in peer relationships would be related to the changes in internalizing (Hypothesis 3.1C) and externalizing (Hypothesis 3.2C) behavior problems

over time, was also supported. For both internalizing and externalizing problems, the initial quality of the peer relationship was not significantly related to the rates of change in behavior problems, which was inconsistent with Hypotheses 3.1B and 3.2B.

Causal Relationships among Caregiver Relationships, Peer Relationships, and Behavior Problems

The fourth set of research questions aimed to assess the causal relationships among caregiver relationships, peer relationships, and behavior problems. It was hypothesized that there would be temporal causal relationships between three variables over three time points: (a) caregiver relationships would predict peer relationships and internalizing and externalizing behavior problems at later time points (Hypotheses 4.1A and 4.2A, respectively), (b) peer relationships would predict caregiver relationships and internalizing and externalizing behavior problems at later time points (Hypotheses 4.1B and 4.2B, respectively), and (c) internalizing and externalizing behavior problems would predict caregiver and peer relationships at later time points (Hypotheses 4.1C and 4.2C, respectively).

Caregiver Relationships, Peer Relationships, and Internalizing Behavior Problems

The set of models described in Chapter 3 was conducted for caregiver relationships, peer relationships, and internalizing behavior problems. The fit indices and chi-square difference tests for the hypothesized models are presented in Table 9. All models provided a good fit to the data (i.e., CFIs ranged from 0.94 to 0.97, TLIs ranged from .90 to .94, and RMSEAs ranged from 0.03 to 0.04). According to the change in the chi-square test for nested models, compared to the most restrictive baseline model

(Model 1), all three subsequent models (Models 2-4) provided a significantly better fit. The change in the chi-square test was significant in each case, indicating that, comparatively, the least restrictive model provided a significantly better fit than the other models. The reciprocal model provided a significantly better fit compared to Models 1-4 (chi-square difference tests comparing reciprocal model with Models 2-4 are not presented in the table). The final model (Model 6) was developed by modifying the reciprocal model. Nonsignificant paths were eliminated from Model 5, and the trimmed final model was accepted as the most parsimonious, best-fitting model. The final model fit the data well ($\chi^2 = 33.59, p < .05, CFI = 0.97, TLI = 0.94, RMSEA = 0.03$).

Table 9

Model tests for Internalizing Problems, Caregiver and Peer Relationships

	χ^2	<i>df</i>	<i>p</i>	CFI	TLI	RMSEA
M1. Base model	53.97	21	<.001	0.94	0.90	0.04
M2. RC→ RP, INT	38.76	17	<.01	0.94	0.92	0.04
M3. RR→ RC, INT	43.08	17	<.001	0.95	0.90	0.04
M4. INT→RC, RP	39.00	17	<.01	0.96	0.92	0.04
M5. Reciprocal	22.90	9	<.001	0.97	0.90	0.04
M6. Best Model	33.59	18	<.05	0.97	0.94	0.03
Chi-square difference	$\Delta \chi^2$	Δdf	<i>p</i> (d)			
M1-M2	16.20	4	<.01			
M1-M3	11.01	4	<.05			
M1-M4	13.61	4	<.01			
M1-M5	31.07	12	<.01			
M5-M6	11.16	9	<i>ns</i>			

Note. RC: relationship with caregiver, RP: relationship with peer, INT: internalizing behavior problems.

Figure 11 presents the significant paths and standardized regression coefficients. All autoregressive coefficients were positive and significant. These indicated that the constructs in the model were relatively stable over time (i.e., higher values of earlier measures predicted higher values of later measures). Compared to peer relationships and internalizing problems, caregiver relationships was less stable over time. For caregiver relationships, the standardized autoregressive coefficient was 0.41 ($SE = 0.09, p < .001$) between Time 1 and Time 2 and 0.36 ($SE = 0.07, p < .001$) between Time 2 and Time 3. The coefficients were 0.55 ($SE = 0.06, p < .001$) and 0.50 ($SE = 0.06, p < .001$) for peer relationships at the different time points, respectively. For internalizing behavior problems, the coefficients were 0.53 ($SE = 0.07, p < .001$) between Time 1 and 2 and 0.57 ($SE = 0.05, p < .001$) between Time 2 and 3. The covariance among the three variables at Time 1 and the covariance within the time disturbances at Time 2 and Time 3 were all significant. Regarding the cross-lagged effects, the Time 1 peer relationships predicted internalizing behavior problems at Time 2 ($\beta = 0.14, SE = 0.06, p < .05$). Higher internalizing behavior problems at Time 1 significantly predicted a decrease in positive caregiver relationships at Time 2 ($\beta = -0.17, SE = 0.08, p < .05$). Positive caregiver relationships at Time 2 significantly contributed to a decrease in negative peer relationships at Time 3 ($\beta = -0.13, SE = 0.06, p < .05$).

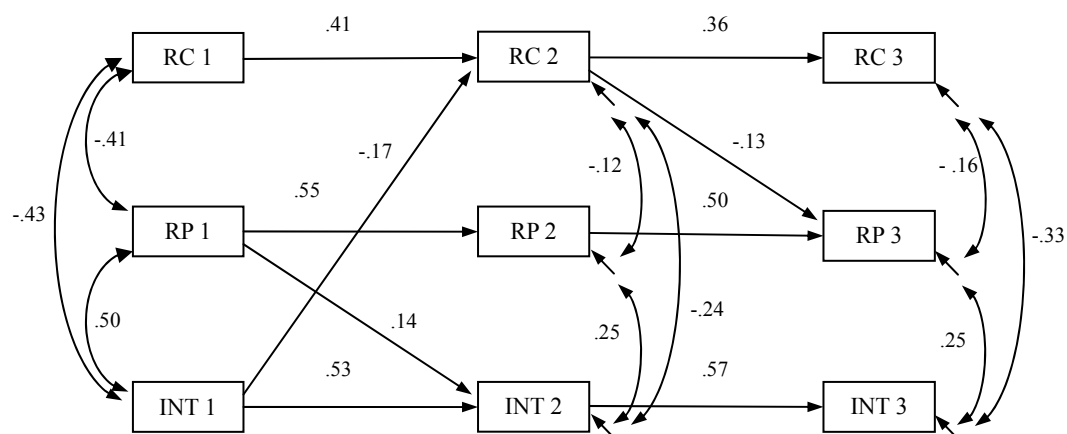

Figure 11. Final model for internalizing behavior problems, caregiver relationships, and peer relationships. Note. RC: relationship with caregiver, RP: relationship with peer, INT: internalizing problems. Only statistically significant paths are presented. All paths shown are statistically significant at the .05 level or better. All values are in standardized metric units.

Caregiver Relationships, Peer Relationships, and Externalizing Behavior Problems

The same set of analyses was run for caregiver relationships, peer relationships, and externalizing behavior problems. The fit indices for the hypothesized models are presented in Table 10. Overall, the models provided a moderate fit to the data (i.e., CFIs ranged from 0.93 to 0.96, TLIs ranged from .87 to .90, and RMSEAs ranged from 0.04 to 0.05). According to the change in the chi-square test for the nested models, compared to the most restrictive baseline model, Models 2 and 4 provided a significantly better fit. However, Model 3 provided no improvement over the base model ($\Delta\chi^2 = 3.25$, $\Delta df = 4$, ns). None of the cross-lagged paths in Model 3 were significant. Given peer relationship was not predictive of caregiver relationship and externalizing behavior problems, the reciprocal model was run as a combined model of Model 2 and Model 4 (i.e., caregiver relationship being predictive of peer relationship and externalizing problems, and externalizing problems being predictive of caregiver relationship and peer relationship).

The reciprocal model (Model 5) provided a significantly better fit than Models 1-4 (chi-square difference tests comparing the reciprocal model with Models 2-4 are not presented in the table). The final model (Model 6) was developed by modifying the reciprocal model. Nonsignificant paths were eliminated from Model 5, and the trimmed final model was accepted as the most parsimonious, best-fitting model. The final model provided a good fit ($\chi^2 = 42.17, p < .001, CFI = 0.97, TLI = 0.92, RMSEA = 0.04$).

Figure 12 presents the significant paths and standardized regression coefficients. All autoregressive coefficients were positive and significant. The externalizing behavior problems were the most stable over time ($\beta = 0.63, SE = 0.05, p < .001$ for Time 1 and

Table 10

Model tests for Externalizing Problems, Caregiver and Peer Relationships

	χ^2	<i>df</i>	<i>P</i>	CFI	TLI	RMSEA
M1. Base model	58.76	21	<.001	0.93	0.89	0.04
M2. RC→ RP, EXT	46.72	17	<.001	0.95	0.90	0.04
M3. RP→ RC, EXT	54.90	17	<.001	0.93	0.87	0.05
M4. EXT→RC, RP	46.42	17	<.001	0.95	0.90	0.04
M5. Reciprocal	36.27	13	<.001	0.96	0.89	0.04
M6. Best Mode	42.17	18	<.001	0.96	0.92	0.04
Chi-square difference	$\Delta\chi^2$	Δdf	<i>p</i> (d)			
M1-M2	12.17	4	<.05			
M1-M3	3.25	4	<i>ns</i>			
M1-M4	12.04	4	<.05			
M1-M5	22.48	8	<.01			
M5-M6	6.73	5	<i>ns</i>			

Note. RC: relationship with caregiver, RP: relationship with peer, EXT: externalizing behavior problems.

Time 2 and $\beta = 0.62$, $SE = 0.05$, $p < .001$ for Time 2 and Time 3). The covariances among the three variables at Time 1 were all significant. The covariances of the within-time disturbances between caregiver relationship and externalizing behavior problems at Times 2 and 3 were also all significant; however, the disturbances covariances between peer relationships and externalizing behavior problems at Times 2 and 3 were not significant. Regarding cross-lagged effects, no significant effects were found between Time 1 and Time 2. Caregiver relationships at Time 2 significantly predicted peer relationships at Time 3 ($\beta = -0.12$, $SE = 0.06$, $p < .05$). Externalizing behavior problems at Time 2 predicted caregiver relationships ($B = -0.15$, $SE = 0.06$, $p < .05$) and peer relationships ($\beta = 0.14$, $SE = 0.06$, $p < .05$) at Time 3.

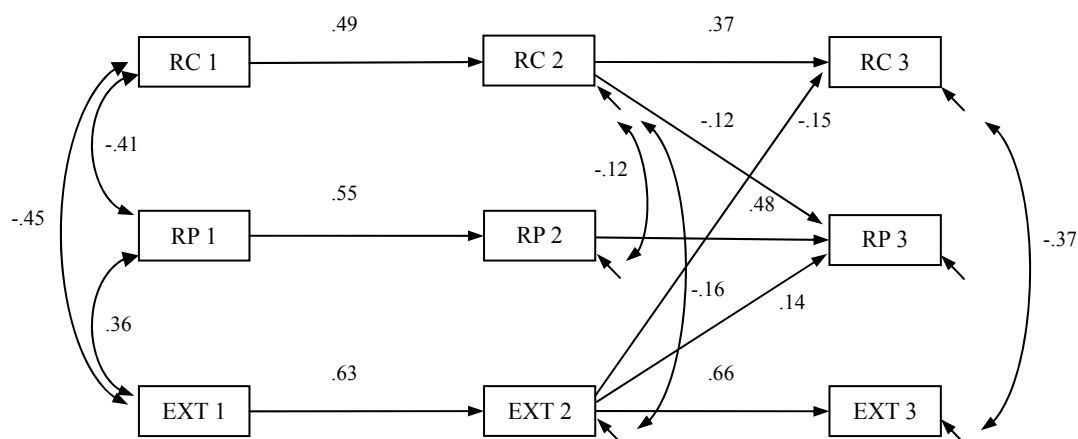

Figure 12. Final model for externalizing behavior problems, caregiver relationships, and peer relationships. *Note.* RC: relationship with caregiver, RP: relationship with peer, YBE: youth externalizing behavior problems. Only statistically significant paths are presented; All paths shown are statistically significant at the .05 level or better. All values are in standardized metric units.

Summary of the results for the autoregressive cross-lagged models.

The final set of research questions aimed to investigate the causal order underlying youths' relationships with caregivers, relationships with peers, and their behavior problems. ARCL models were conducted separately for internalizing behavior problems and externalizing behavior problems. The results indicated that youths' internalizing and externalizing behavior problems, their relationships with caregivers, and their relationships with peers were all stable over time. Stability over time was most noticeable in the internalizing and externalizing behavior problems. Youths' relationships with their caregivers were comparatively less stable over time.

With regard to cross-lagged paths, some significant paths were observed after taking into account the effects of the previous levels of the outcomes on the levels at later time points. For internalizing behavior problems, Time 1 peer relationship affected Time 2 internalizing behavior problems. Time 1 internalizing behavior problems affected Time 2 caregiver relationships. Time 2 caregiver relationships affected Time 3 peer relationships.

For externalizing behavior problems, no cross-lagged paths were found between Time 1 and Time 2. Time 2 externalizing behavior problems affected Time 3 caregiver relationships and peer relationships. Time 2 caregiver relationships also affected Time 3 peer relationships.

CHAPTER 5

DISCUSSION

This study looked at the trajectories of the behavioral functioning of adolescents over a 36-month period after their initial contact with Child Protective Services (CPS). Guided by a framework of attachment and resilience theory, the analyses examined how youth in the child welfare system fare in terms of their internalizing/externalizing behavior problems and their relationships with caregivers and peers. The analyses also explored whether removing children from their biological families predicted distinct trajectories of behavior functioning compared to those who remained at home. Specifically, there were four main research focuses: (a) whether youth exhibited distinct developmental trajectory by placement status subsequent to the initial CPS investigation; (b) how youths' relationships with caregivers were related to their behavioral problems; (c) how youths' relationships with their peers were related to their behavioral problems; and (d) the possible causal order underlying youths' behavior problems, their relationships with caregivers, and relationships with peers.

This chapter provides a summary and interpretation of the results. The chapter also suggests implications for theory, research, and child welfare policy and practice. Finally, the study's limitations and directions for future research are discussed.

Summary and Interpretation of Results

Trajectory of Behavior Problems over Time

Results from the latent growth curve model revealed that youths reported

significantly decreasing internalizing behavior problems over the study period of 36 months. There was considerable individual variability in the initial level and rate of change in internalizing problems over time. That is, some youths showed improvement in their internalizing problems whereas others did not. This indicates that there are factors that may explain the variability in the degree of change. On the other hand, youths' externalizing behavior problems remained considerably stable over time, with relatively little individual variability in the rates of change of those problems. These results suggest that externalizing problems tend to be prevalent among youths in the child welfare system and are likely to persist over time. The findings are consistent with previous studies on children and adolescent problems behaviors, which have generally indicated that externalizing behaviors show somewhat higher stability than internalizing behaviors (Costello, Farmer, Angold, Burns, & Erkanli, 1997). The results are also similar to those of studies that suggest that children in the child welfare system are more likely to exhibit externalizing behavior problems than internalizing problems (Visser, Van der Ende, Koot, & Verhulst, 2003).

Group Differences

Most studies that have examined the longitudinal effects of out-of-home placement on children's outcomes have used out-of-home placement at baseline, length of time in out-of-home placement, or number of placement arrangements as the predictors of subsequent behavioral outcomes. None of these methods take into account the potential differences in behavioral outcomes between children who move between different placement settings. For example, youths who are placed in out-of-home care after the close of an investigation and continuously remain in such care might be very

different from those who exit out-of-home care and reunify with their biological parents or from those who are in the home initially and then enter out-of-home care later. In order to investigate behavioral outcomes by placement pattern, the current study divided youth into four placement groups: youth who remained in out-of-home care continuously (Group 1), youth who remained in the home continuously (Group 2), those who were removed from the home initially and then returned home at any subsequent wave (Group 3), and those who were in the home initially and then removed from the home at any subsequent wave (Group 4).

When group differences were investigated with multigroup analyses, contrary to the hypotheses, the four groups did not display significant differences in the initial level of internalizing or externalizing problems. Previous studies reported higher behavior problems among foster children, and behavior problems, particularly externalizing problems, were reported as one of the main reasons children are placed in out-of-home care (Barth, Green, Guo, & McCrae, 2007; Newton, Litrownik, & Landsverk, 2000). The contradictory findings in the current study could be due to the time lag between the report of abuse and baseline data collection: The initial data were collected 2-6 months after the close of the investigation. Youths with more behavioral problems might have been receiving services at the time of the baseline data collection. To the extent that this was the case, service use might have offset the pre-existing behavioral functioning between youth placed in out-of-home care and those who were still in the home at baseline.

In support of the hypotheses, the rate of change was not significantly different across groups for either internalizing or externalizing problems. These results suggest that out-of-home placement did not have a negative effect on youths' internalizing and

externalizing behavioral problems. This is at odds with most of the previous literature, which has indicated that separation from the parents is harmful to child development (Berkowitz, G., & Klee, 1992; Orme & Buelher, 2001). The differences in findings may be due to methodological limitations of the previous studies on foster care. Most studies on foster children have not utilized an appropriate comparison group or have not taken into account emotional and behavioral functioning before the placement. Previous studies have also neglected to examine long-term functioning. This finding illustrates the importance of a sound methodology with an appropriate comparison group.

It is also notable that, though there was no difference in the mean of the initial level and the slope of internalizing problems across groups, there was significant within-group variance. In particular, youths who remained in the home consistently (Group 2) showed the least individual variability around the group means compared to the other three groups. Youths in the continuous OOH group and youths who experienced a placement change reported greater individual variability in their behavioral functioning over time. Interestingly, youths who were placed in out-of-home care initially and then reunified with the family (Group 3) reported the greatest variability. These findings indicate that reunification or removal from the biological family may have heterogeneous effects on youth. Reunification or removal from the family may accelerate or mitigate the internalizing problems of youth. Or they may be so troubled that they are moving in or out of out-of-home care. Further research can examine mechanisms that link placement change and behavior problems as well as factors that may explain the individual variance among youth who experience placement change.

In regard to externalizing behavioral problems, within-group variance was not

found in any of the four groups. As discussed earlier, this suggests that externalizing behavior problems among youths involved with CWS were prevalent regardless of placement type. The results highlight the need for services for both foster youth and youths at home. Previous studies have indicated that foster youth are more likely to receive mental health services (Halfon et al., 1992). The findings from this study indicate that youths who remain in the home after the close of the investigation have service needs for their externalizing problems and that those services should be provided continuously over time. In addition, the results from the current study indicate that about one fifth of youths who were in the home initially were placed in out-of-home care after the close of the investigation (see sample description in Chapter 4). Adequate service provision to improve externalizing problems for in-home youth may reduce the risk of later removal from their biological families.

Trajectory of Relationships with Caregivers and Peers

As a second area of investigation, linear growth curve models were conducted separately for caregiver relationships and peer relationships to understand how youths with a disrupted relationship with the primary caregiver built relationships over time with significant others such as caregivers (either foster or abusive biological caregiver) and peers in school. The results indicated that, on average, youths tended to have positive perceptions of their relationships with caregivers (3.30 out of a 4-point scale at baseline, with higher scores indicating more positive relationships) and peers (1.92 out of a 5-point scale at baseline, with higher scores indicating more loneliness and peer rejection). Latent growth curve models indicated that youths' caregiver relationships remained considerably stable over time, and their peer relationships improved over time. Unlike previous studies

reporting high relationship difficulties among foster youth (Orme & Buehler, 2001), when group differences were tested for, none of the four groups showed significant differences in initial level or rate of change in caregiver or peer relationships.

Interestingly, youth who were in the home at baseline (Groups 2 and 4) reported greater individual variability in the initial level and rate of change in their relationships with caregivers and peers compared to those in out-of-home care at baseline. The present findings indicate that some at-home youth have relational difficulties with their biological caregivers and peers in school. Additionally, the results are in line with the high removal rate among at-home youth found in the current study and also support previous studies reporting a high recurrence rate of abuse among this population (Taussig, Clyman, & Landsverk, 2002).

These findings are important for a couple of reasons. First, the results demonstrate the significance of continuing parenting training with abusive caregivers. By improving parenting and caregiver-youth relationship difficulties, parenting training could prevent the recurrence of abuse and the removal from the home and thus provide a safe permanent care environment for youth involved in the child welfare system. The results also suggest that more attention should be paid to at-home youth who experience difficulties in their relationships with peers and who do not engage well in school.

Caregiver Relationships and Behavior Problems

With respect to internalizing problems, as hypothesized, the quality of caregiver relationships at baseline was significantly related to the initial level of internalizing problems. Furthermore, the change in caregiver relationships was significantly associated with the change in internalizing problems. These findings suggest that improving

caregiver relationships over time would be associated with decreasing internalizing behavior problems. Regarding externalizing behavior problems, the initial quality of the caregiver relationship was significantly related to the initial level of externalizing behavior problems. However, contrary to the hypotheses, change in caregiver relationship quality was not associated with change in the level of externalizing behavior problems. This could have been due to the stability of and small individual variability in youths' externalizing problems in this study. As demonstrated by the current study and previous literature as well, externalizing problems of youth in the CWS are likely to be so prevalent and persistent over time that they are not easily changed. This indicates the need for services to address the externalizing problems of youth in the CWS. Taken together, the results partially support the proposition of attachment theory that caregiver-child relationship quality is related to internalizing and externalizing problems.

Peer Relationships and Behavior Problems

As predicted in the hypotheses, the initial quality of peer relationships was significantly related to the initial level of internalizing and externalizing behavior problems. The change in peer relationships was also significantly associated with the change in internalizing and externalizing behavior problems over time. These findings suggest that improving peer relationships over time would be associated with decreasing behavior problems. These findings provide evidence that peer relationships play an important role in predicting youths' behavior problems. The findings support the assertion that peers may have a significant influence in adolescent youths' behavior and provide a buffer against adverse family environments (Price & Brew, 1998).

Causal order among behavior problems, caregiver relationship, and peer relationship

Despite conceptual and methodological strengths, caution should be taken when drawing causal inferences from the latent growth curve models because the observations were measured contemporaneously. In addition, there is the possibility of reverse causality; in particular, youths' behavioral problems may lead to poor relationships with caregivers and peers. The current study evaluated the possibility of reverse causality by utilizing ARCL analyses to evaluate the bidirectional relationships among behavior problems, caregiver relationships, and peer relationships. The results indicated that youths' behavior problems (both internalizing and externalizing) and relationships with caregivers and peers were considerably stable over time. That is, the measures at subsequent time points were very likely to be predicted by the measures of previous time points.

In particular, the stability was most significant in youths' externalizing behavior problems, which is consistent with the results from the growth curve analyses of externalizing problems. This finding is similar to previous research on individuals referred (and not referred) to mental health services that have shown that adolescents demonstrate highly stable problem behaviors over time (Visser, Van der Ende, Koot, & Verhulst, 2003; Hofstra, Van der Ende, & Verhulst, 2000; Costello et al., 1997). In general, these studies have indicated that adolescent problems tend to persist into adulthood to a considerable degree. In particular, adolescents are more likely than younger children to exhibit more stable problem behaviors (Hofstra et al., 2000; Costello et al., 1997).

Cross-lagged paths among the variables were also found above and beyond the

autoregressive effects. In regard to internalizing problems, Time 1 internalizing behavior problems significantly predicted Time 2 caregiver relationships. Time 2 caregiver relationships, in turn, were predictive of Time 3 peer relationships. Time 1 peer relationships were related to Time 2 internalizing behavior problems. Regarding externalizing problems, it is notable that youths' externalizing behavior problems at Time 2 significantly predicted their relationships with caregivers and peers at Time 3. This suggests that youths' externalizing behavioral problems, such as aggression and delinquency, may cause them difficulties in building close relationships with caregivers (either foster parents or abusive biological caregivers) or peers in school. Time 2 caregiver relationships were predictive of Time 3 peer relationships. The cross-lag between caregiver relationships and subsequent peer relationships supports previous findings that children who have insecure attachments are less likely to be liked by peers (Bohlin, Hagekull, & Rydell, 2000).

The results from the ARCL analyses extend the findings from the contemporaneous analyses by providing evidence of the possibility that youths' emotional and behavioral problems influence their relationships with caregivers and peers. Taken together with the findings from the growth curve analyses, the current study indicates that youths' behavioral problems and relationship qualities contribute to each other interactively over time. Future research using observations measured at more than three time points could help us understand more about how the underlying mechanisms contribute to these relationships over the long term.

Implications for Theory, Policy, and Practice

Implications for Theory

How maltreated children attach to caregivers has been a key concern in child welfare research. Attachment theory has provided a useful framework for understanding the critical effects of disrupted parent-child relationships on children's developmental outcomes. In attachment theory, a child's early relationship with the primary caregiver is expected to affect the child's behavioral functioning and interpersonal relationships throughout life. Although the key role of early attachment in building a child's developmental outcomes has been widely studied and agreed upon, attachment can be viewed as an "open model" that is adjustable as the child accepts new experiences and constructs new relationships (Crittenden & Ainsworth, 1989). The open-model view is particularly relevant for adolescents because youth increasingly separate from their family and actively search for new relationships in this developmental stage. Consequently, extrafamilial relationships, such as with peers or important adults, may play a significant role in adolescents' lives.

The results from this study provide evidence in support of the view that the attachment system is an open model. Overall, adolescents in this study could form positive relationships with their caregivers and peers despite a history of maltreatment. In particular, foster youth who were removed from their biological caregivers were able to build close relationships with new caregivers and peers. The results from this study also provide evidence to support the assertion that peer relationships are an important dimension in child development (Price & Brew, 1998). The present findings indicate that relationships with peers were as important as relationships with caregivers; indeed,

youths who had problematic peer relationships were at increased risk of developing emotional problems. In light of these findings, the awareness of the importance of peer relationships, particularly in adolescence, should be increased in the field of attachment and child welfare research.

The findings from this study also support the tenets of the risk and resilience model. This model offers a significant divergence from the theoretical perspective of early research on children in disadvantaged circumstances by focusing on risk factors and maladaptation. From the risk and resilience perspective, some high-risk individuals may be likely to overcome adversity and adapt positively (Luthar et al., 2000). The model also notes the importance of identifying risk and protective factors that make adverse circumstances worse or help guard against them. Youths who experienced maltreatment in the current study were, in general, able to adapt positively and improve in behavioral functioning and interactions with others over time. The results also indicate that youths in the child welfare system exhibit significant individual variability, suggesting the presence of risk and protective factors that may affect their adaptation. Whereas previous studies on foster children have focused on relationship problems and subsequent behavioral malfunctioning in this population, the current study provides evidence that relationships with a new caregiver and peers in school could act as protective factors for adolescents. Even in a population at substantial risk for poor behavioral outcomes, adolescents can form positive relationships that are likely to significantly improve their behavioral outcomes.

Altogether, the results of this study provide support for both attachment theory and the risk and resilience model and enrich the previous research in this field. The

protective factors in this study remain important areas for continued theoretical and empirical investigation of youth in the child welfare system.

Implications for Policy and Practice

Whether children fare better with their biological parents or away from them continues to be an unresolved debate in the field of child welfare. Separation from a biological family may be traumatic for children. On the other hand, removal from a damaging environment to a supportive foster home may be beneficial for child development. The findings from this study indicate that out-of-home placement itself does not have a direct negative effect on the emotional and behavioral problems of adolescents. Instead, the care environment and peer interaction in school were better predictors of adolescent behavior than the location of placement. This suggests that more emphasis should be placed on identifying protective factors and enhancing the resilience of youth in the child welfare system, regardless of whether they are placed in the biological home or in foster care.

The results of this study have several implications for policy, practice, and research. First, the findings from this study highlight the importance of providing continuous services to improve the externalizing problems of youth involved in the child welfare system. The results from this study revealed that youths' externalizing problems tended to be prevalent and persistent over time. Furthermore, youths' externalizing problems were likely to affect their relationships with caregivers and peers. These findings raise questions about the extent to which services and interventions for youth with behavioral problems are effective. Moreover, these findings should challenge child welfare practitioners to increase their efforts to improve prevention and treatment. In

addition, empirical research is necessary to evaluate the effectiveness of existing mental health services and treatment programs and develop more effective services in the future.

Second, the results underscore the need to provide continuous parenting training services to biological and foster caregivers. In particular, the present study found that a considerable number of youth were removed from their families later, which is suggestive of a high recurrence of abuse among at-home youth. It is therefore very important for child welfare practitioners to monitor and assess the parenting and the care environment of at-home youth as well as foster youth. In addition, the finding indicates the need to evaluate existing parenting programs and develop effective services and programs to improve child and caregiver relationships. Parenting training is the most common service provided to parents involved with CPS (Casanueva, Martin, Runyan, Barth, & Bradely, 2008); despite this, child welfare research has typically focused on the treatment of developmental problems in maltreated children, and much less research has been conducted on parenting training for maltreating parents (Hurlburt, Barth, Leslie, Landsverk, & McCrae, 2007). Moreover, the effectiveness of existing parenting training programs has rarely been evaluated (Casanueva et al., 2008; Hurlburt et al., 2007). Efforts to develop and provide more effective training by child welfare practitioners and researchers can help reduce the recurrence of abuse and improve the developmental functioning of children in the child welfare system.

Third, services to enhance youths' peer interactions could help them adapt more positively. The results from this study indicated that positive peer interaction in school was linked to decreasing internalizing problems. Positive peer interaction may mitigate some of the adverse consequences of maltreatment and separation from the biological

family. On the other hand, rejection by peers may exacerbate existing mental health problems initially caused by maltreatment (Price & Brew, 1998). In spite of the potentially significant impact on adolescents, peer relationships have not been addressed much in child welfare research and practice. Child welfare practitioners and mental health providers need to note the important role that peers can play in the development of child welfare youths and assess and treat problems that these youths may have in their interactions with peers. Caregivers (biological or foster caregivers) and teachers also must monitor youths' peer interactions and help them in their relationships with peers. Teachers can play a critical role in providing information and improving youths' peer interactions in school (Price & Brew, 1998). The child welfare system may need to collaborate with schools to encourage positive interactions with peers and teachers. Future research on youths' relationships with their teachers will provide a better understanding of the role that the teacher can play in promoting peer interaction and improving the behavioral adaptation of youths in the child welfare system.

The finding from this study that youths' behavioral problems and relationship quality contribute to each other bidirectionally over time suggests that integrated service provision to children and families could be more effective in promoting positive adaptation for child welfare youth. Interventions could be coordinated with teachers to provide parenting training for caregivers and services for youths to improve their behavioral problems and promote their interactions with peers and social skills. It is recommended that practitioners take into consideration youths' behavioral problems and their relationships with their caregivers and peers together in the assessment of and service provision for the mental health needs of youth in the child welfare system. Such an

integrative approach will help provide more comprehensive and effective services to children and families.

Limitations

Despite conceptual and methodological strengths, the current study has certain limitations.

First, the data were available at only three time points over 3 years. As just three periods of data were available, a linear growth pattern was assumed to estimate the trajectory over time in the current study. Future studies with data collected at four time points or more could test the shape of the growth curve (i.e., whether it is linear or nonlinear). In addition, the current study tracked youth developing into late adolescence over 3 years. Entering young adulthood may present considerable challenges to youth in the child welfare system, particularly to foster youth who are aging out of foster care. A longer term examination of how youth at home and those in out-of-home care function as they enter into young adulthood would provide more comprehensive and significant information on how to provide support services for these children.

The second limitation is that the behavior problems in the present study are based on youths' self-reports. Self-reported data were used in this study because different caregivers or teachers may have been interviewed over time, and they may have had limited knowledge of the adolescents' behaviors. Self-reports may be more reliable with adolescent youths because they have advanced cognitive abilities that allow them to assess their behavioral problems (Ollendick, Grills, & King, 2001). Nevertheless, self-reported behavior may not be representative of actual behavior, and thus the sole reliance on self-reports may have led to an inaccurate estimation of the youths' behavioral

problems. Utilizing information from multiple reporters (e.g., caregivers and teachers) in the assessment of youths' behavioral problems would provide more reliable estimates of the outcomes (e.g., Simmel, Lee, & Kim, 2009).

Another limitation is the issue of missing data. The sample for the current study only included cases for which information on placement status was available at all three time points. The cases that were excluded from the analyses may have been able to provide some important information about the variables of interest. However, after running an attrition analysis (see sample in Chapter 3), this limitation seems minimal since the final sample and the excluded cases were not significantly different on variables of interest as well as on demographic variables.

Directions for Future Research

In addition to future studies that address the limitations discussed above, additional studies can enrich the findings from the current study and thus make advances in the existing child welfare literature.

The current study provides important information on youth in the child welfare system by closely examining their functioning over time by placement patterns. Very limited research has investigated the developmental outcomes of youth who have experienced changes in their placement. A few of these studies have been conducted on foster care youth who were reunified with family or re-entered foster care (e.g., Kimberlin, Anthony, & Austin, 2009). However, virtually no study has tracked the functioning of youth who were removed from the home and entered foster care at a later time. Additional studies are necessary to investigate the characteristics of youth by placement move patterns and the risk and protective factors related to each placement

group.

In addition, multigroup tests across four placement groups were not conducted for multivariate growth modeling and ARCL in the current study. Variances in the intercepts or slopes of certain variables were found to be close to zero in some placement groups in the current study, and this made it difficult to estimate the relation between variables, or to compare across the four groups. Between groups, there may be differences in the hypothesized relations between variables. For example, caregiver relationships may be significantly related to internalizing problems in one group, whereas the same relationship may not be significant in another group. Future study can examine if caregiver and peer relationships and behavior problems are associated in each of four groups. A closer examination by placement groups will provide valuable information on how to create more targeted and effective interventions for youth and families in each group and thus help prevent the recurrence of abuse and provide safer and more permanent care environments.

Separate analyses for internalizing and externalizing problems were conducted in this study, and the effects of caregiver and peer relationships, as well as causal relations between relationship quality and behavior problems, have been examined separately for internalizing and externalizing problems. Further study can look at how internalizing and externalizing behavior problems interact with each other (as well as with caregiver and peer relationships) and lead to certain results.

The foster care experience, peer interactions, and the persistence of internalizing and externalizing problems may all differ by gender. It is recommended that future studies investigate gender differences in placement move patterns as well as in behavioral

functioning and relationship quality.

The current study focused on adolescents. Future studies could assess developmental trajectories of children in different developmental stages. Out-of-home placement may have different effects on younger children, and their attachment to their biological parents may differ from the attachment of older children. Research from the age-specific approach can help provide developmentally relevant services to children in child welfare.

This study included all youth regardless of whether their CBCL scores were in the clinical range or not. Youth in the clinical range may develop different trajectories over time from those not in the clinical range. In addition, factors that may affect adolescents' long-term functioning may differ between these two groups. Future studies focusing on youth in the clinical range of behavior problems will provide information that can help policymakers and practitioners create more effective interventions, particularly for the most vulnerable youths in this already at-risk group of children.

The current study investigated one dimension of youth development: internalizing (social withdrawal, somatic complaints and anxiety and depression) and externalizing behavioral functioning (delinquency and aggression) as measured by the CBCL. Future studies would do well to closely examine subareas of internalizing and externalizing problems. In addition, there are other important dimensions of development, such as academic achievement and psychological well-being. Examining these outcomes will provide a more comprehensive understanding of in the child welfare system.

Finally, this study did not control for factors that may be associated with youths' behavior outcomes. The results from the current study indicated that a portion of the

variance in youth behavior problems was not explained by the youths' relationship with caregivers and peers. Additional studies are necessary to further investigate what factors may contribute to youths' behavioral problems independent of, or in interaction with, caregiver- and peer relationships.

References

- Achenbach, T. M. (1991). *Manual for the child behavior checklist / 4-18 and 1991 profile*. Burlington VT: University of Vermont. Department of psychiatry.
- Ainsworth, M. D. S. (1967). *Infancy in Uganda; infant care and the growth of love*. Baltimore: Johns Hopkins Press.
- Ainsworth, M. D. S., Blehar, M.C., Waters, E., & Wall, S. (1978). *Patterns of attachment: A psychological study of the strange situation*. Hillsdale, N.J.: Lawrence Erlbaum Associates.
- Allen, J. P., Marsh, P., McFarland, C., McElhaney, K. B., Land, D. J., Jodl, K. M., & Peck, S. (2002). Attachment and autonomy as predictors of the development of social skills and delinquency during midadolescence. *Journal of Consulting and Clinical Psychology, 70*(1), 56-66.
- Allen, J. P., Porter, M. R., McFarland, F. C., & Marsh, P. (2005). The two faces of adolescents' success with peers: Adolescent popularity, social adaptation, and deviant behavior. *Child Development, 76*(3), 747-760.
- Asher, S. R., & Wheeler, V. A. (1985). Children's loneliness: A comparison of rejected and neglected peer status. *Journal of Consulting and Clinical Psychology, 53*(4), 500-505.
- Barth, R.P., Green, S.G., Guo, S., & McCrae, J.S. (2007). Kinship care and nonkinship foster care: Informing the new debate. In Haskins, R., Wulczyn, F., & Webb, M.B. (Eds.), *Child protection: Using research to improve policy and practice* (pp. 187-206). Washington D.C.: Brookings Institution Press.
- Benedict, M. I., Zuravin, S., & Stallings, R. Y. (1996). Adult functioning of children who lived in kin versus nonrelative family foster homes. *Child Welfare, 75*(5), 529-549.
- Berlin, L. J., & Cassidy, J. (1999). Relations among relationships: Contributions from attachment theory and research. In J. Cassidy, & P. R. Shaver (Eds.), *Handbook of attachment : Theory, research, and clinical applications* (pp. 688-712). New York: Guilford Press.
- Bohlin, G., Hagekull, B., & Rydell, A. (2000). Attachment and Social Functioning: A Longitudinal Study from Infancy to Middle Childhood. *Social Development, 9*(1), 24-39.
- Bolger, K. E., Patterson, C. J., & Kupersmidt, J. B. (1998). Peer relationships and self-esteem among children who have been maltreated. *Child Development, 69*(4), 1171-1197.

- Bolger, K. E., & Patterson, C. J. (2001). Developmental pathways from child maltreatment to peer rejection. *Child Development, 72*(2), 549-568.
- Bollen, K.A., & Curran, P.J. (2006). *Latent Curve Models: A structural equation perspective*. Hoboken, NJ: Wiley.
- Bowlby, J. (1973). *Attachment and loss, Vol. 2: Separation*. New York: Basic Books.
- Bowlby, J. (1969). *Attachment and loss, Vol. 1: Attachment*. New York: Basic Books.
- Bowlby, J. (1979). *The making & breaking of affectional bonds*. London: Tavistock Publications.
- Bowlby, J. (1980). *Attachment and loss, Vol. 3: Loss*. New York: Basic Books.
- Buehler, C., Orme, J. G., Post, J., & Patterson, D. A. (2000). The long-term correlates of family foster care. *Children and Youth Services Review, 22*(8), 595-625.
- Burns, B. J., Phillips, S. D., Wagner, H. R., Barth, R. P., Kolko, D. J., Campbell, Y., et al. (2004). Mental health need and access to mental health services by youths involved with child welfare: A national survey. *Journal of the American Academy of Child and Adolescent Psychiatry, 43*(8), 960-970.
- Carlson, V. (1989). Disorganized/Disoriented attachment relationships in maltreated infants. *Developmental Psychology, 25*(4), 525-531.
- Carlson, E. A. (1998). A prospective longitudinal study of attachment disorganization/disorientation. *Child Development, 69*(4), 1107-1128.
- Casanueva, C., Martin, S.L., Runyan, D.K., Barth, R.P., & Bradely, R.H. (2008). Parenting services for mothers involved with child protective services: Do they change maternal parenting and spanking behaviors with young children? *Child and Youth Services Review, 30*(8), 861-878.
- Chapman, M., Wall, A., & Barth, R. (2004). Children's voices: The perceptions of children in foster care. *American Journal of Orthopsychiatry, 74*(3), 293-304.
- Child Welfare Information Gateway. (2008). *How the child welfare system works*. Retrieved from July, 2008 from www.childwelfare.gov/pubs/factsheets/cpswork.cfm
- Cicchetti, D., & Garnezy, N. (1993). Prospects and promises in the study of resilience. *Development and Psychopathology, 5*(4), 497-502.
- Cicchetti, D., Rogosch, F. A., Lynch, M., & Holt, K. D. (1993). Resilience in maltreated children: Processes leading to adaptive outcome. *Development and Psychopathology, 5*(4), 629-647.

- Cicchetti, D., & Rogosch, F. A. (2002). A developmental psychopathology perspective on adolescence. *Journal of Consulting and Clinical Psychology, 70*(1), 6-20.
- Cicchetti, D., & Toth, S. L. (2000). Developmental processes in maltreated children. *Nebraska Symposium on Motivation, 46*, 85-160.
- Cicchetti, D., & Carlson, V. (1989). *Child maltreatment : Theory and research on the causes and consequences of child abuse and neglect*. Cambridge; New York: Cambridge University Press.
- Clausen, J. M., Landsverk, J., Ganger, W., Chadwick, D., & Litrownik, A. (1998). Mental health problems of children in foster care. *Journal of Child and Family Studies, 7*(3), 283-296.
- Cohen, P., Brown, J., & Smaile, E. (2001). Child abuse and neglect and the development of mental disorders in the general population. *Development and Psychopathology, 13*(4), 981-999.
- Cole, D. A., & Maxwell, S. E. (2003). Testing mediational models with longitudinal data: Questions and tips in the use of structural equation modeling. *Journal of Abnormal Psychology, 112*(4), 558-577.
- Connell, J. P. (1990). Context, self and action: A motivational analysis of self-system processes across the life-span. In D. Cicchetti, & M. Beeghly (Eds.), *The self in transition* (pp. 61-97). Chicago: University of Chicago Press.
- Cook-Fong, S.K. (2000). The adult well-being of individuals reared in family foster care placement. *Child Youth Forum, 29*, 7-25.
- Costello, E.J., Farmer, E.M.Z., Angold, A., Burns, B.J., Erkanli, A. (1997), Psychiatric disorders among American Indian and white youth in Appalachia: the Great Smoky Mountains Study. *American Journal of Public Health, 87*, 827-832.
- Criss, M. M., Pettit, G. S., Bates, J. E., Dodge, K. A., & Lapp, A. L. (2002). Family adversity, positive peer relationships, and children's externalizing behavior: A longitudinal perspective on risk and resilience. *Child Development, 73*(4), 1220-1237.
- Crittenden, P. M., & Ainsworth, M. D. S. (1989). Child maltreatment and attachment theory. In D. Cicchetti, & Carlson, V. (Eds.), *Child maltreatment : Theory and research on the causes and consequences of child abuse and neglect* (pp. 432-463). Cambridge; New York: Cambridge University Press.
- Curran, P. J., Harford, T. C., & Muthen, B. O. (1996). The relation between heavy alcohol use and bar patronage: A latent growth model. *Journal of Studies on Alcohol, 57*(4), 410-418.

- Darwish, D., Esquivel, G.B., Houtz, J.C., & Alfonso, V.C. (2001). Play and social skills in maltreated and nonmaltreated preschoolers during peer interactions. *Child Abuse & Neglect*, 25, 13-31.
- Deater-Deckard, K. (2001). Annotation: Recent research examining the role of peer relationships in the development of psychopathology. *Journal of Child Psychology and Psychiatry*, 42(5), 565-579.
- Depanfilis, D. (2005). Child protective services. In G. P. Mallon, & P. M. Hess (Eds.), *Child welfare for the 21st century* (pp. 290-301). New York: Columbia University Press.
- Dodge, K. A., Pettit, G. S., & Bates, J. E. (1994). Effects of physical maltreatment on the development of peer relations. *Development and Psychopathology*, 6(10), 43-56.
- Dodge, K. A., & Pettit, G. S. (2003). A biopsychosocial model of the development of chronic conduct problems in adolescence. *Developmental Psychology*, 39(2), 349-371.
- Dowd, K., Kinsey, S., Wheelless, S., Thissen, R., Richardson, J., Suresh, R., et al. (2007). *National survey of child and adolescent well-being (NSCAW): Combined waves 1-5 data file User's manual*. National Data Archive on Child Abuse and Neglect.
- Doyle, J. J. (2007). *Child protection and child outcomes: Measuring the effects of foster care*. Retrieved September, 2007 from www.mit.edu/~jjdoyle/doyle_fosterlt_march07_aer.pdf
- Dozier, M., Stovall, K. C., Albus, K. E., & Bates, B. (2001). Attachment for infants in foster care: The role of caregiver state of mind. *Child Development*, 72(5), 1467-1477.
- Fanshel, D., & Shinn, E. B. (1978). *Children in foster care: A longitudinal investigation*. New York: Columbia University Press.
- Farmer, E. M. Z., Burns, B. J., Chapman, M. V., Phillips, S. D., Angold, A., & Costello, E. J. (2001). Use of mental health services by youth in contact with social services. *Social Service Review*, 75(4), 605-624.
- Farruggia, S. P., Greenberger, E., Chen, C., & Heckhausen, J. (2006). Perceived social environment and adolescents' well-being and adjustment: Comparing a foster care sample with a matched sample. *Journal of Youth and Adolescence*, 35(3), 330-339.
- Field, T. (1996). Attachment and separation in young children. *Annual Review of Psychology*, 47, 541-561.

- Fraley, R. C., & Davis, K. E. (1997). Attachment formation and transfer in young adults' close friendships and romantic relationships. *Personal Relationships, 4*(2), 131-144.
- Fraser, M. K., & Terzian, M. A. (2005). Risk and resilience in child development. In G. P. Mallon, & P. M. Hess (Eds.), *Child welfare for the 21st century* (pp. 55-71). New York: Columbia University Press.
- Furrer, C., & Skinner, E. (2003). Sense of relatedness as a factor in children's academic engagement and performance. *Journal of Educational Psychology, 95*(1), 148-162.
- Garnezy, N. (1970). Process and reactive schizophrenia: Some conceptions and issues. *Schizophrenia Bulletin, 2*, 30-74.
- Garnezy, N. (1974). The study of competence in children at risk for severe psychopathology. In E. J. Anthoy, & C. Koupernik (Eds.), *The child in his family: Children at psychiatric risk, Vol. 3.* (pp. 77-97). New York: Wiley.
- Garnezy, N., Masten, A. S., & Tellegen, A. (1984). The study of stress and competence in children: A building block for developmental psychopathology. *Child Development, 55*(1), 97-111.
- Goldstein, S. E., Davis-Kean, P. E., & Eccles, J. S. (2005). Parents, peers, and problem behavior: A longitudinal investigation of the impact of relationship perceptions and characteristics on the development of adolescent problem behavior. *Developmental Psychology, 41*(2), 401-413.
- Halfon, N., Berkowitz, G., & Klee, L. (1992). Mental health service utilization by children in foster care in california. *Pediatrics, 89*(6), 1238-1244.
- Harman, J. S., Childs, G. E., & Kelleher, K. J. (2000). Mental health care utilization and expenditures by children in foster care. *Archives of Pediatrics & Adolescent Medicine, 154*, 1114-1117.
- Harris, J.R. (1998). *The nurture assumption: Why children turn out the way they do.* New York: The Free Press.
- Haskett, M. E., & Kistner, J. A. (1991). Social interactions and peer perceptions of young physically abused children. *Child Development, 62*(5), 979-990.
- Haskett, M. E., Nears, K., Ward, C. S., & McPherson, A. V. (2006). Diversity in adjustment of maltreated children: Factors associated with resilient functioning. *Clinical Psychology Review, 26*(6), 796-812.
- Heflinger, C. A., Simpkins, C. G., & Combs-Orme, T. (2000). Using the CBCL to determine the clinical status of children in state custody. *Children and Youth Services Review, 22*(1), 55-73.

- Hofstra, M.B., Van der Ende, J., & Verhulst, F.C. (2000). Continuity and change of psychopathology from childhood into adulthood: A 14-year follow-up study. *Journal of the American Academy of Child and Adolescent Psychiatry*, 39, 850-858.
- Holmbeck, G. N., & Kendall, P. C. (2002). Introduction to the special section on clinical adolescent psychology: Developmental psychopathology and treatment. *Journal of Consulting and Clinical Psychology*, 70(1), 3-5.
- Horwitz, S. M. C., Balestracci, K. M. B., & Simms, M. D. (2001). Foster care placement improves children's functioning. *Archives of Pediatrics and Adolescent Medicine*, 155(11), 1255-1260.
- Horwitz, A. V., Widom, C. S., McLaughlin, J., & White, H. R. (2001). The impact of childhood abuse and neglect on adult mental health: A prospective study. *Journal of Health and Social Behavior*, 42, 184-201.
- Howes, C. (2008). Attachment relationships in the context of multiple caregivers. In J. Cassidy, & P. R. Shaver (Eds.), *Handbook of attachment: Theory, research, and clinical applications* (2nd ed., pp. 317-332). New York: Guilford Press.
- Hulsey, T. C., & White, R. (1989). Family characteristics and measures of behavior in foster and nonfoster children. *American Journal of Orthopsychiatry*, 59, 502-509.
- Hurlburt, M.S., Barth, R.P., Leslie, L.K., Landsverk, J.A., & McCrae, J. (2007). Building on strengths: Current status and Opportunities for improvement of parent training for families in child welfare. In Haskins, R., Wulczyn, F., & Webb, M.B. (Eds.), *Child protection: Using research to improve policy and practice* (pp. 81-106). Washington D.C.: Brookings Institution Press.
- Jonson-Reid, M., Drake, B., Kim, J., Porterfield, S., & Han, L. (2004). A prospective analysis of the relationship between reported child maltreatment and special education eligibility among poor children. *Child Maltreatment*, 9(4), 382-394.
- Kaplan, S. J., Pelcovitz, D., & Labruna, V. (1999). Child and adolescent abuse and neglect research: A review of the past 10 years. part I: Physical and emotional abuse and neglect. *Journal of the American Academy of Child and Adolescent Psychiatry*, 38(10), 1214-1222.
- Keiley, M. K., Howe, T. R., Dodge, K. A., Bates, J. E., & Petti, G. S. (2001). The timing of child physical maltreatment: A cross-domain growth analysis of impact on adolescent externalizing and internalizing problems. *Development and Psychopathology*, 13(4), 891-912.
- Keller, T. E., Wetherbee, K., Le Prohn, N. S., Payne, V., Sim, K., & Lamont, E. R. (2001). Competencies and problem behaviors of children in family foster care:

- Variations by kinship placement status and race. *Children and Youth Services Review*, 23(12), 915-940.
- Kerker, B. D., & Dore, M. M. (2006). Mental health needs and treatment of foster youth: Barriers and opportunities. *American Journal of Orthopsychiatry*, 76(1), 138-147.
- Kim, J., & Cicchetti, D. (2004). A longitudinal study of child maltreatment, mother-child relationship quality and maladjustment: The role of self-esteem and social competence. *Journal of Abnormal Child Psychology*, 32(4), 341-354.
- Kim, J., & Cicchetti, D. (2006). Longitudinal trajectories of self-system processes and depressive symptoms among maltreated and nonmaltreated children. *Child Maltreatment*, 77(3), 624-639.
- Kimberlin, S.E., Anthony, E.K., & Austin, M.J. (2009). Re-entering foster care: Trends, evidence, and implications. *Child and Youth Services Review*, 31, 471-481.
- Kortenkamp, K., & Ehrle, J. (2002). *The well-being of children involved with the child welfare system: A national overview*. The Urban Institute. Retrieved March, 2008 from www.urban.org/UploadedPDF/310413_anf_b43.pdf
- Ladd, G. W., & Price, J. M. (1987). Predicting children's social and school adjustment following the transition from preschool to kindergarten. *Child Development*, 58(5), 1168-1189.
- Ladd, G. W., & Troop-Gordon, W. (2003). The role of chronic peer difficulties in the development of children's psychological adjustment problems. *Child Development*, 74(5), 1344-1367.
- Laible, D. J., Carlo, G., & Raffaelli, M. (2000). The differential relations of parent and peer attachment to adolescent adjustment. *Journal of Youth and Adolescence*, 29(1), 45-59.
- Lamb, M. E., Gaensbauer, T. J., Malkin, C. M., & Schultz, L. A. (1985). The effects of child maltreatment on security of infant-adult attachment. *Infant Behavior & Development*, 8(1), 35-45.
- Lansford, J. E., Malone, P. S., Stevens, K. I., Dodge, K. A., Bates, J. E., & Pettit, G. S. (2006). Developmental trajectories of externalizing and internalizing behaviors: Factors underlying resilience in physically abused children. *Development and Psychopathology*, 18(1), 35-55.
- Larson, R., & Richards, M. H. (1991). Daily companionship in late childhood and early adolescence: Changing developmental contexts. *Child Development*, 62(2), 284-300.

- Lee, L. C. (1975). Toward a cognitive theory of interpersonal development: Importance of peers. In M. Lewis, & L. A. Rosenblum (Eds.), *Friendship and peer relations*. New York: Wiley.
- Leslie, L. K., Hurlburt, M. S., Landsverk, J., Barth, R., & Slymen, D. J. (2004). Outpatient mental health services for children in foster care: A national perspective. *Child Abuse & Neglect, 28*, 697-712.
- Lewis, M., & Rosenblum, L. A. (1975). *Friendship and peer relations*. New York: Wiley.
- Lieberman, A. F. (1977). Preschoolers' competence with a peer: Relations with attachment and peer experience. *Child Development, 48*(4), 1277-1287.
- Lopez, C., & Dubois, D. L. (2005). Peer victimization and rejection: Investigation of an integrative model of effects on emotional, behavioral, and academic adjustment in early adolescence. *Journal of Clinical Child and Adolescent Psychology, 34*(1), 25-36.
- Luthar, S. S., Cicchetti, D., & Becker, B. (2000). The construct of resilience: A critical evaluation and guidelines for future work. *Child Development, 71*(3), 543-562.
- Luthar, S. S., & Cushing, G. (1999). Measurement issues in the empirical study of resilience. In M. D. Glantz, & J. L. Johnson (Eds.), *Resilience and development: Positive life adaptations* (pp. 129-160). New York: Kluwer Academic/Plenum Publishers.
- Lynch, M., & Cicchetti, D. (1991). Patterns of relatedness in maltreated and nonmaltreated children: Connections among multiple representational models. *Development and Psychopathology, 3*(2), 207-226.
- Lyons-Ruth, K., & Jacobvitz, D. (2008). Attachment disorganization: Unresolved loss, relational violence, and lapses in behavioral and attentional strategies. In P. Shaver, & J. Cassidy (Eds.), *Handbook of attachment: Theory, research, and clinical applications* (2nd ed., pp. 666-697). New York: Guilford Press.
- Main, M., & Hesse, E. (1990). Parents' unresolved traumatic experiences are related to infant disorganized attachment status: Is frightened and/or frightening parental behavior the linking mechanism. In M. T. Greenberg, D. Cicchetti & M. E. Cummings (Eds.), *Attachment in the preschool years: Theory, research, and intervention* (pp. 161-182). Chicago: University of Chicago Press.
- Main, M., & Solomon, J. (1986). Discovery of a new, insecure-disorganized/disoriented attachment pattern. In T. Brazelton, & M. Youngman (Eds.), *Affective development in infancy* (pp. 95-124). Norwood, NJ: Ablex.

- Mallon, G. P., & Hess, P. M. (2005). *Child Welfare for the 21st Century: A Handbook of Practices, Policies, and Programs*. New York: Columbia University Press.
- Manly, J. T., Cicchetti, D., & Barnett, D. (1994). The impact of subtype, frequency, chronicity, and severity of child maltreatment on social competence and behavior problems. *Development and Psychopathology, 6*(1), 121-143.
- Manly, J. T., Kim, J. E., Rogosch, F. A., & Cicchetti, D. (2001). Dimensions of child maltreatment and children's adjustment: contributions of developmental timing and subtype. *Development and Psychopathology, 13*(4), 759-782.
- Marcus, R. F. (1991). The attachments of children in foster care. *Genetic, Social & General Psychology Monographs, 117*(4), 365-394.
- Margolin, G., & Gordis, E.B. (2000). The effects of family and community violence on children. *Annual Reviews in Psychology, 51*(1), 445-479.
- Martens, M.P., & Haase, R.F. (2006). Advanced applications of structural equation modeling in counseling psychology research. *The Counseling Psychologist, 34*(6), 878-911.
- Masten, A. S. (2001). Ordinary magic. resilience processes in development. *The American Psychologist, 56*(3), 227-238.
- Masten, A. S. (2005). Peer relationships and psychopathology in developmental perspective: Reflections on progress and promise. *Journal of Clinical Child and Adolescent Psychology, 34*(1), 87-92.
- McCrae, J.S. (2009). Emotional and behavioral problems reported in child welfare over 3 years. *Journal of Emotional and Behavioral Disorders, 17*(1), 17-28.
- McGloin, J. M., & Widom, C. S. (2001). Resilience among abused and neglected children grown up. *Development and Psychopathology, 13*(4), 1021-1038.
- McIntyre, A., & Keesler, T. Y. (1986). Psychological disorders among foster children. *Journal of Clinical Child Psychology, 15*(4), 297-303.
- McMillen, J. C., Zima, B. T., Scott, L. D., Auslander, W. F., Munson, M. R., Ollie, M. T., & Spitznagel, E. L. (2005). Prevalence of psychiatric disorders among older youths in the foster care system. *Journal of the American Academy of Child & Adolescent Psychiatry, 44*(1), 88-95.
- Milan, S. E., & Pinderhughes, E. E. (2000). Factors influencing maltreated children's early adjustment in foster care. *Development and Psychopathology, 12*(1), 63-81.

- Moran, P. B., & Eckenrode, J. (1992). Protective personality characteristics among adolescent victims of maltreatment. *Child Abuse & Neglect, 16*(5), 743-754.
- Muthén, L.K., & Muthén, B.O. (2008). *MPlus User's Guide (5th ed.)*. Los Angeles, CA: Muthén and Muthén.
- Newton, R. R., Litrownik, A. J., & Landsverk, J. A. (2000). Children and youth in foster care: Distinguishing the relationship between problem behaviors and number of placements. *Child Abuse & Neglect, 24*(10), 1363-1374.
- Noom, M. J., Dekovic, M., & Meeus, W. H. (1999). Autonomy, attachment and psychosocial adjustment during adolescence: A double-edged sword? *Journal of Adolescence, 22*(6), 771-783.
- Ollendick, T.H., Grills, A.E., King, N.J. (2001). Applying developmental theory to the assessment and treatment of childhood disorders: Does it make a difference? *Clinical Psychology and psychotherapy, 8*, 304-314.
- Orme, J. G., & Buehler, C. (2001). Foster family characteristics and behavioral and emotional problems of foster children: A narrative review. *Family Relations, 50*(1), 3-15.
- Paikoff, R. L., & Brooks-Gunn, J. (1991). Do parent-child relationships change during puberty? *Psychological Bulletin, 110*(1), 47-66.
- Parker, J., & Asher, S. R. (1987). Peer acceptance and later personal adjustment: Are low-accepted children at risk? *Psychological Bulletin, 102*, 357-389.
- Parker, J. G., & Asher, S. R. (1993). Friendship and friendship quality in middle childhood: Links with peer group acceptance and feelings of loneliness and social dissatisfaction. *Developmental Psychology, 29*(4), 611-621.
- Parker, J. G., Rubin, K. H., Erath, S. A., Wojslawowicz, J. C., & Buskirk, A. A. (2006). Peer relationships, child development, and adjustment: A developmental psychopathology perspective. In D. Cicchetti & D. J. Cohen (Eds.), *Developmental psychopathology: Vol. 1. Theory and method* (2nd ed., pp. 419–493). Hoboken, N.J.: Wiley.
- Pilowsky, D. J., & Wu, L. (2006). Psychiatric symptoms and substance use disorders in a nationally representative sample of American adolescents involved with foster care. *Journal of Adolescent Health, 38*, 351-358.
- Price, J.M., & Brew, V. (1998). Peer relationships of foster children: developmental and mental health service implications. *Journal of Applied Developmental Psychology, 19*(2), 199-218.

- Putnam, F.W. (2003). Ten-year research update review: Child sexual abuse. *Journal of the American Academy of Child & Adolescent Psychiatry*, 42(3), 269-278.
- Rosenthal, J.A., & Curiel, H.F. (2006). Modeling behavioral problems of children in the child welfare system: Caregiver, youth, and teacher perceptions. *Children and Youth Services Review*, 28, 1391-1408.
- Runyan, D. K., & Gould, C. L. (1985). Foster care for child maltreatment: Impact on delinquent behavior. *Pediatrics*, 75(3), 562-568.
- Rutter, M. (1987). Psychosocial resilience and protective mechanisms. *The American Journal of Orthopsychiatry*, 57(3), 316-331.
- Ryan, A.M. (2001). The peer group as a context for the development of young adolescent motivation and achievement. *Child Development*, 72(4), 1135-1150.
- Salzinger, S., Feldman, R. S., Hammer, M., & Rosario, M. (1993). The effects of physical abuse on children's social relationships. *Child Development*, 64(1), 169-187.
- Salzinger, S., Rosario, M., & Feldman, R. S. (2007). Physical child abuse and adolescent violent delinquency: The mediating and moderating roles of personal relationships. *Child Maltreatment*, 12(3), 208-219.
- Scannapieco, M., & Connell-Carrick, K. (2005). *Understanding Child Maltreatment: An Ecological and Developmental Perspective*. New York: Oxford University press.
- Shaw, D. S., Owens, E. B., Vondra, J. I., Keenan, K., & Winslow, E. B. (1996). Early risk factors and pathways in the development of early disruptive behavior problems. *Development and Psychopathology*, 8(4), 679-699.
- Shields, A., Ryan, R. M., & Cicchetti, D. (2001). Narrative representations of caregivers and emotion dysregulation as predictors of maltreated children's rejection by peers. *Developmental Psychology*, 37(3), 321-337.
- Simmel, C., Barth, R.P., & Brooks, D. (2006). Adopted foster youths' psychosocial functioning: A longitudinal perspective. *Child and Family Social Work*, 12, 336-348.
- Simmel, C., Lee, I., & Kim, S. Multiple Perspectives on Foster Youths' Mental Health Functioning: Diagnostic Agreement and Likelihood of Receiving Services. Manuscript submitted for publication.
- Simms, M. D., Dubowitz, H., & Szilagyi, M. A. (2000). Health care needs of children in the foster care system. *Pediatrics*, 106, 909-918.

- Simons-Morton, B., Haynie, D. L., Crump, A. D., Eitel, P., & Saylor, K. E. (2001). Peer and parent influence on smoking and drinking among early adolescents. *Health Education & Behavior, 28*(1), 95-107.
- Smith, C., & Thornberry, T.P. (1995). The relationship between childhood maltreatment and adolescent involvement in delinquency. *Criminology, 33*(4), 451-481.
- Sroufe, L. A., & Fleeson, J. (1986). Attachment and the construction of relationships. In W. Hartup, & Z. Rubin (Eds.), *Relationships and development* (pp. 51-71). Hillsdale, NJ: Erlbaum.
- Stahmer, A. C., Leslie, L. K., Hurlburt, M., Barth, R. P., Webb, M. B., Landsverk, J., Zhang, J. (2005). Developmental and behavioral needs and service use for young children in child welfare. *Pediatrics, 116*(4), 891-900.
- Sternberg, K. J., Lamb, M. E., Guterman, E., Abbott, C. B., & Dawud-Noursi, S. (2005). Adolescents' perceptions of attachments to their mothers and fathers in families with histories of domestic violence: A longitudinal perspective. *Child Abuse & Neglect, 29*(8), 853-869.
- Stouthamer-Loeber, M., Loeber, R., Homish, D.L., & Wei, E. (2001). Maltreatment of boys and the development of disruptive and delinquent behavior. *Development and Psychopathology, 13*(4), 941-955.
- Taussig, H. N. (2002). Risk behaviors in maltreated youth placed in foster care: A longitudinal study of protective and vulnerability factors. *Child Abuse & Neglect, 26*(11), 1179-1199.
- Taussig, H. N., Clyman, R. B., & Landsverk, J. (2001). Children who return home from foster care: A 6-year prospective study of behavioral health outcomes in adolescence. *Pediatrics, 108*(1), E10.
- Terling, T. (1999). The efficacy of family reunification practices: Reentry rates and correlates of reentry for abused and neglected children reunited with their families. *Child Abuse & Neglect, 23*(12), 1359-1370.
- Thornberry, T.P., Ireland, T.O., & Smith, C.A. (2001). The importance of timing: The varying impact of childhood and adolescent maltreatment on multiple problem outcomes. *Development and psychopathology, 13*(4), 957-979.
- Toth, S. L., & Cicchetti, D. (1996a). The impact of relatedness with mother on school functioning in maltreated children. *Journal of School Psychology, 34*(3), 247-266.
- Toth, S. L., & Cicchetti, D. (1996b). Patterns of relatedness, depressive symptomatology, and perceived competence in maltreated children. *Journal of Consulting and Clinical Psychology, 64*(1), 32-41.

- Toth, S. L., & Cicchetti, D. (2006). Promises and possibilities: The application of research in the area of child maltreatment to policies and practices. *Journal of Social Issues, 62*(4), 863-880.
- Trupin, E. W., Tarico, V. S., Low, B. P., Jemelka, R., & McClellan, J. (1993). Children on child protective service caseloads: Prevalence and nature of serious emotional disturbance. *Child Abuse & Neglect, 17*(3), 345-355.
- U.S. Department of Health and Human Services, Administration on Children, Youth and Families. (2008a). *Child maltreatment 2006*. Washington, D.C.: Government Printing Office. Retrieved July, 2008 from www.acf.hhs.gov/programs/cb/pubs/cm06/index.htm
- U.S. Department of Health and Human Services, Administration on Children, Youth, and Families. (2008b). *The AFCARS report: Preliminary FY 2006 estimates as of January 2008 (14)*. Retrieved July, 2008 from www.acf.hhs.gov/programs/cb/stats_research/afcars/tar/report14.htm
- Urquiza, A. J., Wirtz, S. J., Peterson, M. S., & Singer, V. A. (1994). Screening and evaluating abused and neglected children entering protective custody. *Child Welfare, 73*(2), 155-171.
- Veltman, M.W.M., & Browne, K.D. (2001). Three decades of child maltreatment research: Implications for the School Years. *Trauma, Violence, & Abuse, 2*(3), 215-239.
- Visser, J.H., Van der Ende, J., Koot, H.M., & Verhulst, F.C. (2003). Predicting change in psychopathology in youth referred to mental health services in childhood or adolescence. *Journal of Child Psychology and Psychiatry, 44*(4), 509-519.
- Vitaro, F., Pedersen, S., & Brendgen, M. (2007). Children's disruptiveness, peer rejection, friends' deviancy, and delinquent behaviors: A process-oriented approach. *Development and Psychopathology, 19*(2), 433-453.
- Wald, M., Carlsmith, J. M., & Leiderman, P. H. (1988). *Protecting abused and neglected children*. Stanford, California: Stanford University Press.
- Wall, A. E. (2004). *Problem Behaviors in Maltreated Children and Youth*. Unpublished doctoral dissertation, University of North Carolina, Chapel Hill.
- Wall, A. E., & Barth, R. P. (2005). Aggressive and delinquent behavior of maltreated adolescents: Risk factors and gender differences. *Stress, Trauma, and Crisis: An International Journal, 8*(1), 1-24.
- Wentzel, K. R. (1991). Relations between social competence and academic achievement in early adolescence. *Child Development, 62*(5), 1066-1078.

- Wentzel, K. R., & Caldwell, K. (1997). Friendships, peer acceptance, and group membership: Relations to academic achievement in middle school. *Child Development, 68*(6), 1198-1209.
- Werner, E. E. (1993). Risk, resilience, and recovery: Perspectives from the kauai longitudinal study. *Development and Psychopathology, 5*(4), 503-515.
- Werner, E. E. (1995). Resilience in development. *Current Directions in Psychological Science, 4*(3), 81-85.
- Werner, E. E., French, F. E., & Bierman, J. M. (1971). *The children of kauai: A longitudinal study from the prenatal period to age ten*. Honolulu: University of Hawaii Press.
- Werner, E. E., & Smith, R. S. (1977). *Kauai's children come of age*. Honolulu: University Press of Hawaii.
- Windle, M. (1999). Critical conceptual and measurement issues in the study of resilience. In M. D. Glantz, & J. L. Johnson (Eds.), *Resilience and development: Positive life adaptations* (pp. 161-176). New York: Kluwer Academic/Plenum Publishers.
- Windle, M. (2000). Parental, sibling, and peer influences on adolescent substance use and alcohol problems. *Applied Developmental Science, 4*(2), 98-110.
- Wood, M. D., Read, J. P., Mitchell, R. E., & Brand, N. H. (2004). Do parents still matter? Parent and peer influences on alcohol involvement among recent high school graduates. *Psychology of Addictive Behaviors, 18*(1), 19-30.
- Wulczyn, F., Barth, R. P., Yuan, Y. T., Jones Harden, B., & Landsverk, J. (2005). *Beyond common sense*. New Brunswick: Aldine Transaction.
- Zima, B. T., Bussing, R., Freeman, S., Yang, X., Belin, T. R., & Forness, S. R. (2000). Behavior problems, academic skill delays and school failure among school-aged children in foster care: Their relationship to placement characteristics. *Journal of Child and Family Studies, 9*(1), 87-103.

Curriculum Vitae

INSEON LEE

- 1997 BA, English Language and Literature, Yonsei University, Korea
- 2004 MSW, School of Social Work, Yonsei University, Korea
- 2009 Ph.D., School of Social Work, Rutgers, The State University of New Jersey
- 2001-2003 Research Assistant for Professor Ick-seop Lee, Center for Social Welfare Research, Yonsei University, Korea
- 2003 Course Instructor, *Social Welfare with the Disabled*
Sahmyook Nursing & Health College, Korea
- 2004-2005 Research Assistant at Seoul Development Institute, Korea
- 2006–2008 STATA Lab Instructor & Teaching Assistant, *Advanced Statistics I, II*
School of Social Work, Rutgers, The State University of New Jersey
- 2008 Course Instructor, *Methods of Social Work Research I* (MSW course)
School of Social Work, Rutgers, The State University of New Jersey
- 2007-Present Research Associate for Professor Cassandra Simmel
School of Social Work, Rutgers, The State University of New Jersey

Publication

- Huang, C. C. & Lee, I. (2008). The First-Three Years of Parenting: Evidence from the Fragile Families and Child Well-being Study. *Children and Youth Services Review, 30, 1447-1457.*