

© 2019

Ümit Atlamaz

ALL RIGHTS RESERVED

AGREEMENT, CASE, AND NOMINAL LICENSING

By

ÜMIT ATLAMAZ

A dissertation submitted to the  
School of Graduate Studies  
Rutgers, The State University of New Jersey

In partial fulfillment of the requirements

For the degree of  
Doctor of Philosophy  
Graduate Program in Linguistics

Written under the direction of

Mark C. Baker

And approved by

---

---

---

---

New Brunswick, New Jersey

May, 2019

## ABSTRACT OF THE DISSERTATION

### Agreement, Case, and Nominal Licensing

By ÜMİT ATLAMAZ

Dissertation Director:

Mark C. Baker

This dissertation examines the interaction of agreement and case by investigating case-sensitivity of agreement and differential object marking. I develop a theory of agreement and case where surface agreement and surface case are the outputs of a set of distinct operations distributed across different modules of grammar and ordered in a certain way.

The first part of the dissertation investigates case-sensitivity of agreement. I show that there are three types of languages with respect to case-sensitivity: 1) languages where case blocks agreement totally, 2) languages where case blocks agreement partially, and 3) languages where case does not block agreement at all. I propose that case-sensitivity of agreement is a matter of Relativized Minimality (Rizzi 1990). In languages where agreement is blocked by case (partially or totally), the agreement probe is specified for an underspecified [+nominal] feature and it agrees with the case phrase (KP) (Bittner and Hale 1996; Lamontagne and Travis 1986), which intervenes between the probe and any of the person, number, and gender features on the goal. I show that in languages where case blocks agreement fusion of number and case feeds agreement. I develop a theory of two-step agreement (Arregi and Nevins 2012; Bhatt and Walkow 2013; Marušič, Nevins, and Badecker 2015) where the first agreement operation (Agree-Link) establishes an agreement relation between a probe and a goal in the syntax by adding a pointer to the probe whereas the second agreement

operation (Agree-Copy) dereferences the pointer by replacing it with the actual values of person, number and gender features. Crucially, Agree-Copy applies after Fusion (Halle and Marantz 1993), a post syntactic operation that takes two adjacent heads and turns them into a single head without any internal structure. In languages where case does not block agreement at all, agreement probes are specified for person, number, and gender features and they are introduced separately. This enables them to skip over the irrelevant syntactic objects and establish full agreement with case marked nominals via Relativized Probing (Nevins 2011; Preminger 2014).

The second part of the dissertation explores the interaction of case and agreement by investigating differential object marking. I show that differential object making is not a uniform phenomenon and in some languages differential object marking is the result of Dependent Case assignment (Baker 2015; Marantz 1984) while in others, differential object marking is a result of nominal licensing via agreement (Barány 2017; Béjar and Rezac 2009; Kalin 2017; Levin 2018). When Agree-Copy fails to dereference a pointer introduced by Agree-Link, Agree Case can dereference the pointer by case-marking the goal.

Overall, the dissertation discusses six distinct operations and orders them as follows: Lexical Case  $\prec$  Dependent Case  $\prec$  Agree-Link  $\prec$  Fusion  $\prec$  Agree-Copy  $\prec$  Agree Case. I argue that the first three of these operations apply in the syntax while the latter three are post-syntactic operations.

## ACKNOWLEDGEMENTS

I have always enjoyed reading the acknowledgment sections of dissertations and thought they were the most fun parts to write. As I am trying to acknowledge all the people who have contributed to the fruition of this dissertation, I realize that it is a real challenge to express my gratitude. I have been very lucky to have worked with my committee members Mark C. Baker, Ken Safir, José Camacho, and Jonathan D. Bobaljik.

I have been extremely fortunate to have Mark as an advisor. He has an exceptional ability to express the most complex problems in the simplest and clearest possible way. I have learned a great deal from his lectures, a privilege that I am already missing. I have also learned how to formulate a problem, ask the right questions, and express them as clearly as possible thanks to Mark's teaching style and guidance. Mark has been an infinite source of inspiration and support. He taught me how to make observations, build theories step by step, test them rigorously, let them fall apart, and rebuild them stronger. I am deeply grateful for his advice, support, patience, and friendship. There is simply no way I can express my gratitude.

I have had the opportunity of being Ken's student and research assistant. Ken taught me how to read a paper, which I consider one of the most valuable skills a scientist can have. Thanks to his lectures, I have learned how to evaluate a theory by questioning every single component and making sure that it is actually needed. I have also learned from Ken that a Chomsky article must be read with a separate dictionary of acronyms. His comments on each draft of my dissertation was an immense contribution. I was also lucky to be Ken's research assistant for the Afranaph Project, which broadened my view on comparative syntax and typological research. My warmest thanks to Ken!

José was my syntax teacher in my first year. The most important thing I learned from

him was to think differently. As a first-year student, I would often find myself advocating a view without considering any alternatives. José would patiently and kindly show a different angle that would be a big revelation for me. During my dissertation work, he always gave insightful comments and encouraged me to think from different perspectives. I have benefited a lot from our conversations about the syntactic theory. I have also deeply enjoyed our conversations about the rivalry between our favorite football (soccer) teams, a rare find in the American academic circles. Thank you, José!

I would like to thank Jonathan for agreeing to join my committee. Jonathan has been a source of inspiration for me ever since I set my eyes on his work on Itelmen during my master's studies. The dissertation improved immensely thanks to his insightful comments on my various drafts. His keen observations has also opened up several paths for me to pursue after my dissertation. Thank you, Jonathan! It was a pleasure and a privilege to have you as a member of my dissertation committee.

In addition to my committee members, I would like to thank all the faculty members at Rutgers who had a lasting impact on my academic experience. Viviane Déprez was the interim graduate program director when I first arrived at Rutgers. She helped me navigate the early days of grad school. I've learned a great deal about the structure of the nominal phrase thanks to her seminar. She was also a committee member on my first qualifying paper and her insightful comments on my work contributed to the success of my work significantly. Viviane was always there whenever I needed support. Coincidentally, she is the graduate program director as I am graduating. She has literally signed me in and signed me off. Thank you, Viviane!

Jane Grimshaw has had an immense impact on my success in the linguistics program. Jane was a committee member on my second qualifying paper. She was also one of my favorite syntax teachers (like all of my other syntax teachers). Jane taught me how to ask questions and identify the key assumptions in each theory. She has taught me how to think like a linguist. I am indebted to her for all her support and kindness.

Veneeta Dayal is one of the kindest and dearest semantics teachers in the world and I am very lucky to have been her student. She chaired my second qualifying paper and has

taught me most of what I know in semantics. I have always considered myself a morpho-syntactician. Last week, my colleague at Facebook introduced me as a semanticist at a meeting. I think Veneeta would be proud and I don't know of a better way to thank her.

Another person who had a significant impact on my semantics knowledge has been Simon Charlow. I was not lucky enough to attend Simon's semantics lectures but he was a committee member on my second qualifying paper. I am grateful for his support and feedback for my work.

I was fortunate enough to have met Alan Prince and be among the last cohort of students taught by him before his retirement. Alan's passion for precision, attention to detail, and the depth of his knowledge in the scientific method has been a great source of inspiration and motivation for me.

I would like to thank Adam Jardine, Kristen Syrett, Paul de Lacy, Roger Schwarzschild, Maria Bittner, Akinbiyi Akinlabi, Simon Charlow, Troy Messick, Bruce Tesar, and Crystal Akers for being great teachers and building a great department for the graduate students at Rutgers.

I would like to thank my colleagues and friends at Rutgers, starting with my cohort: Yi-Hsun Chen, Natalie DelBusso, Luca Iacoponi, Satarupa Das; continuing with others whom I spent most of my time with: Yağmur Sağ, Shu-hao Shih, Hazel Mitchley, Kunio Kinjo, Morgan Moyer, Naga Selvanathan, Deepak Alok, Jess Law, Livia Souza, Elyesa Seidel, Nick Danis, Vera Gor, Diti Bhadra, Sarah Hansen, Vartan Haghverdi, Augustina Owusu, Lydia Newkirk, Tadjou-N'Dine Mamadou Yacoubou, Nick Winter, Haoze Li, Eileen Blum, Yu Cao, Megan Gotowski, Shiori Ikawa, Nathan Koser, Ang Li, Christopher Oakden, Akane Ohtaka; and ending with the ones I had the opportunity to share department with: Beibei Xu, Vandana Bajaj, Mingming Liu, Hope McManus, Matt Barros, Peter Staroverov, William Bennett, Věra Dvořák, Aaron Braver, Paula Houghton, Todor Koev, Jeremy Perkins, Teresa Torres Bustamente. I have had many stimulating conversations with each one of them. Thank you all! I also would like to thank our wonderful department administrators Marilyn Reyes and Ann Mazza.

I have presented my work at different venues and got feedback from many linguists. I would like to thank Faruk Akkuş, Laura Kalin, Arsalan Kahnemuyipour, Ted Levin, Daniel

Kaufman, Mitcho Erlewine, Omer Preminger, Einar Freyr Sigurðsson, Idan Landau, Franc Marušič, Andras Barány, Clifton Pye, Ömer Demirok, Deniz Özyıldız, İsa Kerem Bayırlı for stimulating conversations about my work and linguistics in general.

I also would like to express my deepest gratitude to my consultants Ayşehan Ortaç, Aijaz Ahmad, and Ismail Avcı Bucak'lışı; and my first linguistics teachers Balkız Öztürk Başaran, Sumru Özsoy, Eser Erguvanlı Taylan, Didar Akar, Aslı Göksel, Mine Nakipoğlu Demiralp, Meltem Kelepir, and Markus Pöchtrager. I owe them greatly.

Finally, I would like to thank my wife Tuba, the strongest woman in my life. She has supported me throughout the graduate school while she was also a grad student herself, writing her own dissertation, and doing the lion's share in taking care of our daughter. I could not have succeeded without her support. One last thank you to my daughter. She has patiently waited for mom and dad to finish their dissertations to spend more time with her.

Chapter 2 of this dissertation develops and extends Atlamaz and Baker (2016) and Atlamaz and Baker (2018). In both of these works, I was the primary author. Formulation of the research question, data collection, a substantial amount of the analysis, and the writing was done by me. Mark Baker chiefly contributed to the formulation of the analysis.



## **DEDICATION**

*To Tuba and Zeynep Eylül*

## TABLE OF CONTENTS

<b>Abstract</b> . . . . .	ii
<b>Acknowledgements</b> . . . . .	iv
<b>Dedication</b> . . . . .	viii
<b>List of Abbreviations</b> . . . . .	xii
<b>List of Symbols</b> . . . . .	xiii
<b>1. INTRODUCTION</b> . . . . .	1
1. Main Claim . . . . .	1
2. Methodology and Data . . . . .	4
3. Organization of the Dissertation . . . . .	5
3.1. Chapter 2: Case-sensitive agreement . . . . .	6
3.2. Chapter 3: Case-insensitive languages . . . . .	8
3.3. Chapter 4: Differential Object Marking . . . . .	8
<b>2. CASE-SENSITIVITY OF AGREEMENT</b> . . . . .	10
1. Introduction . . . . .	10
2. A Typology of Agreement-Case Interactions . . . . .	14
3. Hypotheses on Variation . . . . .	18
3.1. Agreement: Working definitions . . . . .	19
3.2. Hypotheses . . . . .	20
4. Kurmanji . . . . .	21

4.1.	Basic Case and Agreement Patterns . . . . .	21
	Present Tense . . . . .	22
	Past Tense . . . . .	23
4.2.	Verbal Morphology . . . . .	25
4.3.	Split Ergativity in Kurmanji . . . . .	30
5.	Accounting for Kurmanji Partial Agreement . . . . .	42
5.1.	Phi-visibility and Case Marking . . . . .	44
5.2.	Fusion in Kurmanji . . . . .	48
5.3.	A Theory of Morphology-sensitive Agreement . . . . .	51
6.	Extension to Other Languages . . . . .	60
6.1.	Accounting for Hindi – a <i>totally sensitive</i> language . . . . .	60
6.2.	Accounting for Faroese and Icelandic . . . . .	62
7.	Agreement with Objects in Kurmanji . . . . .	66
<b>3.</b>	<b>CASE-INSENTIVE LANGUAGES . . . . .</b>	<b>72</b>
1.	Laz . . . . .	75
2.	Minimal Search and Agree . . . . .	83
2.1.	Minimal Search as an operation employed by Agree . . . . .	83
2.2.	Section Summary . . . . .	93
3.	Parasitic Nature of Omnivorous Number Agreement . . . . .	93
4.	Person Prefixes in Laz . . . . .	95
5.	Turkish . . . . .	101
6.	Beyond the Typology . . . . .	117
<b>4.</b>	<b>DIFFERENTIAL OBJECT MARKING . . . . .</b>	<b>119</b>
1.	Introduction . . . . .	119
1.1.	A Brief Overview of DOM Literature . . . . .	122
1.2.	DOM in Three Sample Languages . . . . .	124
2.	DOM in Kashmiri . . . . .	134
3.	Theoretical Assumptions . . . . .	140

3.1.	Case . . . . .	140
3.2.	Licensing . . . . .	144
4.	Proposal . . . . .	149
4.1.	Licensing Marked Nominals . . . . .	149
4.2.	Licensing, PCC, and DOM . . . . .	152
5.	Analysis: Kashmiri DOM . . . . .	155
5.1.	Noun Phrase Objects and the Aspect Split . . . . .	155
5.2.	Entailment Relations and the Hierarchy Effects . . . . .	160
5.3.	Animacy Hierarchy Effects . . . . .	162
5.4.	Previous analyses of Kashmiri DOM . . . . .	172
6.	Back to Turkish and Hindi . . . . .	174
7.	Extending the Analysis to Senaya . . . . .	180
8.	Chapter Summary . . . . .	189
<b>5.</b>	<b>CONCLUSION . . . . .</b>	<b>190</b>
1.	Summary of Main Findings . . . . .	191
2.	Remaining Issues . . . . .	194
2.1.	Ordering the Proposed Operations . . . . .	194
2.2.	Interacting with other operations . . . . .	196
3.	Final Remarks . . . . .	197
	<b>Bibliography . . . . .</b>	<b>198</b>

## LIST OF ABBREVIATIONS

ABS	Absolutive	IMPF	Imperfective
ACC	Accusative	INF	Infinitive
AOR	Aorist	M	Masculine
APPL	Applicative	NMLZ	Nominalizer
CAUS	Causative	NEG	Negation
COND	Conditional	NOM	Nominative
COP	Copula	OBL	Oblique
DAT	Dative	OPT	Optative
DEF	Definite	P	Probe
DET	Determiner	PCC	Person Case Constraint
DIR	Direct	PERF	Perfective
DOM	Differential Object Marking	PIC	Phase Impenetrability Cond.
ERG	Ergative	PL	Plural
EVID	Evidential	PLC	Person Licensing Condition
EZ	Ezafe	POSS	Possessive
F(EM)	Feminine	PRES	Present Tense
FLC	Feature Licensing Condition	PROG	Progressive
FUT	Future	PART	Participle
G	Goal	SBJN	Subjunctive
GEN	Genitive	SG	Singular

## LIST OF SYMBOLS

⋈	precedes
⋈	is higher than, is more prominent than
⋈	c-commands, is structurally more prominent than
ϕ	phi
π	person
#	number
γ	gender
→	pointer
√	root
–	morpheme boundary
=	clitic boundary
∅	null, empty, absent

## 1

## INTRODUCTION

## 1 Main Claim

This dissertation examines the interaction of agreement and case. Its main focus is the cross-linguistic variation in case opacity and the role of agreement in case assignment. The main proposal that I argue for is that overt agreement and overt case are outputs of a set of distinct operations distributed across different modules of the grammar. More specifically, overt agreement is the output of two distinct operations, Agree-Link and Agree-Copy (Arregi and Nevins 2012) both of which have two parameters, Single and Multiple.

(1)	<b>OPERATION</b>	<b>PARAMETERS</b>
	Agree-Link	Single, Multiple
	Agree-Copy	Single, Multiple

Overt agreement is possible to the extent that both Agree-Link and Agree-Copy apply successfully. Agree-Link is a syntactic operation that establishes (asymmetric) one-to-one or one-to-many dependency relations between two or more syntactic objects (probes and goals). Agree-Copy is a post-syntactic operation that can read Agree-Link relations and transduce them into valuation on one of the syntactic objects (probe) by copying the feature values of the others (goals). Schematically, Agree-Copy takes (2) as input and returns (3).

(2) Input to Agree-Copy

$$P[ f1:\_, f2:\_, f3:\_ ] \xrightarrow{\text{Agree-Link}} G[ f1:\alpha, f2:\beta, f3:\gamma ]$$

(3) Output of Agree-Copy

$$P[ f1:\alpha, f2:\beta, f3:\gamma ]$$

Crucially, Agree-Copy is not the only operation that can interpret and transduce an Agree-Link relation. A second operation that can transduce an Agree-Link relation is Agree-Case. Agree-Case takes an Agree-Link relation and transduces it into case on the goal rather than valuation on the probe. Schematically, Agree-Case takes (2) as input and returns (4).

(4) Output of Agree-Case

$$G[ f1:\alpha, f2:\beta, f3:\gamma, Case:\sigma ]$$

To a certain degree, this approach resembles the Chomskyan (2000, 2001) view that agreement and case are two sides of the same coin. However, it differs from the traditional view in two ways. First, Agree-Copy and Agree-Case are distinct operations that can take similar inputs but return different outputs. In both processes, the Agree-Link relation is removed in the output. Hence, an Agree-Link relation can be realized either via Agree-Copy as overt agreement or via Agree-Case as overt case, but not both. Therefore, a given probe cannot show overt agreement with a goal and also assign it some case.<sup>1</sup> In this respect, the Agree-Copy vs. Agree-Case view is a modern incarnation of Nichols' (1986) Head-marking and Dependent-marking distinction. Agree-Copy results in Head-marking whereas Agree-Case yields Dependent-marking. Second, Agree-Case necessarily follows Agree-Link and it is responsible for only a fraction of overt case marking, Person Case Constraint "repairs" in general and a type of differential object marking in particular. There are other case-inducing operations like Lexical (inherent) Case (Legate 2008; Woolford 1997) and Dependent Case (Baker 2015; Bittner and Hale 1996; Marantz 1991) that necessarily precede Agree-Link.

---

<sup>1</sup>Case is not assigned by probes in this model, anyway.



Throughout the dissertation, I explore the set of agreement and case related operations listed in (5) and their relative orders as well as their locus across the syntactic and post-syntactic modules of the grammar.

(5)	OPERATION	SURFACE REALIZATION	LOCUS
	Agree-Link	agreement, case	Syntax
	Agree-Copy	agreement	Post-syntax
	Agree-Case	case	Post-syntax
	Lexical Case	case	Syntax
	Dependent Case	case	Syntax

Some of these operations are well-grounded in the literature (like Lexical Case and Dependent Case) while others are motivated based on i) derivational arguments through opacity and feeding/bleeding, ii) behavior of their outputs, and iii) the types of constraints that operate on them (locality, c-command). For example, Lexical Case and Dependent Case precede Agree-Link as evidenced by the opacity of some case marked nominals for agreement purposes (Chapter 2). Lexical Case distinguishes itself from Dependent Case and Agree-Case because Lexical Case can survive under passivization while the latter two cannot (Chapter 4).<sup>2</sup> Similarly, Agree-Case behaves differently from Lexical and Dependent Cases as it can appear in asymmetric differential object marking contexts while Lexical and Dependent cases cannot (Chapter 4).

One of the central operations that guides the exploration of operations across the syntactic and post-syntactic modules is Fusion. Fusion is a post-syntactic operation that takes two adjacent heads and fuses them into a single head without any internal syntactic structure (Halle and Marantz 1993). Given that Fusion is a post-syntactic operation, we can identify some of the post-syntactic operations by evaluating whether they feed off of the output of Fusion or not. I show that agreement in languages like Kurmanji, Faroese, and Icelandic is sensitive to Fusion, which motivates the post-syntactic Agree component, Agree-Copy. Overall, I propose the derivational order of operations given in (6).

<sup>2</sup>Passivization is a cover term for a number of different constructions. The assumption here is that passivization removes the external argument from the structure, at least for case and agreement purposes. There are contexts where a passive construction can have an implicit external argument that counts for case purposes. In such contexts, Dependent Case and Agree Case may remain intact.

## (6) Operations across modules

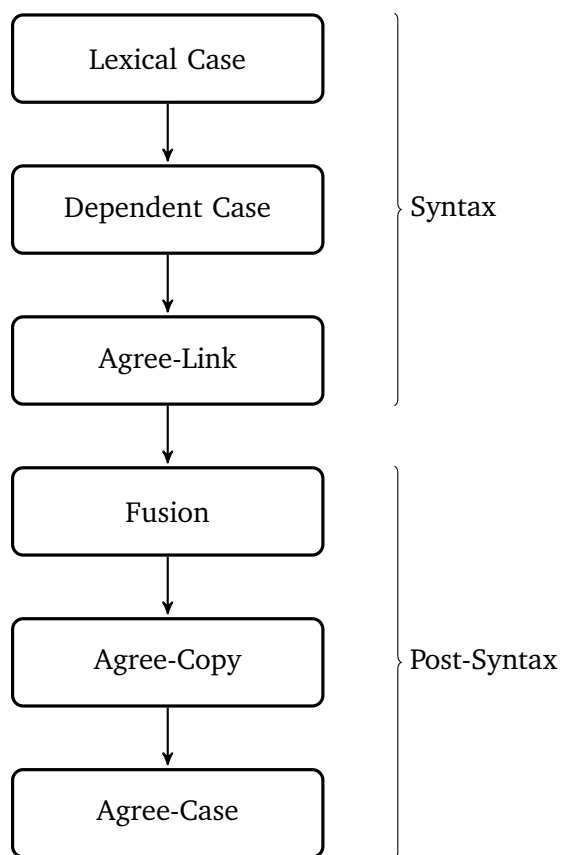

## 2 Methodology and Data

The methodology adopted in this dissertation aligns with formal generative typology as outlined by Baker (2010). Formal generative typology aims to establish what Baker and McCloskey (2007) call a “Middle Way” between a typological study and a generative study. Typological studies usually cover a large number of languages which prevents them from digging deep into the details of certain linguistic phenomena. On the other hand, generative studies usually focus on one or a few languages which might lead to incomplete cross-linguistic generalizations. The middle way allows a deeper analysis of wider cross-linguistic generalizations. Where possible, I try to provide a typological space defined by logical possibilities and illustrate each logical possibility with at least one language. For example, the question of whether overt case blocks agreement or not divides the typological space

into two logical possibilities. Among the languages where case blocks agreement, there is another division where in some languages (like Hindi) agreement is fully blocked while in others (like Kurmanji) it is only partially blocked.

The choice of languages in this dissertation is mostly a result of a convenience sampling within the tenets of the formal generative typology approach. The data on these languages come from various sources, including my own fieldwork. The table below aggregates the source information about each main language discussed in the dissertation.

(7)	LANGUAGE	SOURCE
	Faroese	Jónsson (2009) and Lockwood (1955)
	Icelandic	Holmberg and Hróarsdóttir (2004) and Thráinsson (1994)
	Hindi	Bhatt (2007a) and Bobaljik (2008), consultants
	Kashmiri	fieldwork, Bhatt (2013) and Wali and Koul (1997)
	Kurmanji	fieldwork
	Laz	Demirok (2013) and Öztürk and Pöchtrager (2011)
	Senaya	Kalin (2018) and Kalin and van Urk (2015)
	Turkish	Kornfilt (1977), consultants, own data

The Kurmanji data is from the Adıyaman dialect of Kurmanji spoken in the city of Adıyaman in southeastern Turkey. I collected Kurmanji data over the years through my interactions with the Kurmanji community in Turkey. Part of the data was collected during my fieldwork in Adıyaman in 2015, while some other data was collected from visiting consultants in New Jersey. I am a heritage speaker of Kurmanji. The Kashmiri data was collected in New Jersey in the Summer of 2017. My consultants were visiting scholars from Jammu and Kashmir and they identified themselves as native speakers of Kashmiri. Finally, unless otherwise noted, Turkish data are my own constructions confirmed with both linguist and non-linguist native speakers. I am a native speaker of Turkish.

### 3 Organization of the Dissertation

This section presents an overview of the dissertation by summarizing the main claims of each chapter. The dissertation is organized into two parts: the first part (Chapters 2 and 3) analyzes the cross-linguistic variation in agreement with overtly case-marked nominals, specifically focusing on Kurmanji, Hindi, Icelandic, Faroese, Turkish, and Laz. The second

part (Chapter 4) analyzes the interaction of agreement and case through a comparison of differential object marking in Kashmiri, Hindi, Turkish, and Senaya.

### 3.1 Chapter 2: Case-sensitive agreement

Chapter 2 focuses on the fact that in many languages overt case disturbs agreement with a potential goal. The main question entertained in this chapter is this: Why does overt case block agreement in some languages? I argue that this blocking is a Relativized Minimality effect. In languages where agreement is sensitive to case, agreement probes are underspecified. More specifically, I argue that in such languages agreement probes are specified for a [+N] feature rather than PERSON, NUMBER, or GENDER features. When an agreement probe looks for a goal, it finds the closest phrase with the [+N] feature. Following Lamontagne and Travis (1986), I assume case marked nominals to be case phrases (KP) headed by K. KPs have [+N] features by virtue of being extended nominal projections in Grimshaw's (1991) sense. Thus, the underspecified agreement probe looking for a [+N] feature establishes an Agree-Link relation with the KP but it cannot see past the KP due to Relativized Minimality.  $\varphi$ -features that are below the K head cannot be transferred to the agreement probe resulting in lack of overt agreement with overtly case marked nominals. This approach imposes an order among operations that assign case and establish agreement relations. This line of thought is an extension of Bobaljik (2008), but it differs from Bobaljik's proposal in certain ways. First, I argue that Agree-Link relations are established in the syntax but not post-syntactically. Second, I argue that some types of case assignment also occurs in the syntax, specifically before agreement relations can be established. The order of relevant operations is given in (8).

(8) Inherent Case  $\prec^3$  Dependent Case  $\prec$  Agree <sup>4</sup>

One of the key highlights of Chapter 2 is partially sensitive languages like Kurmanji, Faroese, and Icelandic where agreement with oblique subjects is partially disturbed. In Kurmanji,

<sup>3</sup>Indicates sequential ordering where the item on the left of ' $\prec$ ' precedes the item on the right of ' $\prec$ '.

<sup>4</sup>The relative order between Inherent Case and Dependent Case are not significant for the purposes of this dissertation. I just adopt the order proposed by Baker (2015) and Marantz (1991).

person and number agreement with oblique participant pronouns is totally banned whereas number agreement with oblique third person pronouns is possible under certain conditions. The availability of number agreement with oblique nominals in Kurmanji correlates with the fusion of plural and oblique features into a single morpheme. This motivates a two-step Agree model on the assumption that fusion is a post-syntactic morphological operation. Adopting the terminology from Arregi and Nevins (2012), I propose that agreement consists of two operations: Agree-Link and Agree-Copy. Agree-Link is a syntactic operation that establishes a relation between a probe and a goal by adding a pointer from a probe to a goal.<sup>5</sup> I argue that Agree-Link is syntactic because it obeys syntactic locality constraints (Relativized Minimality, Phases), uses syntactic dependencies like c-command, and establishes long distance dependencies between non-adjacent syntactic objects (like agreement between T and an internal argument).

The output of Agree-Link is fed into a number of post-syntactic operations including Agree-Copy. Agree-Copy takes an Agree-Link relation and replaces the pointer on a probe with the set of  $\varphi$ -features on the goal. Certain operations can apply before Agree-Copy and can change the structure of a goal in a way that makes Agree-Copy return a non-empty set of  $\varphi$ -features from a KP. One such operation is the post-syntactic operation Fusion, which combines two adjacent heads into one without any internal structure. In Kurmanji, plural fuses with oblique case in nominals without a PARTICIPANT feature. Fusion of plural with K allows Agree-Copy to transfer the plural feature to a probe. In contexts where nothing fuses with the oblique case, Agree-Copy returns an empty  $\varphi$ -set from the goal, resulting in a lack of agreement with an oblique goal. This analysis imposes a relative order between agreement related operations and other morpho-syntactic operations. A relevant portion of the order is given in (9).

(9) Agree-Link  $\prec$  Fusion  $\prec$  Agree-Copy

In Chapter 2, I extend the analysis of Kurmanji partial agreement facts to Faroese and Icelandic, both of which are languages where number fuses with overt case. I show that

---

<sup>5</sup>In languages with Multiple Agree, Agree-Link establishes one-to-many relations between a probe and all of its goals.

Faroese behaves exactly like Kurmanji. In Faroese, too, case fuses with number in third person pronouns. Number agreement with third person pronouns is possible as a result of fusion whereas no agreement is possible with participant pronouns where fusion is not observed. In contrast to Faroese and Kurmanji, Icelandic has some ostensible differences in agreement with overtly case-marked nominals. In Icelandic, number fuses with case but in most configurations agreement with a dative subject is not possible despite fusion. I claim that, in Icelandic, the lack of agreement despite fusion is due to the specificity of the verbal agreement morphemes, which are too specific to be inserted at a probe that has only a plural feature. This is a result of the Subset Principle of Halle and Marantz (1993).

### **3.2 Chapter 3: Case-insensitive languages**

Chapter 3 examines the interaction of overt case and agreement in Laz and Turkish – two languages where overt case does not block agreement at all despite the absence of any fusion between case and  $\varphi$ -features. I claim that the case-insensitivity of agreement in these languages is also a Relativized Minimality effect. In Laz and Turkish, agreement probes are specified for PERSON and NUMBER features and they are introduced as separate heads. Adopting the Relativized Probing view of (Nevins 2011; Preminger 2014), I argue that in these languages, number and person probes can skip the irrelevant interveners including KP and find the relevant  $\varphi$ -features on case-marked goals. Unlike in Kurmanji where the agreement probe is specified for the [+N] feature, in Laz and Turkish KPs do not intervene because they do not have the features that the probe is specified for.

Besides analyzing Laz and Turkish, Chapter 3 introduces a work-in-progress version of Minimal Search based on the graph-theoretic search algorithms used in the computer sciences and graph theory. While speculative in nature, it aims to provide a derivational account of locality based on a search algorithm instead of the representational c-command geometry, as groundwork for future research.

### **3.3 Chapter 4: Differential Object Marking**

Chapter 4 investigates the interaction between overt case and agreement through differential object marking (DOM). I start by comparing DOM in Turkish, Hindi, and Kashmiri along

three dimensions: passivization, asymmetric DOM, and variation in DOM across clauses with different tense/aspect. In all these languages, the DOM case is lost under passivization, which indicates that DOM is a structurally assigned case. Hindi and Turkish disallow asymmetric DOM, in which one conjunct of a conjunction phrase receives DOM while the other one remains unmarked. In contrast, Kashmiri allows asymmetric DOM. Further, DOM in Turkish and Hindi does not vary across tenses or aspects whereas in Kashmiri, DOM takes place in imperfective clauses but not in perfective clauses where the clausal alignment is ergative. The differences between these languages motivate a non-unified analysis of differential object marking. I argue that in Hindi and Turkish, DOM is the result of Dependent Case assignment while in Kashmiri, DOM is a result of nominal licensing. I show that in Kashmiri, DOM correlates with the presence of overt agreement between T and an object. Extending the two-step Agree mechanism developed in the first part of the dissertation, I claim that DOM in Kashmiri is a type of PCC repair assigned by Agree-Case. In contexts where an agreement probe establishes Agree-Link relations with two goals but Agree-Copy can resolve only one of these Agree-Link relations, Agree-Case resolves the remaining link by marking the goal rather than the probe. This imposes a sequential order among the other Agree operations and Agree-Case as in (10).

(10) Agree-Link  $\prec$  Agree-Copy  $\prec$  Agree-Case

Agree-Case is a post-syntactic operation that applies after Agree-Copy and resolves the Agree-Link relations by marking the goal but not the probe. This can be considered as a contemporary (Minimalist) implementation of Dependent Marking proposed by Nichols (1986). This proposal also ties some of case assignment to agreement and supports the GB and early Minimalist views about case and agreement being two sides of the same coin (Chomsky 2000, 2001). I finish Chapter 4 by extending the analysis developed for Kashmiri to Senaya.

Finally, Chapter 5 provides a quick overview of the dissertation and discusses some remaining issues to lay some groundwork for future research.

## 2

## CASE-SENSITIVITY OF AGREEMENT

### 1 Introduction

Overt case famously disturbs agreement in many languages. One well-known example is the (apparent) lack of agreement with dative subjects in Icelandic. In Icelandic, external arguments of some experiencer predicates get dative case.

- (1) Mér virðast hestarnir vera seinir.  
 1SG.DAT seem.PL horse.PL.DEF.NOM be slow  
 'It seems to me that the horses are slow.' (Holmberg and Hróarsdóttir 2004, p. 652)

What is crucial in (1) is that the verb does not agree with the dative subject but instead, agrees with the nominative object. This type of data has motivated theories like *Case Opacity* and the *Activity Condition*.

- (2) *Case Opacity* (Schütze 1997)

An inherently case marked NP cannot value a  $\varphi$ -feature.

- (3) *Activity Condition* (Chomsky 2000, 2001)

A goal G is eligible for Agree if and only if G has at least one uninterpretable feature.

Case Opacity refers to the observation that inherently case marked nominals cannot



value a  $\varphi$ -probe. Chomsky's Activity Condition builds on Case Opacity. In Chomsky's Agree-centric case view, structural case is assigned to NPs with uninterpretable case features via agreement with a F(unctional) head. In order for an F head to assign case to an NP, F must agree with the NP. This agreement is only possible when the NP has some uninterpretable case feature. NPs without uninterpretable case features are invisible for agreement purposes. Once an NP receives case, its uninterpretable case feature is valued and the uninterpretability is deleted. This prevents any agreement with an inherently case marked nominal as inherent case is assigned by the lexical head that introduces the NP. The lack of agreement with the dative subject in (1) is a matter of Case Opacity and it is due to the Activity Condition.

The predictions of Case Opacity and the Activity Condition are quite clear. If an NP has already received case by the time Agree applies, the result is no agreement. One thing that is not quite clear is the status of the underlying facts. There are two ways to interpret the cases of *no agreement*.

- (4) a. Agree cannot see a case marked NP. (No abstract agreement, No surface agreement)
- b. Agree can see a case marked NP but cannot copy  $\varphi$ -values. (Abstract agreement, No surface agreement)

Given defective intervention facts from languages like Icelandic, (4-b) sounds more plausible because a strict interpretation of (4-a) predicts defective intervention not to exist. If Agree cannot see a case marked NP, then the invisible NP should not intervene agreement with a lower nominal. Yet, this is exactly what happens in clauses like (5). The dative subject cannot be agreed with yet, it still intervenes agreement between the probe and the internal argument.

- (5) Ðað virðist / \*virðast einhverjum manni hestarnir vera seinir.  
 EXPL seem.SG / seem.PL some man.DAT horse.PL.DEF.NOM be slow  
 'It seems to some man that the horses are slow.' (Holmberg and Hróarsdóttir 2004)

Although they make different predictions with respect to abstract agreement, both (4-a)

and (4-b) predict the following generalization.

(6) Case marked NP → No surface agreement

Later work on the interaction of case and agreement revealed that the facts are more complicated than described by Case Opacity. Bobaljik (2008) and Baker (2008) show that languages differ in their agreement patterns with overtly case marked nominals. For example, in Hindi, an overtly case marked nominal is not agreed with at all. In (7-a), the subject is morphologically unmarked for case and the verb agrees with it in gender.

- (7) a. Siita baazaar gayii.  
Sita.FEM market go.PAST.FEM.SG  
'Sita went to the market.'
- b. Raam-ne roṭii khyaayii thii.  
Raam.MASC-ERG bread.FEM eat.PERF.FEM be.PAST.FEM  
'Ram had eaten bread.' (Mahajan 1990a, p. 73)
- c. Siita-ne larkii-ko dekhaa.  
Sita.FEM-ERG girl.FEM-ACC see.PERF.MASC  
'Sita saw the girl.' (Bobaljik 2008)

In (7-b), the subject is overtly case marked with ergative case and the verb shows agreement with the morphologically unmarked object NP rather than with the subject. In (7-c), both the subject and the object are overtly case marked and the verb does not agree with either. Instead, default masculine agreement shows up on the verb despite both of the arguments being feminine.

In some other languages like Nepali, the verb can agree with an overtly case marked NP as in (8-b).<sup>1</sup>

- (8) a. ma yas pasal-mā patrikā kin-ch-u.  
**1.SG.NOM** DEM.OBL store-LOC newspaper.NOM buy-NPST-**1SG**  
'I bought the newspaper in this store.'
- b. maile yas pasal-mā patrikā kin-ē.  
**1.SG.ERG** DEM.OBL store-LOC newspaper.NOM buy-PST-**1SG**  
'I bought the newspaper in this store.' (Bobaljik 2008, p. 310)

<sup>1</sup>In fact, the generalization is slightly different for Nepali, according to Bobaljik (2008). In Nepali, the verb shows agreement with nominative and ergative NPs but not oblique NPs.

Bobaljik (2008) observes an implicational hierarchy on the interaction of agreement and case. Languages show variation in terms of agreement with a case marked NP and this variation is captured by the implicational hierarchy in (9).

(9) Unmarked Case  $\leftarrow$  Dependent Case  $\leftarrow$  Lexical/Oblique Case (Bobaljik 2008)

Based on (9), in languages where NPs with dependent case are agreed with, then NPs with unmarked case must also be agreed with. On the other hand, this does not necessarily mean that NPs with lexical/oblique case are also agreed with. Bobaljik supports the implicational hierarchy in (9) with the typology in (10).

(10)	<b>ATTESTED</b> a. no agreement (Dyirbal, Lezgian) b. ABS only (Hindi, Tsez) c. ABS ERG (Eskimo-Inuit, Mayan) d. ABS ERG DAT (Basque, Abkhaz)	<b>UNATTESTED</b> e. * ERG only f. * ERG DAT, not ABS g. * DAT only h. * ABS DAT, not ERG
------	---	---

The cross-linguistic variation in the accessibility of a noun phrase for agreement purposes is then determined by language specific choices on the implicational hierarchy in (9). As it stands, this is an externally imposed parameter choice on languages. Preminger (2014) builds on this idea and attributes the variation to the differences in  $\varphi$ -features across languages. For example, in Hindi, the  $\varphi$ -probe is relativized for unmarked case while in Nepali it is relativized for dependent case. This type of explanation fits within the tenets of Borer-Chomsky conjecture (Borer 1984; Chomsky 1995), which attributes parametric variation to the properties of lexical items. One formulation of the Borer-Chomsky conjecture is given in Baker 2008.

(11) *The Borer-Chomsky Conjecture* (Baker 2008, p. 156)

All parameters of variation are attributable to differences in features of particular items (e.g. the functional heads) in the lexicon.

The idea that languages make parametric choices in agreeing with a case marked nominal or not has also been proposed by Baker (2008). Baker proposes the Case-Dependency of

Agreement Parameter.

(12) *The Case-Dependency of Agreement Parameter* (Baker 2008, p. 155)

F agrees with DP/NP only if F values the case feature of DP/NP or vice versa.

The parameter in (12) makes a distinction between languages where agreement is not sensitive to case at all versus languages in which agreement and case are correlated. When the parameter is set to *off*, agreement is not sensitive to case at all. On the other hand, when the parameter is set to *on*, only NPs that are not yet case marked can be agreed with. This predicts that in languages where the case-dependency parameter is *on*, lexically case marked nominals cannot be agreed with.

One common property among the theories proposed by Baker (2008), Bobaljik (2008), Chomsky (2000, 2001), and Preminger (2014) is that they are all categorical. For Chomsky (2000, 2001), a case marked nominal cannot be agreed with. For the others, an NP with a specific case can either be agreed with or not agreed with depending on the language. For example, an ergative NP cannot be agreed with in Hindi while it can be agreed with in Nepali. There are some facts from a range of languages that cannot be captured by categorical approaches. In the next section, I provide a new typology and highlight the need for a new theory to explain the cross-linguistic variation presented by this typology.

## 2 A Typology of Agreement-Case Interactions

As discussed in the previous section, languages differ in whether overt case blocks agreement or not. I call this blocking effect *case sensitivity* of agreement. On a broader level, languages can be *case sensitive* or *case insensitive* with respect to agreement.

(13) *Case Sensitivity of Agreement*

- a. **Case Sensitive:** In languages where agreement between a probe and a potential goal is disturbed in any way because of the case marking on the potential goal, agreement is *case sensitive*. I call such languages, *case sensitive* languages.

- b. **Case Insensitive:** In languages where agreement between a probe and a potential goal is not disturbed by the case marking on the potential goal, agreement is *case insensitive*. I call these languages *case insensitive* languages.

In some languages, case sensitivity is total, yielding no agreement with an overtly case marked nominal at all. The main example in the previous section was from Hindi. In Hindi, overtly case marked nominals cannot be agreed with at all.

- (14) a. Siita baazaar gayii.  
Sita.FEM market go.PAST.FEM.SG  
'Sita went to the market.'
- b. Siita-ne larkii-ko dekhaa.  
Sita.FEM-ERG girl.FEM-ACC see.PERF.MASC  
'Sita saw the girl.'
- (Bobaljik 2008)

The facts are similar in Tsez, Kashmiri, Tamil among others. For example, in Tsez, absolutive NPs, which are morphologically unmarked, can be agreed with in class, while ergative NPs cannot.

- (15) a. Ziya b-ik'i-s  
cow.III.ABS III-go-PST.EVID  
'The cow left.'
- b. Eniy-ā ziya b-išer-si  
mother-ERG cow.III.ABS III-feed-PST.EVID  
'The mother fed the cow.'
- (Polinsky and Potsdam 2001, p. 586)

In languages like Hindi and Tsez, the sensitivity of agreement to case is total. Agreement is totally blocked by the presence of the overt case on a nominal. I call such languages *totally sensitive* and the phenomenon *total sensitivity*.

(16) *Totally Sensitive Languages*

A language is *totally sensitive* if overt case on a potential goal blocks agreement with that goal totally.

A second type of language where agreement is sensitive to overt case is what I call *partially sensitive* languages. Although these languages have been reported in the literature, the partial agreement facts in such languages have not been investigated systematically until Atlamaz and Baker (2018). What makes these languages significant is that overt case blocks agreement with some nominals but not others. Kurmanji is such a *partially sensitive* language. In Kurmanji, first and second person pronouns cannot be agreed with when they are overtly case marked.

- (17) a. M-e hew di / \*di-n.  
**1PL-OBL** 3SG.DIR saw / saw-PL  
 ‘We saw her/him/it.’
- b. W-e hew di / \*di-n.  
**2PL-OBL** 3SG.DIR saw / saw-PL  
 ‘You saw her/him/it.’ (Atlamaz and Baker 2018)

On the other hand, third person oblique subjects can be agreed with in number.

- (18) a. Wan-a hew di-n.  
**3-PL.OBL** 3SG.DIR **saw-PL**  
 ‘They saw her/him/it.’
- b. Keçik-a hew di-n.  
**girl-PL.OBL** 3SG.DIR **saw-PL**  
 ‘The girls saw her/him/it.’ (Atlamaz and Baker 2018)

Kurmanji is not alone in displaying partial sensitivity. Some other languages that have similar partial agreement facts are Faroese, Icelandic<sup>2</sup>, and West Beluchi. For example, Jónsson (2009) shows that in Faroese, third person plural dative subjects can be agreed with in number.

- (19) a. **Liðunum** mangla venjara.  
 team.PL.THE.DAT lack.3PL trainer.acc  
 ‘The teams need (lack) [a] trainer.’
- b. **Børnunum** tørva eina góða fyrimynd.  
 child.PL.THE.DAT need.3PL a.ACC good.ACC role.model.ACC  
 ‘The children need a good role model.’

<sup>2</sup>Icelandic facts are quite complex and are discussed in section 6.2.

- c. Teimum dáma at vera saman í bólki.  
 3PL.DAT like.3PL to be together in band  
 ‘They like to be together in the band.’ Faroese (Jónsson 2009, p. 156)

On the other hand, agreement with a dative first person is not possible. Instead, the verb shows default third person agreement as in (21).

- (20) \*Mær dámi Hasa bókina.  
 1SG.DAT like.1SG this.ACC book.DEF.ACC  
 ‘I like this book.’ Faroese (Jónsson 2009, p. 159)

- (21) Mær dámar væl sterkan mat.  
 1SG.DAT like.3SG well spicy.ACC food.ACC  
 ‘I like spicy food well.’ Faroese (Jónsson 2009, p. 154)

The *partial sensitivity* observed in Kurmanji and Faroese clauses in (17)-(21) cannot be accounted for by the categorical approaches discussed in the previous section. The categorical approaches predict either no agreement with an oblique nominal or complete agreement with it. The fact that some oblique nominals cannot be agreed with at all while others can be agreed with in number calls for an explanation. Such facts also show that languages in which agreement is case sensitive are not uniform. There are at least two types of such languages, *totally sensitive* languages and *partially sensitive* languages. The typology of case sensitive agreement is given in (22).

- (22)
- |                                 |                                   |
|---------------------------------|-----------------------------------|
| <b>CASE-SENSITIVE LANGUAGES</b> |                                   |
| <b>TOTALLY SENSITIVE</b>        | <b>PARTIALLY SENSITIVE</b>        |
| Hindi, Tsez, Tamil, ...         | Kurmanji, Faroese, Icelandic, ... |

In addition to the languages in which agreement is sensitive to case, there is a third type where agreement is not sensitive to case at all. As discussed in the previous section, Nepali is one such language. Similarly, Laz, Turkish, Burushaski, and Basque are such languages where a given NP can be agreed with no matter what its case marking is. I call these languages *case insensitive* languages where with a potential goal is not disturbed by case

marking on the goal at all. Considering these languages along with the case sensitive languages, we get the typology in (23).

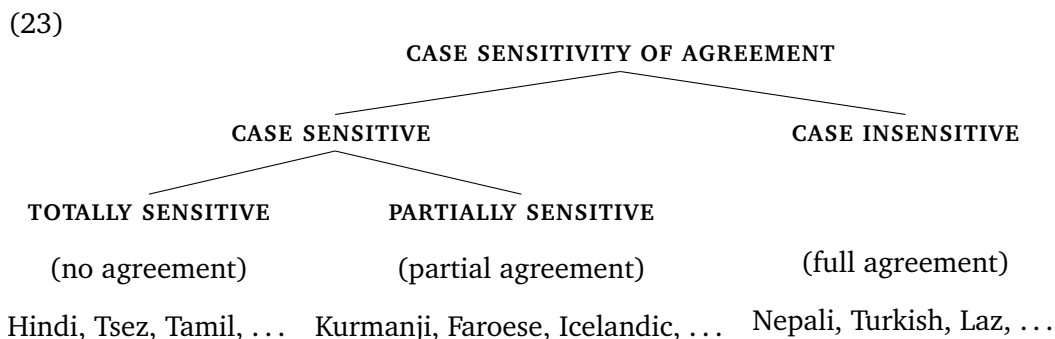

The facts discussed so far raise a number of questions, some of which are novel while others are long-standing. Why does overt case disturb agreement in case sensitive languages and why does it not disturb agreement in case-insensitive languages? How does partial agreement work? These questions are summarized in (24).

- (24) a. Where does the cross-linguistic variation come from?  
 b. How does partial agreement work?

Questions (24-a) and (24-b) form the basis of this chapter and the next one. In this chapter, I provide an account of partial agreement that also captures the typology of case sensitive languages. In the next chapter, I analyze case insensitive languages. In the following sections, I entertain two hypotheses about the cross-linguistic variation described by the typology in (23). Then, I build a theory of partial agreement based on Kurmanji case and agreement interactions. As a case sensitive language, Kurmanji also provides a testing ground for the hypotheses developed in the following section.

### 3 Hypotheses on Variation

Agreement is a phenomenon where a lot of variation is observed across languages. There are languages where agreement does not happen at all (Dyirbal, Lezgian, Mandarin, etc.). In some languages, only T agrees, while in others both T and *v* agree, and in yet some others



T,  $v$ , and C all agree.<sup>3</sup> Then, there is the type of variation discussed in the previous chapter where agreement shows variation in its interaction with overtly case-marked nominals. The amount of variation is massive and one of the most pressing questions is the source of variation. In the following, I provide a set of assumptions, working definitions and two hypotheses regarding the variation.

### 3.1 Agreement: Working definitions

A barebones definition of agreement involves three components, a dependent (probe), a dependee (goal), and an operation (Agree) that establishes a relation between the two syntactic objects (dependee and dependent) and copies the  $\varphi$ -values from the dependee onto the dependent.

(25) *Components of Agreement*

- a. Agree (Operation)
- b. Probe (Syntactic Object)
- c. Goal (Syntactic Object)

Keeping other factors (like locality) constant, all the variation in agreement should come from the independent properties of these three components of agreement. I assume that Agree is a hard-wired operation available in all languages in principle. For now, I take the definition of Agree in (26).

(26) *Agree* (to be revised)

Agree is an operation that takes a probe and a goal as input and returns a probe with  $\varphi$ -feature values copied from the goal.

---

<sup>3</sup>See Baker (2008, Ch. 5) for a discussion of variation.

Other definitions are as follows:

(27) *Syntactic Objects*

a. Probe:

A Probe is a functional head with unvalued  $\varphi$ -features.

b. Goal:

A goal is a maximal projection with valued  $\varphi$ -features.

### 3.2 Hypotheses

Assuming that Agree is a universal operation, all the variation should follow from the independent properties of the probes or the goals.<sup>4</sup> The two hypotheses that I entertain in this chapter are:

(28) **Hypothesis I** – Different Goals

Cross-linguistic variation in agreement is due to the differences in the structures of goals.

(29) **Hypothesis II** – Different Probes

Cross-linguistic variation in agreement is due to the differences in the structures of probes.

Hypothesis II is an example of the Borer-Chomsky Conjecture discussed in the previous section. Hypothesis I adds to the Borer-Chomsky Conjecture by considering the properties of the goals and their structure. These hypotheses build all the variation on the lexical properties of functional heads and the morpho-syntactic structure.

In the following sections, I show that Hypothesis I is relevant to the variation among

---

<sup>4</sup>This assumption raises some questions about languages like Dyrbal, Lezgian, etc. where agreement is not observed. If Agree is a universal operation, one might expect to see agreement in every language. It is worth clarifying the distinction between Agree and agreement. Agree is the universally available operation that applies when conditions are met while agreement is roughly the phenomenon observable in the form of  $\varphi$ -feature correlation between a verb-like element and a noun-like element. The lack of agreement is not evidence for the lack of Agree. I argue that in these languages, there is no probe. Being a probe is a lexical property that varies across languages. Thus, the lack of agreement in some languages can still be accounted for within the tenets of Hypothesis II.

case sensitive languages. I also argue that the difference between case sensitive and case insensitive languages is due the differences in their probes, confirming Hypothesis II.

(30) *Main Claim*

All the cross-linguistic variation in the interaction between agreement and overt case follows from the lexical properties of probes and the structures of goals.

Partially sensitive languages provide a good testing ground for these hypotheses as they show a certain amount of variation within a single language. A theory that explains the variation in a single language has the potential to explain the cross-linguistic variation as well. In the next section, I provide some background on Kurmanji, which is a good testing ground for hypotheses in (28) and (29) because it has instances of all the types in the typology given in (23), NO, PARTIAL, and FULL agreement.

## 4 Kurmanji

Kurmanji (ISO 639-3: [kmr]) is an Iranian language mostly spoken in southeastern Turkey. It is also called Northern Kurdish constituting the Kurdish macrolanguage with the central and southern varieties. The Kurmanji data in this dissertation comes from the Adiyaman dialect gathered through fieldwork. In many relevant respects, the Adiyaman dialect is similar to the “standard dialect” described by Thackston (2006). Throughout the dissertation, I refer to it as Kurmanji. In cases when I report data from other Kurmanji varieties, I explicitly state the variety.

On the empirical side, Kurmanji is an understudied language that needs much documentation. On the theoretical side, it is highly relevant that it has forms of tense-based split ergativity which correlates with agreement and has partial agreement. In the following subsections, I discuss some key properties of the Kurmanji case and agreement system.

### 4.1 Basic Case and Agreement Patterns

Kurmanji is a two-case language with a tense-based split ergativity. Nominals can be found in bare form, traditionally called direct case, or in a morphologically marked form called

the oblique case. The forms of pronouns are given in (31).

(31)	PERSON	DIRECT		OBLIQUE	
		SG	PL	SG	PL
	1	ez	em	mı(n)	me
	2	tı	un	te	we
	3 <sub>em</sub>	hew(a)	hewna	wê	wana
	3 <sub>masc</sub>	hew(a)	hewna	wi	wana

Direct nouns are morphologically unmarked whereas oblique nouns usually get an identifiable oblique suffix except for some irregular nouns whose roots change depending on the case. Plural forms of direct nouns are the same as their singular counterparts. Oblique nominals reflect number distinctions through a portmanteau morpheme that expones both number and case.

(32)	NOUN	DIRECT		OBLIQUE	
		SG	PL	SG	PL
	girl	keçık	keçık	keçık-ê	keçık-a
	book	kitaw	kitaw	kitaw-ê	kitaw-a
	goat	bızın	bızın	bızın-ê	bızın-a
	<b>IRREGULAR FORMS</b>				
	boy	lawık	lawık	lêwık	lawık-a

Present tense clauses in Kurmanji have an accusative alignment whereas past tense clauses display an ergative alignment.

### Present Tense

In present tense, subjects are uniformly treated and they are all morphologically unmarked while the objects of transitive clauses are in oblique form.

#### (33) Intransitive Clauses

- a. Ez        dı-rv-ım-e.  
 1SG.DIR IMPF-run-1SG-COP  
 'I am running.'

- b. Tı dı-rv-ê.  
2SG.DIR IMPF-run-2SG.COP  
'You are running.'
- c. Hew dı-rv-ê.  
3SG.DIR IMPF-run-3SG.COP  
'She/he/it is running.'
- d. Em/un/hewna dı-rv-in-e.  
1PL.DIR/2PL.DIR/3PL.DIR IMPF-run-PL-COP  
'We/you/they are running.'

## (34) Transitive Clauses

- a. Ez keçık-ê dı-wun-im-e.  
1SG.DIR girl-OBL IMPF-see-1SG-COP  
'I see the girl.'
- b. Tı keçık-ê dı-wun-ê.  
2SG.DIR girl-OBL IMPF-see-2SG.COP  
'You see the girl.'
- c. Hew keçık-ê dı-wun-ê.  
3SG.DIR girl-OBL IMPF-see-2SG.COP  
'She/he/it sees the girl.'
- d. Em/un/hewna keçık-ê dı-wun-in-e.  
1PL.DIR/2PL.DIR/3PL.DIR girl-OBL IMPF-see-PL-COP  
'We/you/they see the girl.'

In present tense clauses, the verb agrees with the subject in person and number.

**Past Tense**

In past tense clauses, intransitive subjects and transitive objects get direct case while transitive subjects get oblique case. In most situations, agreement tracks the morphologically unmarked nominal.

## (35) Intransitive Clauses

- a. Ez rv-i-m.  
1SG.DIR run-PAST-1SG  
'I ran.'
- b. Tı rv-i-yi.  
2SG.DIR run-PAST-2SG  
'You ran.'

- c. Hew rv-i.  
3SG.DIR run-PAST  
'She/he/it is running.'
- d. **Em** rv-i-**n(i)**.  
1PL.DIR run-PAST-(1)PL  
'We ran.'
- e. **Un/hewna** rv-i-**n**.  
2PL.DIR/3PL.DIR run-PAST-PL  
'You/they ran.'

## (36) Transitive clauses

- a. Mı keçik di.  
1SG.OBL girl.DIR see.PAST  
'I saw the girl.'
- b. Mı **tı** di-**yi**.  
1SG.OBL 2SG.DIR see.PAST-2SG  
'I saw you.'
- c. Te **ez** di-**m**.  
2SG.OBL 1SG.DIR see.PAST-1SG  
'You saw me.'
- d. Wê/wi **ez** di-**m**.  
3SG.FEM.OBL/3SG.MASC.OBL 1SG.DIR see.PAST-1SG  
'She/he/it saw me.'
- e. Me **tı** di-**yi**.  
1SG.OBL 2SG.DIR see.PAST-2SG  
'We saw you.'
- f. We/wana **ez** di-**m**.  
1PL.OBL/3PL.OBL 1SG.DIR see.PAST-1SG  
'You/they saw me.'

In a small part of the paradigm, the verb shows optional agreement with third oblique subjects. When the object is third singular and the subject is third plural, the verb optionally shows plural agreement with the oblique subject.

- (37) a. Keçik-a hew di-n.  
girl-PL.OBL 3SG.DIR see.PAST-PL  
'The girls saw her/him/it.'

- b. Wana hew di-n.  
 3PL.OBL 3SG.DIR see.PAST-PL  
 ‘They saw her/him/it.’

This type of agreement is not possible with participant pronouns, neither in person nor in number.

- (38) a. \*M<sub>1</sub> hew di-m.  
 1SG.OBL 3SG.DIR see.PAST-1SG  
 ‘I saw her/him/it.’
- b. \*Te hew di-yi  
 2SG.OBL 3SG.DIR see.PAST-2SG  
 ‘You saw her/him/it.’
- c. \*Me / we hew di-n.  
 1PL.OBL / 2PL.OBL 3SG.DIR see.PAST-PL  
 ‘We/you saw her/him/it.’

Plural agreement with third oblique subjects is not possible when the object is first or second person.

- (39) a. Keçik-a ez di-m / \*di-n.  
 girl-PL.OBL 1SG.DIR see.PAST-1SG / see.PAST-PL  
 ‘The girls saw me.’
- b. Wana tı di-yi / \*di-n.  
 3PL.OBL 2SG.DIR see.PAST-2SG / see.PAST-PL  
 ‘They saw you.’

In Kurmanji, oblique participant pronouns cannot be agreed with while other oblique nominals trigger number agreement in certain configurations. I call this *partial agreement* in the sense that some of the oblique nominals (common nouns and 3rd pronouns) can be agreed with while others (participant pronouns) cannot. This partial agreement is not predicted by the theories of case-sensitive agreement discussed in the introduction.

## 4.2 Verbal Morphology

Like many Iranian languages, Kurmanji has a “stem” based verbal morphology. The innermost part of a verbal complex is the “stem” which consists of the verb root and some sort

of a tense information. In many cases, root+tense is suppletive making it impossible to decompose morphologically.

(40)	VERB	present	past	(Kalin and Atlamaz 2015)
	go	<i>her</i>	<i>çün</i>	
	eat	<i>x</i>	<i>xar</i>	
	see	<i>wun</i>	<i>di</i>	

In many other cases, the past stem is built by adding the *-i* or *-t* suffix on the verb root.

(41)	VERB	present	past	(Kalin and Atlamaz 2015)
	boil	<i>kel</i>	<i>keli</i>	
	rain	<i>bar</i>	<i>bari</i>	
	buy	<i>kurr</i>	<i>kurri</i>	
	hear	<i>biz</i>	<i>bist</i>	
	hold	<i>gr</i>	<i>girt</i>	
	want	<i>xaz</i>	<i>xast</i>	

Based on the examples in (41), Kalin and Atlamaz (2015) argue that the “stems” are in fact compositional and they consist of a root plus a tense morpheme.

(42)	present	past
	$\sqrt{\text{root}}+\emptyset$	$\sqrt{\text{root}}+i/t$

Split ergativity in Kurmanji correlates with the changes in the root+tense. Unlike most Indo-Aryan languages, split ergativity in Kurmanji has been argued not to be correlated with aspect. Gündoğdu (2011) argues that split ergativity is not correlated with aspect in Kurmanji. (43) illustrates a contrast between a perfective and an imperfective clause and in both, the alignment is ergative.

- |      |    |                           |           |                      |  |
|------|----|---------------------------|-----------|----------------------|--|
| (43) | a. | M <sub>1</sub>            | nan       | xar.                 |  |
|      |    | 1 SG.OBL                  | bread.DIR | eat.PAST             |  |
|      |    | 'I ate the bread.'        |           |                      |  |
|      | b. | M <sub>1</sub>            | nan       | d <sub>1</sub> -xar. |  |
|      |    | 1 SG.OBL                  | bread.DIR | IMPF-eat.PAST        |  |
|      |    | 'I was eating the bread.' |           |                      |  |



In addition to the root+tense, Kurmanji verbal complex can host a number of other affixes. One of these affixes is the imperfective (IMPF) prefix *dɪ-* seen in (43-b). The imperfective prefix is in complementary distribution with the subjunctive (SBJN) mood prefix *bɪ-*.

- (44) a. Ez nê n nê dɪ-x-Ø-ɪm.  
1 SG.DIR bread.OBL IMPF-eat-PRES-1 SG  
'I eat bread.'
- b. Ez nê n nê bɪ-x-Ø-ɪm.  
1 SG.DIR bread.OBL SBJN-eat-PRES-1 SG  
'that I eat bread.'
- c. Ez nê n nê \*bɪ-dɪ-x-Ø-ɪm. / \*dɪ-bɪ-x-Ø-ɪm.  
1 SG.DIR bread.OBL SBJN-IMPV-eat-PRES-1 SG / IMPV-SBJN-eat-PRES-1 SG  
'that I eat bread.'

On some rare occasions, the imperfective prefix fuses with the verb root.

- (45) Mehemed tê-Ø  
Mehemed.DIR IMPV.come-PRES  
'Mehemed comes.'

In past tense clauses, the verbal complex can host a negation (NEG) morpheme that precedes the imperfective prefix.

- (46) a. Mɪ ne-xar.  
1 SG.OBL NEG-eat.PAST  
'I didn't eat.'
- b. Mɪ ne-dɪ-xar.  
1 SG.OBL NEG-IMPV-eat.PAST  
'I wasn't eating. / I used to not eat.'

In present tense, the negation and the imperfective prefixes fuse and become *na-*.

- (47) a. E dɪ-k-ɪm.  
1 SG.DIR IMPV-do-1 SG  
'I do.'
- b. E na-k-ɪm.  
1 SG.DIR NEG.IMPV-do-1 SG  
'I don't (do).'

In addition to the prefixes, the verbal complex can host two types of suffixes, agreement and a copula.

- (48) Ez d<sub>1</sub>-her-*im*-e.  
 1SG IMPF-go.PRES-1SG-COP.PRES  
 'I am going.'

On some occasions, the copula and the agreement morphemes are expounded as a single portmanteau morpheme, possibly a contraction.

- (49) a. T<sub>1</sub> d<sub>1</sub>-her-*i*-ye  
 2SG.DIR IMPF-go.PRES-2SG-COP.PRES  
 'You are going.'
- b. T<sub>1</sub> d<sub>1</sub>-her-ê  
 2SG.DIR IMPF-go.PRES-2SG.COP.PRES  
 'You are going.'

The Kurmanji verbal template is given in (50).

- (50) NEG-ASP/MOOD- $\sqrt{\text{root}}$ +TENSE-AGR-COP

The Kurmanji verbal complex has a number of idiosyncrasies. The fact that the verb root often fuses with the “tense” excluding aspect is a challenge for the compositional semantic analysis of verb-aspect-tense by Demirdache and Uribe-Etxebarria (2007) among others. Another idiosyncrasy is the Asp-V-T order which is rare according to Julien (2002). These observations are due to Kalin and Atlamaz (2015).

One last phenomenon that needs mention is the “lexical prefixes” that derive new verbs. Consider the following examples.

- (51) a. Mehemed ke-t.  
 Mehemed.DIR fall-PAST  
 'Mehmet fell.'
- b. Mehemed ra ke-t.  
 Mehemed.DIR RA fall-PAST  
 'Mehmet slept.'

The morpheme RA, when combined with the verb *ket*, “fell”, means “slept/fell asleep”. RA, by itself, does not mean “sleep”, though. For example, it can be used with the copula to mean “stood up /woke up” as in (52).

- (52) Mehemed ra wu.  
 Mehemed.DIR RA be.PAST  
 ‘Mehmet stood up / woke-up.’

What is significant is that negation and aspect intervene between this particle and the verb root.

- (53) a. Mehemed ra ne-ke-t.  
 Mehemed.DIR RA NEG-fall-PAST  
 ‘Mehemed didn’t sleep.’  
 b. Mehemed ra na-kev-ê.  
 Mehemed.DIR RA NEG.IMPf-fall-COP.PRES  
 ‘Mehemed isn’t sleeping.’

Before closing this subsection, let me provide the agreement paradigms for Kurmanji. Agreement morphemes are mostly the same across tenses and aspects, except for a couple of cases where alternations are phonological or morphologically conditioned. The agreement paradigms for present tenses are given below.

(54)

PERSON	simple present	present progressive	past simple
1SG	-(i)m	-(i)m	(i)m
2SG	-i	-ê	-i
3SG	-e	-ê	∅
1PL	-n(i)	-n(i)	-n(i)
2PL	-n	-n	-n
3PL	-n	-n	-n

One thing worth commenting on is the 1PL *-n(i)* morpheme. In general, plurality is expounded on the verb with the underspecified *-n* morpheme. However, when the verb agrees with 1PL, it can optionally expound the *-ni* morpheme which appears to be a combination of plural and first person.

### 4.3 Split Ergativity in Kurmanji

Recall that Kurmanji is a split ergative language in which alignment changes depending on the tense of a given clause. The alignment patterns are given in (55)

(55)	INTRANSITIVE	TRANSITIVE	CONDITION	(Atlamaz and Baker 2018)
	DIR	DIR – OBL	<i>present tense</i>	
	DIR	OBL – DIR	<i>past tense</i>	

The two main accounts of ergativity in the recent literature have been *Inherent Case* (Legate 2008; Woolford 1997) and *Dependent Case* (Baker 2015; Marantz 1991). Following Atlamaz and Baker (2018), I argue that split ergativity in Kurmanji is best accounted for by a theory of dependent case assignment. Let me start with the problems of an inherent case analysis.

The inherent case theory is based on the idea that ergative case is assigned by *v* along with  $\theta$ -role assignment. The earliest views restricted ergative to the Agent  $\theta$ -role but this restriction was loosened to capture other external arguments like causers, some experiencers, etc. The main proposal of the inherent case view is that ergative is inherent case assigned to external arguments by *v*. This is due to the lexical/inherent properties of *v*. This line of thought faces some challenges in accounting for split-ergativity in languages like Kurmanji.

First, the inherent case analysis predicts a difference between unergative and unaccusative subjects all things being equal. If the unergative subjects are external arguments, then the inherent case theory predicts them to get ergative case. This is not borne out in Kurmanji. Both unaccusative and unergative subjects get direct case in Kurmanji past tense clauses.

- (56) a. Ez/\*M<sub>1</sub>                      rwi-m.  
           1 SG.DIR/1 SG.OBL run.PAST-1 SG  
           ‘I ran.’
- b. Ez/\*M<sub>1</sub>                      ket-ım.  
           1 SG.DIR/1 SG.OBL fall.PAST-1 SG  
           ‘I fell.’

The facts in (56) indicate that ergativity is not related to having a certain type of  $\theta$ -role

or just being the external argument. Instead, ergativity in Kurmanji requires at least two arguments, which I call the transitivity requirement.<sup>5</sup> This is a mirror image of Burzio's Generalization given in (57).

- (57) *Burzio's Generalization* (Burzio 1986, p. 178)  
 All and only the verbs that can assign a  $\theta$ -role to the subject can assign Accusative Case to an object.

In Kurmanji, Burzio's generalization can be restated as the Ergativity Generalization as in (58) which can be reduced to the Transitivity Requirement given in (59).

- (58) *Ergativity Generalization in Kurmanji*  
 All and only the verbs that can assign a  $\theta$ -role to the **object** can assign **Ergative** Case to a **subject**.
- (59) *Transitivity Requirement in Kurmanji*  
 Ergative case can be assigned only in transitive clauses.

The Transitivity Requirement by itself is not a big challenge for the inherent case theory. One could argue that only transitive verbs assign ergative case to their external arguments. This can still account for ergativity in straightforward ergative languages. What is more challenging is the split ergativity which is further conditioned by Aspect in many languages (Coon 2013) and by Tense in Kurmanji. Ergative alignment is limited to transitive past tense clauses in Kurmanji. Transitivity by itself is not enough for ergative alignment. In order for the inherent case theory to work, it needs to make reference to both the transitivity of *v* and the tense information presumably coded on a different head in the clause. As far as I can see, this voids the "inherent" nature of inherent case assignment. Case assignment needs to make reference to different structural configurations in a clause (both transitivity and tense) which makes it structural rather than inherent.<sup>6</sup>

<sup>5</sup>Akkuş (to appear) observes that the transitivity requirement is a general condition across Kurmanji and Zazaki dialects. Akkuş (to appear) expresses it as the transitivity condition which I modify here as the transitivity requirement.

<sup>6</sup>See Akkuş (to appear) for a novel model of inherent case assignment based on Svenonius (2006). In this model, inherent case is assigned by a chain established between different heads (*v/Voice* and T) in the syntax.

Now, let us see how a configurational theory of case assignment can account for Kurmanji split ergativity. The first point to account for is the transitivity requirement on ergativity. In Marantz's Dependent Case view, this is captured naturally as ergative is a dependent case and it can be assigned only when a case domain has at least two arguments. This is why, in Kurmanji, intransitive subjects never get ergative regardless of their  $\theta$ -role. Following Baker's (2015) interpretation of configurational case assignment based on Marantz (1991), I propose that Kurmanji case facts can be accounted by the case assignment rules given below.<sup>7</sup>

(60) *Kurmanji Case Rules*

- a. DEPENDENT  
If NP1 c-commands NP2 when TP is spelled-out, assign NP1 OBL.
- b. DEFAULT  
If NP has received no other case when a VP is spelled-out, assign NP OBL.
- c. UNMARKED  
Otherwise, do nothing.

The case rules above make reference to two case assignment mechanisms from Marantz (1991) with some significant differences. The first difference is about the dependent case assignment mechanism. For Marantz, the local domain for dependent case assignment is  $v+T$ , which corresponds to the clause. Following Baker (2015), I take case domains to be spell-out domains of phases; TP for the CP phase and VP for the  $vP$  phase.

The second difference is a terminological shift with some theoretical significance. Marantz makes a distinction between UNMARKED case and DEFAULT case. UNMARKED case refers to the *elsewhere* case in a particular domain while DEFAULT case is the *elsewhere* case that is not domain sensitive. For example, for Marantz, nominative is the UNMARKED case in TP while genitive is the UNMARKED case in DP. Baker (2015) extends this to accusative in VP (also partitive in VP in Finnish). While the distinction between Marantz's UNMARKED and DEFAULT

---

This model has the potential to account for the transitivity requirement as well as the tense conditioning.

<sup>7</sup>See Atlamaz and Baker (2018) for a slightly different version of (60).

cases is clear, I argue that the distinction is minor and possibly unnecessary. Marantz's UN-MARKED case is just a DEFAULT case further restricted by the environment. Hence, a DEFAULT case mechanism with a possibility of further domain restriction should suffice to capture both domain specific and domain general defaults.<sup>8</sup>

The third significant difference is about (60-c). The rule is only descriptive and does not really exist. UNMARKED in (60-c) refers to the absence of case. Following Kornfilt and Preminger (2015), I assume that nominals without overt case (paradigmatically) do not have any case. Structurally, they are not KPs.<sup>9</sup>

The case assignment rules in (60) account for oblique case on subjects (ergative) and the absence of case on intransitive subjects. As will be clarified in the following, they also account for the oblique case on objects in present tense clauses. The question that remains to be answered is the source of split ergativity.

Recent work on split-ergativity has tied it to the presence/absence of clausal bifurcations (Baker 2015; Coon and Preminger 2017; Kalin and van Urk 2015). Assuming that ergative case is the dependent case assigned to the higher of the two arguments in a domain, the presence of a clausal bifurcation which divides the clause into two separate case domains prevents dependent case assignment. When the clausal bifurcation is removed, the two NPs are in the same case domain, making dependent case assignment possible. For Baker (2015), the head that is responsible for determining the clausal bifurcation is *v* which may or may not be a phase head. When *v* is a phase head, it creates two independent case domains bleeding dependent case assignment. When *v* is not a phase head, both arguments are in the same phase making dependent case assignment possible. For Coon and Preminger (2017), the head that is responsible for the clausal bifurcations is Asp. Imperfective aspect is universally more complex than perfective aspect and it adds extra structure potentially creating a clausal bifurcation. This extra structure is not present in perfective clauses which makes dependent case assignment possible. This is why a large amount of split ergativity is

---

<sup>8</sup>Nothing really hinges on the unification of the two case mechanisms. It is just an argument of parsimony. My proposal still works if the two case mechanisms can be proven to be distinct.

<sup>9</sup> Whether a nominal has case or not can be identified paradigmatically. For example, in Tsez and Laz, first and second person pronouns do not seem to have overt case. Only third person pronouns tell whether a given pronoun is totally caseless or has ergative/dative/etc. Whether a nominal that lacks overt case marking is an NP or a KP can be identified paradigmatically, by considering all the nominals in that paradigm. See Chapter 3 Section 1 for discussion.

aspect based.

Following Baker (2015) and Coon and Preminger (2017), I argue that the split-ergativity in Kurmanji is due to the presence/absence of clausal bifurcations in the clause. In particular, I adopt Baker's view that the phasal status of *v* determines the split. In present tense clauses, *v* is a phase head and spells-out its VP complement. This prevents dependent case assignment resulting in nominative-accusative (DIR-OBL) pattern. The internal argument receives oblique case by (60-b). In past tense clauses, *v* is not a phase head. Hence, the two NPs are in the same case domain which yields dependent ergative case on the subject.

The main question that needs an answer is the conditioning factor of split-ergativity in Kurmanji. In particular, if *v* is the head that determines phasehood, how does Tense determine the status of *v*, especially given that Aspect can intervene Tense and *v*? Why is *v* a phase head in present tense clauses and why is it not a phase in past tense clauses? Also, it has been argued that cross-linguistically, all the split ergativity (except for person splits) is due to aspect splits, not tense splits (Coon 2013; Salanova 2007). Why is Kurmanji an exception (along with some other Iranian languages)?

To understand the source of split-ergativity, let us take a closer look at the conditioning factors of ergativity in Kurmanji. To my knowledge, the first argument regarding Kurmanji being a tense split but not an aspect split was presented by Gündoğdu (2011). She showed that ergativity is not correlated with the presence/absence of the imperfective morpheme *di-*.<sup>10</sup>

- (61) a. Ez        nêñ        dı-k-ım.  
           1SG.DIR bread.OBL IMPF-do-1SG  
           'I make bread.'
- b. Mı        nan        dı-kır.  
           1SG.OBL bread.DIR IMPF-do.PAST-1SG  
           'I was making bread; I used to make bread.'

Both (61-a) and (61-b) are imperfective but (61-a) has an accusative alignment while

<sup>10</sup>Gündoğdu (2011) glosses *di-* as progressive aspect. Progressive is not the right gloss for *di-* as it does not necessarily encode progressive aspect. In fact, in (61-a), it encodes habitual/repetitive events. To make (7-a) progressive, Kurmanji adds the copular suffix *-e* after the agreement morpheme along with the imperfective *di-* prefix. See (33) for examples.



(61-b) has an ergative alignment. The main interpretational difference between the two clauses is a difference in the temporal relation between the event time and the utterance time. Putting aside the case and agreement differences, the other difference between the two clauses is the shape of the verbal stem that consists of the verbal root and some sort of morphology that correlates with the temporal relation between the event time and the utterance time. Gündoğdu (2011) takes this as evidence to argue that Kurmanji has a tense split rather than an aspect split.

While (61) shows that Kurmanji is not a language where viewpoint aspect conditions the alignment split, it does not prove that Kurmanji is not an aspect split. Neither does it prove that it is a tense based split. The conditioning factor in the alignment differences in (61) is the stem, which consists of the verbal root and some functional head which correlates with tense information. It is this functional head that determines the split ergativity in Kurmanji. In present tenses, this head is  $\emptyset$  while in past tense clauses this head appears as *-i* or *-t* as well as some other irregular and suppletive forms. The stem dependency occurs in a wide range of split ergative Iranian languages according to Haig (2008). In Kurmanji, it is this head that forms stems which is responsible for the clausal bifurcations. What is the nature of this stem forming head? Does it encode tense or something else? Is the *-i* (or *-t* morpheme) found in past tense clauses a past tense morpheme?

Kalin and Atlamaz (2015) show that the *-i/-t* morpheme is not really a past tense morpheme as it can appear in contexts without past tense meaning. The two contexts they consider are participles and nominalizations. Kurmanji uses the past stem in adjectival participles and nominalizations but not the present stem. The participles are constructed by adding an extra adjectival participle suffix *-i* on the past stem as in (62).

(62) isot-ê      dagır-t-i  
 pepper-EZ pickle-PAST-ADJ.PART  
 'pickled pepper'

The participle in (62) does not (necessarily) encode past tense information. While *pickled peppers* imply peppers being pickled before the utterance time, past tense is not entailed. This is supported by the possibility of (63) where the event of pickling happens at a time

after the utterance time.

- (63) Em dıke isot-ê dagır-t-i bı-k-ını.  
 1PL.DIR will pepper-EZ pickle-PAST-ADJ.PART SBJN-do-1PL  
 ‘We will pickle peppers.’ Lit: We will make pickled peppers.

The other example comes from nominalization which is established by adding the *-ın* suffix on the past stem. Like in adjectival participles, past information is not entailed by the past stem in nominalizations. For example, in (64), the nominalized verb does not have a past meaning.<sup>11</sup>

- (64) Em dıke rıv-i-n-ê Mehemed-ê temaşe bı-k-ını  
 1PL.DIR will run-PAST-NMLZ-EZ Mehmed-OBL spectacle SBJN-do-1PL  
 ‘We will watch Mehmet’s running.’

The sentence in (64) is felicitous in conditions where Mehmet has already run and the event was recorded or Mehmet hasn’t run yet and will run in the future.

The past stem can also be used in immediate future contexts without any past tense entailment or implication. For example, in response to (65-a), the clause in (65-b) is felicitous without any past tense information.

- (65) a. Hadi lo Mehemed-o. Dereng-e.  
 come-on VOCATIVE Mehemed-VOCATIVE late-COP  
 ‘Come on Mehemed. We’re late./It’s late’  
 b. Hat-ım.  
 come.PAST-1SG  
 ‘I’m coming. Lit: I came.’

The facts above raise two questions: i) if the morpheme *-i/-t* is not a past tense morpheme, then what is it?, ii) where does the past tense information in past tense clauses come from? I argue that the morpheme *-i/-t* is the P-PARTICIPLE and the past tense information comes from the *perfect* construction, a complex syntactic structure.

P-PARTICIPLE refers to the past participle which is also called the perfective participle or the passive participle in many languages. The term P-PARTICIPLE was coined by Stowell

<sup>11</sup>This observation is due to Kalin and Atlamaz (2015)

(2008) as a neutral term that can capture both the past and passive natures of participles. Pointing out the fact that, in languages like French and Austrian German, the perfect construction is the standard tense/aspect form used to report past-time events, Stowell proposes that the past-tense information in perfect clauses comes from “constructions” that include an auxiliary and a participle.

Stowell (2008) shows that the past tense information does not come from the auxiliaries like *have/be*. For example, in English, perfect constructions can denote immediate past as in (66).

(66) I have just seen Bill.

While (66) has an immediate past information. The verb *have* does not have the past tense information by itself in other constructions like (67).

- (67) Uses of *have* in English (Stowell 2008)
- a. Max {has/had/will have} blue eyes. (inalienable possession)
  - b. Brent {has/had/will have} the car today. (temporary possession)
  - c. Janet {has/had/will have} to leave early. (modal necessity)
  - d. Karen {had/will have/?has} the tenants evicted. (causative passive) The car has a wheel loose. (circumstantial)

Stowell (2008) also shows that past tense information is not encoded by the P-PARTICIPLE either. When the P-PARTICIPLE is used outside the perfect constructions, it has *passive* properties without any past tense information. Some examples from Stowell (2008) are given below.

- (68)
- a. Karen’s tenants will be evicted by her.
  - b. Karen will have her tenants evicted.
  - c. Any tenant evicted by Karen should take swimming lessons.

In (68-a) and (68-b), p-participle does not provide any past tense information. (68-c) can

have a past tense interpretation but it is not obligatory. It is possible to use (68-c) in a context where Karen did not evict any tenant at all and the sentence has a generic or a future time reference. Stowell uses this as evidence to argue that the P-PARTICIPLE is not intrinsically past-tense encoding. The past-tense information is established as a result of the combination of an auxiliary (*have/be*) and a P-PARTICIPLE in the same clause. How does this work?

Zagona (1990) proposed that tenses are dyadic predicates that take the event time (ET) as a complement and the utterance time (UT) as its specifier as in (69). The tense predicate orders ET and UT with respect to each other.

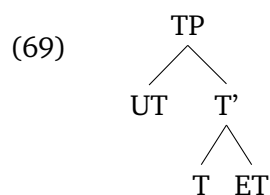

Following Larson (1988), Stowell analyses the dyadic Tense predicate as two monadic tense phrases consisting of a TP and a *tP*.<sup>12</sup> The proposed structure is (70), in which past meaning is established through the interaction of two temporal heads *t* and T, both of which introduce a temporal argument.

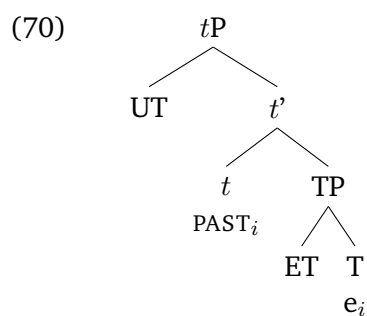

The structure in (70) provides Stowell a syntactic basis for analyzing the past tense meaning in perfect constructions. The auxiliary *have* occupies the *t* position while the lower

<sup>12</sup>This is in the same line as Borer (2004) among others in the sense that each argument is introduced by one functional head.

T position hosts the participle forming head *-en*. This is shown in (71).

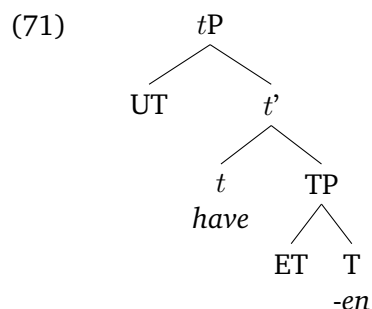

In (71), TP is headed by *-en* which detransitivizes the verb, resulting in the passive nature of the P-PARTICIPLE outside the perfect constructions. The external argument is introduced by *have*. Once TP which introduces the ET argument combines with *tP* which introduces the UT argument, past meaning is established.

Following Stowell’s proposal regarding the complex temporal structure of perfect clauses, I argue that Kurmanji “past tense” clauses have a complex temporal structure akin to perfect clauses in many Indo-European languages like English, French, Austrian German, etc. The only difference is that Kurmanji lacks an overt auxiliary like *have*.<sup>13</sup> Slightly diverting from Stowell’s proposal, I propose that the temporal structure of a simple “past tense” clause in Kurmanji is as in (72).

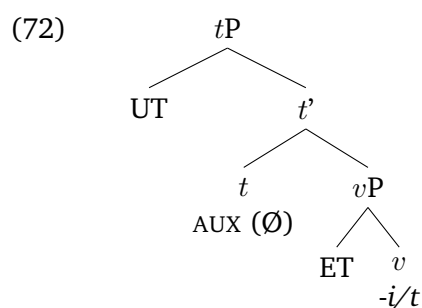

The participle forming head is introduced by *v*, which also introduces an event time

<sup>13</sup>Kurmanji does not have the verb *have* anyway. Possession denoting clauses are established via nominal possession constructions plus the verb *hebun* “to exist”. See Baker and Atlamaz (2014) for a slightly different proposal about the silent auxiliary in Kurmanji.

argument. When combined with a *tP*, which hosts the silent auxiliary like *have* in English and *have/be* in Austrian German, the clause has a past interpretation. In other situations, the P-PARTICIPLE which consists of the verbal root and the *-i/t* suffix on *v* does not get a past interpretation. Instead, it gets a passive interpretation just like in English.

Ergativity in Kurmanji is caused by the participle forming *v* head *-i/t*. The *v* in past tense clauses is not a phase head because it is passive in nature. On the other hand, in present tense clauses, *v* does not create a participle and it is active. Chomsky (2000, 2001) proposed that active *vs* are phase heads (*v\**) while passive and unaccusative *vs* are not. Since the participle form of the verb that appears in past tense clauses has a passive nature, it does not form a phase head resulting in dependent case assignment. In present tense clauses, *v* is a phase head and creates a clausal bifurcation that prevents dependent case assignment. This creates an accusative alignment. Given that *v* is responsible for the split ergativity in Kurmanji, it is false to categorize Kurmanji as an Aspect split or a Tense split. Kurmanji is a *v*-split which aligns well with the Phase Theory. The proposal that *v* is a phase head in present-tense clauses but not in past-tense clauses also captures object agreement facts discussed in Section 7.<sup>14</sup>

Before closing this section, let me present a few more arguments about past stems, which are P-PARTICIPLES, being passive. We have already seen some evidence in (62) indicating past stems being passive. *isote dagirti* “pickled peppers” is an example where the participle has an internal argument but not an external argument. Participles of transitive verbs cannot have external arguments and always get a passive reading. For example, in (73), the modified noun must be the internal argument but cannot be the external argument.<sup>15</sup>

- (73) beq-ê kuş-t-i  
 frog-EZ kill-PAST-ADJ.PART  
 ‘the killed frog’ (the frog is dead, passive interpretation)

Not: ‘the frog which killed x’ (active interpretation) (Baker and Atlamaz 2014)

<sup>14</sup>I have explored this passive hypothesis in Atlamaz (2012), primarily following Trask (1979) who argues that cross-linguistically, there are two sources of ergativity, one of which is historically passive constructions. In Baker and Atlamaz (2014) and Atlamaz and Baker (2018), we proposed a phase based explanation for the passive hypothesis.

<sup>15</sup>The adjectival participle constructions are not very tolerant to typical agents. For example, *merikê kuşti* “the killed man” is marginal although *merik* “man” can be a theme in a transitive clause.

The past stem is also used in nominalizations as in (74).

- (74) Kuşt-in-a beq-ê nê rind-e.  
 kill.PAST-NOML-EZ frog-OBL not good-COP.PRES  
 ‘To kill (the) frog is not good.’ (Lit: ‘The frog’s killing is not good.’)  
 Not: ‘For the frog to kill is not good.’ (Baker and Atlamaz 2014)

Nominalization in Kurmanji allows the internal argument to be expressed as a possessor whereas external arguments are not allowed. So, in (74), “frog” can be interpreted as the theme argument but not the agent argument. This is another indication of the passive behavior of the “past stems” in Kurmanji.

Another construction that uses the “past stem” is the periphrastic passive construction in Kurmanji. Like in English, these constructions are used when the external argument is unknown or unimportant. They are formed by using the nominalized form of the verb as a location argument of the verb *hatin* “to come”. The theme appears as the subject of the clause.

- (75) Xanî hat frot-in-ê.  
 house.DIR came sell.PAST-NOML-OBL  
 ‘The house was sold.’ (Lit: ‘The house came to selling.’) (Baker and Atlamaz 2014)

Again, the past stem has a passive interpretation but not an active interpretation. The past stem receives an active interpretation only when it gets the “past tense” interpretation in the perfect construction.

Further support for the passive nature of the past stem comes from historical analyses of Iranian languages. Haig (2008) argues that past stems in Iranian languages come from resultative participles in Old Iranian. These participles could not have accusative objects, could be predicated of theme subjects, and could realize the thematic agent as a genitive clitic. The past tense form in Old Iranian was lost diachronically and the participle constructions became the only way of expressing past tense. Similar arguments have been proposed by Dorleijn (1996) who argues that past stems are passive like. In a similar line, Kalin and

van Urk (2015) argue that the Neo-Aramaic language Senaya, a split ergative language, has an “inactive” *v*.

To sum up this section, I have argued that the split ergative case facts in Kurmanji can best be accounted for by a configurational theory of case. In particular, I propose that ergative case in Kurmanji is the dependent case assigned when two NPs are in the same phase. In present tense clauses, the *v* is active and introduces a phase head which divides the clause into two separate case domains resulting in an accusative alignment. In past tense clauses, which are perfect constructions with a P-PARTICIPLE, *v* is passive and does not introduce a phase boundary. As a result, the two NPs in a transitive clause are in the same case domain resulting in dependent ergative case on the subject. This account captures the uniform treatment of the sole arguments of unergative and unaccusative verbs. Given that they are the sole argument in a clause, they never get ergative case. Finally, I have argued that Kurmanji is neither an aspect split nor a tense split. Instead, it is a *v*-split and confirms the predictions of the Phase Theory.<sup>16</sup>

A final note is about the order of operations. I assume that lexical case and dependent case are assigned before agreement. This is the standard assumption for lexical case. Baker (2015), Bobaljik (2008), and Preminger (2014) make the same assumption for dependent case. Now that I have clarified my assumptions regarding case assignment in Kurmanji, I move on to partial agreement with oblique subjects in Kurmanji.

## 5 Accounting for Kurmanji Partial Agreement

As described in Section 4, Kurmanji displays all the three logical possibilities of agreement with a nominal. Morphologically unmarked nominals are fully agreed with in person and number. Oblique first and second pronouns cannot be agreed with at all. Other oblique nominals are agreed with in number. The generalization is given in (76).

---

<sup>16</sup>Stowell (2007) treats perfect as aspect. If the participle forming head is an aspect head, then Kurmanji should be treated as an aspect split conforming to the claims of Coon (2013) and Salanova (2007).



(76)	SUBJECT	AGREEMENT
	DIRECT	PERSON & NUMBER
	3.OBL	NUMBER
	1/2.OBL	NO AGREEMENT

Accounting for the Kurmanji facts summarized in (76) can provide us with a theory that can capture some of the cross-linguistic variation in agreement with an overtly case marked nominal. Given the hypotheses provided in Section 3.2 repeated below for convenience, the variation in Kurmanji should follow from the properties of the goals or the probes.

(77) **Hypothesis I** – Different Goals

Cross-linguistic variation in agreement is due to the differences in the structures of goals.

(78) **Hypothesis II** – Different Probes

Cross-linguistic variation in agreement is due to the differences in the structures of probes.

Kurmanji facts indicate that Hypothesis II cannot be maintained as a complete theory. There is no evidence that the difference in agreement patterns in Kurmanji is a result of different  $\varphi$ -probes. In both past and present tense clauses, the verb can show full person and number agreement. For example, (80) is a present tense clause where T agrees with the direct case subject in person and number.

(79)	Ez	te	di-vun-im-e.	
	1 SG.DIR	2 SG.OBL	IMPF-see-1 SG-COP	
	'I see you.'			Atlamaz and Baker (2018)

(80) is a past tense clause where T agrees with the morphologically unmarked object in person and number.

(80)	Te	ez	di-m.	
	2 SG.OBL	1 SG.DIR	see-.PAST-1 SG	
	'You saw me.'			Atlamaz and Baker (2018)

In both (80) and (80), T can agree with first and second person pronouns in number and gender as long as they are not oblique. I take this to be evidence that the  $\varphi$ -probe in all Kurmanji clauses is one and the same. The variation is due to the properties of goals. Agreement correlates with the case and  $\varphi$ -features on the goals. This supports Hypothesis I. In the following, I provide a theory that accounts for the Kurmanji agreement facts within the tenets of Hypothesis I.

### 5.1 Phi-visibility and Case Marking

Why does overt case disturb agreement in many languages? For this, I assume that nominals with overt case are structurally more complex than nominals without any overt case. In particular, following Bittner and Hale (1996) and Lamontagne and Travis (1986), I assume that overtly case marked nominals are KPs while morphologically unmarked nominals (nominative, absolutive, direct. etc.) are caseless and they lack the extra K structure.<sup>17</sup> Caseless nominals have the structure in (81-a) while case marked nominals are as in (81-b).

(81) a. Caseless NP



b. Case-marked NP

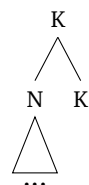

The KP assumption is also supported by Kurmanji facts. Kurmanji is a dominantly head final language and case appears as a suffix attached to nominals.

(82)	<b>NOUN</b>	<b>DIRECT</b>	<b>OBLIQUE</b>
	girl	keçık	keçık-ê
	book	kitaw	kitaw-ê
	Eşxan	Eşxan	Eşxan-ê

<sup>17</sup>The claim that nominative NPs are caseless have been independently proposed by Kornfilt and Preminger (2015). Marantz (1991) has shown that Abstract Case is not required to license nominals. Nominal licensing is basically controlled by  $\theta$ -Theory (though, see Chapter 4 for a theory of nominal licensing). If Abstract Case is not required, then nominative is a superfluous term. There is no need to assume that nominals without overt case have case.

Following Atlamaz and Baker (2018), I argue that, in many languages, K disturbs agreement because only the features at the top of a nominal phrase are accessible for agreement purposes. This is stated in (83).

(83) *Accessibility of  $\varphi$*

Only features at the topmost layer of a nominal are accessible for agreement operations.

(84) *Case-marked NP*

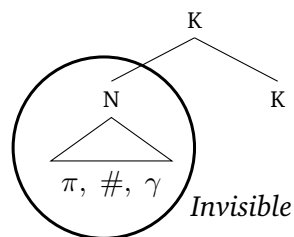

When a nominal gets case, it is encapsulated under a KP which hides all the  $\varphi$ -features from agreement. This is why in many languages<sup>18</sup> overt case blocks agreement totally, yielding no agreement with overtly case marked nominals.<sup>19</sup> This can be expressed in the form of a generalization as in (85).

(85) *K blocks Agree*

In languages where Agree is case-sensitive, overt case blocks agreement.

In Section 5.3, I derive the generalization in (85) from the definitions of probes, goals, and Relativized Minimality. The generalization in (85) captures a broad range of languages but not Kurmanji. Kurmanji is also a language in which agreement is sensitive to case but the blocking effect is only partial. While oblique case blocks agreement with participant

<sup>18</sup>See Section 6.1 for an account of Hindi.

<sup>19</sup>In a sense, this is similar to the impossibility of agreement with an NP buried inside a PP. Yet, there are certain differences. PPs block agreement probably because they are phases. Although it has been argued that KPs are phases, too, I am agnostic in terms of their phasal status. The current proposal derives the impermeability KPs through Relativized Minimality (Rizzi 1990). In many languages (Turkish, Laz, Nepali, etc.) case does not block agreement. This indicates that KPs are not phasal at least in some languages.

pronouns, it does not block agreement with common nouns or third pronouns. What is special about third nominals, such that overt case does not block agreement?

The morphological details of third oblique nominals in Kurmanji are revealing. Like in many Indo-European languages (Halle and Marantz 1993), NUMBER fuses with case under certain circumstances. Both plural and singular forms of direct common nouns are the same. The distinction is possible thanks to number agreement on the verb.

- (86) a. Keçik hat.  
 girl.DIR come.PAST  
 'The girl came.'
- b. Keçik hat-in.  
 girl.DIR come.PAST-PL  
 'The girls came.'

In oblique common nouns, number fuses with case yielding the portmanteau morpheme *-a*.

- (87) a. Keçik-ê nan xar.  
 girl-OBL bread.DIR eat.PAST  
 'The girl ate (bread/meal).'
- b. Keçik-a nan xar-in.  
 girl-PL.OBL bread.DIR eat.PAST-PL  
 'The girls ate (bread/meal).'

The same *-a* morpheme appears on third plural pronouns as well.

- (88) a. W-ê nan xar.  
 3-OBL bread.DIR eat.PAST  
 'She ate (bread/meal).'
- b. Wan-a nan xar-in.  
 3PL.OBL bread.DIR eat.PAST-PL  
 'They ate (bread/meal).'

Plural agreement with an oblique nominal is possible only when the nominal ends with *-a*. This contrasts with first and second person oblique pronouns where *-a* does not appear.

(89)	PERSON	SINGULAR		PLURAL	
		DIR	OBL	DIR	OBL
	1	ez	m- <i>in</i>	em	<i>m-e</i>
	2	t <sub>i</sub>	t- <i>e</i>	un	<i>w-e</i>

Second person direct pronoun is *ti* and it contrasts with the oblique form *te*. The difference between direct and oblique pronoun is the change in the vowel *-e*. Comparing second singular oblique with second plural oblique, we observe that *-e* remains constant while *t* changes to *w* indicating a fusion of number and person excluding oblique case.

Next, we can compare a second person plural oblique pronoun *we* with first person plural oblique pronoun *me*. Again, *-e* remains constant while the consonant becomes *m*. Except for 1SG.DIR, which I take to be total suppletion, all the first person pronouns have *m* in common. I take the patterns above to be an indication that in local pronouns nothing fuses with case (i.e. oblique K head). Crucially, in local pronouns, we don't observe the *-a* morpheme, which is an indication of the NUM+K fusion. As a result, in oblique local pronouns the topmost layer of the nominal is a K phrase which hosts only the case features but no phi features.

There are, not surprisingly, irregularities in the pronoun paradigm in Kurmanji. For example, the first person singular oblique pronoun is *m-in*. It is plausible to argue that *-m* is the morpheme for first person but it is not clear whether *-in* is the oblique case or something else. I take *-in* to be a contextually determined allomorph of oblique. The Vocabulary Insertion rules for case morphemes below captures the crucial facts.

(90)	<i>Kurmanji Case Rules</i>
	K $\longleftrightarrow$ <i>-in</i> / 1SG
	K $\longleftrightarrow$ <i>-e</i> / PARTICIPANT
	K $\longleftrightarrow$ <i>-ê</i> / elsewhere

The fusion of number and case is inserted by another rule given in (91).

(91)	K+NUM $\longleftrightarrow$ <i>-a</i>
------	---------------------------------------

To sum up the Kurmanji facts, in NPs and third pronouns, number and K fuse into a single

morpheme (-a) yielding number agreement with oblique plurals. On the other hand, in local pronouns, nothing fuses with K and there is no agreement with local pronouns, neither in person nor in number. Partial agreement with non-local oblique nominals is then possible as a result of the fusion processes. Features that fuse with K appear at the topmost layer of a nominal and can be agreed with. The execution of this idea requires a theory of fusion that generates the nominal patterns in Kurmanji and a theory of agreement that is sensitive to fusion. The next subsection provides an account of fusion patterns in Kurmanji. Once fusion patterns are accounted for, Section 5.3 presents a theory of agreement that is sensitive to fusion patterns.

## 5.2 Fusion in Kurmanji

In the previous section, I have shown that number (plural in particular) fuses with oblique case in non-local pronouns. Why does number fuse with K in third person nominals but not in local pronouns? I argue that number in Kurmanji is “weak” and it needs to fuse with something. This something is usually the closest head that c-commands number. To show this idea more explicitly, let me spell out my assumptions regarding the structure of pronouns and other nominals. Following Harley and Ritter (2002), I assume that  $\varphi$ -features are hierarchically organized inside the nominal as shown in (92).

(92) Organization of  $\varphi$ -features

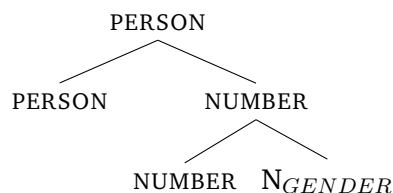

More specifically, I assume that local pronouns have a PARTICIPANT head which is missing in non-local nominals. The relevant syntactic structures of local pronouns and non-local nominals are as in (93).

(93) a. Local pronoun (1/2)

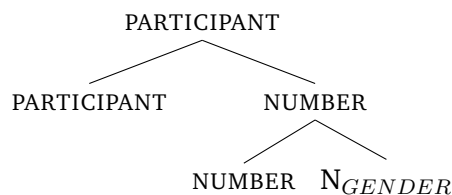

b. Other nominal

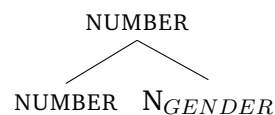

It should be noted that these are the structures for caseless nominals. Oblique nominals have an extra layer of K. The structures of oblique nominals in Kurmanji are given below. The heads are on the right as Kurmanji is a head final language.

(94) a. Oblique Local Pronoun

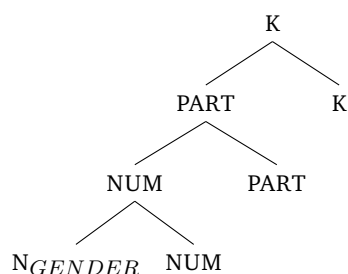

b. Oblique Non-local Nominal

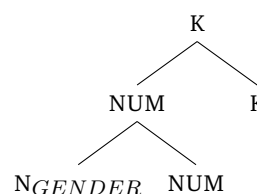

At PF, these structures are fed into the operation Fusion (as well as other morphological operations). Fusion is a post-syntactic operation that can alter the syntactic structure in a limited way. The definition of Fusion is as in (95).

(95) *Fusion*

(Halle and Marantz 1993)

Fusion is a post-syntactic (Distributed Morphology) operation that combines two (structurally) adjacent heads into one without any internal structure.

The result of Fusion is a single locus for Vocabulary Insertion, yielding portmanteau morphology. The Kurmanji-specific fusion rule is given in (96).

(96) *Kurmanji Fusion Rule for Number*

Fuse NUM with the closest c-commanding head.<sup>20</sup>

<sup>20</sup>The Kurmanji Fusion Rule is stated as a context-free recursive rule and it has the potential to cause an

The Kurmanji Fusion Rule for Number takes as input the structures in (94) and returns the structures in (97) as output.

(97) a. Local Oblique Pronoun

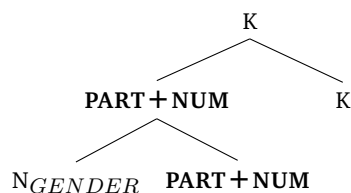

b. Non-local nominal

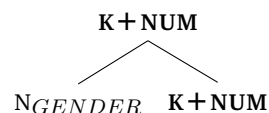

In (94-a), PART head is the closest head c-commanding NUM. Thus PART and NUM fuse below K resulting a non-agreeing oblique local pronoun as in (97-a). In (94-b), the K is the closest head c-commanding NUM. Thus, PART and NUM fuse resulting in an oblique nominal that can be agreed with in number as in (97-b).

One question that raises is the following: What happens when there is no head c-commanding NUM inside the noun phrase? I argue that nothing happens. Such cases are direct third person pronouns and direct NPs. This is supported by the fact that in Kurmanji direct nominals, number is not visible at all. Singular and plural nouns have the same form as show in (86). The table below illustrates all the relevant fusion patterns in Kurmanji nominals.

(98)

	PRE-FUSION	POST-FUSION	PRODUCT	AGREEMENT	EX.
a.	[[NUM] PART]	[NUM + PART]	1/2.DIR	{person, number}	(33)
b.	[[[NUM] PART] K]	[[NUM + PART] K]	1/2.OBL	{ }	(36)
c.	[NUM]	[NUM]	3.DIR	{number}	(35-e)
d.	[[NUM] K]	[NUM + K]	3.OBL	{number}	(37)

infinite loop. As it stands, there seems to be nothing that limits number to keep fusing with the c-commanding heads. I assume that the output of Fusion is a complex object that is no longer a NUM but a combination of NUM and some other head. I argue that recursive fusion is prevented by some principle that prevents a rule specified for a certain feature to apply to a structure that contains more than just the specified feature. This is akin to the Subset Principle (Halle and Marantz 1993) (see (132)). I argue that the Fusion Rule in (96) cannot apply to its output as it is a proper superset of NUM. See Atlamaz and Baker (2018, p. 209) for an alternative.



### 5.3 A Theory of Morphology-sensitive Agreement

The main generalization established in the previous section has been that agreement in Kurmanji is sensitive to the output of Fusion. Given that Fusion is a Distributed Morphology operation (Halle and Marantz 1993) that applies post-syntactically, agreement must be post-syntactic. This, however, is in tension with a wide range of claims about agreement being the result of a syntactic operation (Agree) (Baker 2008; Béjar and Rezac 2009; Chomsky 2000, 2001; Preminger 2014). One argument in favor of agreement happening in the syntax is locality. As will be discussed in the next section, and has been argued independently, Agree is constrained by syntactic locality domains like phases. The question is then this: What kind of a theory is needed to capture Kurmanji facts where agreement is sensitive to both syntactic and post-syntactic constraints?

Kurmanji facts indicate that agreement is not the result of a single operation; instead, it is the overall output of a syntactic operation and a post-syntactic one the latter of which is sensitive to Fusion. The idea that Agree is a two step process is not new. Arregi and Nevins (2012), Bhatt and Walkow (2013), and Marušič, Nevins, and Badecker (2015) argued that Agree consists of two operations, *Agree-Link* and *Agree-Copy* (the terminology belongs to Arregi and Nevins (2012)). The main focus of previous work on two-step agree has been mostly been on agreement into conjuncts. The main argument comes from closest conjunct agreement where agreement seems to be linear while still being restricted by some hierarchical constraints. For example, for Marušič, Nevins, and Badecker (2015), *Agree-Link* applies in the syntax while *Agree-Copy* applies post syntactically after *flattening* and *linearization*.

(99) Agree-Link  $\prec$ <sup>21</sup> Flattening, Linearization  $\prec$  Agree-Copy

In fact, for Marušič, Nevins, and Badecker (2015), the ordering of operations is parameterized. When *Agree-Copy* applies after *Flattening* and *Linearization*, closest conjunct agreement occurs; when it applies before *Flattening* and *Linearization*, highest conjunct

---

<sup>21</sup>precedes

agreement occurs.

Following Arregi and Nevins (2012), Atlamaz and Baker (2018), Bhatt and Walkow (2013), and Marušič, Nevins, and Badecker (2015), I assume that agreement is a two-step operation. I also adopt the terminology Agree-Link and Agree-Copy. The main contribution is that Agree-Copy applies after the PF operation Fusion. The order of relevant operations is as in (100).

(100) Agree-Link  $\prec$  Fusion  $\prec$  Agree-Copy

However, Bhatt and Walkow (2013) and Marušič, Nevins, and Badecker (2015) do not provide definitions of Agree-Link and Agree-Copy. In this section, I provide definitions of these operations which makes the analysis of Kurmanji partial agreement facts possible. Let me spell out the details of the proposal. The objects upon which agreement relations are established are “probes” and “goals”. Any theory of agreement must have definitions of these grammatical objects (or equivalents). The definitions that I propose are given in (101).<sup>22</sup>

- (101) a. **Probe:** A  $\varphi$ -probe P is a (functional) head with unvalued  $\varphi$ -features that needs a goal G with matching  $\varphi$ -features to get its features valued.
- b. **Goal:** A goal G is a maximal extended projection identified by the  $\varphi$ -features of a probe.

The definition of a goal is contingent on the definition of a probe. Goals in a given language are characterized by the nature of probes in that language. Similarly, the definition of a probe is contingent on the unvalued  $\varphi$ -features on a probe. Generally,  $\varphi$ -features are assumed to be PERSON, NUMBER, and GENDER features, which are interpretable on goals rather than probes. Languages differ in which features they employ on probes. For example probes in languages like English and Turkish come with PERSON and NUMBER features while in Hindi probes have GENDER features. In Kurmanji, probes in verbal clauses have PERSON

---

<sup>22</sup>The definitions here are slightly modified versions of the definitions we provided in Atlamaz and Baker (2018). The definition of a goal is more general here.

and NUMBER features while the copular predicate has a GENDER probe.

One common assumption about the structure of probes has been that a probe consists of multiple unvalued features. For example, the English T has both unvalued person and unvalued number. Recent work on agreement has shown that  $\varphi$ -features can probe independently. More specifically, it is quite common across languages for a verb to agree with an NP in person and agree with another NP in number. What is more, the morpheme that expones a person feature can be separate from the morpheme that expones a number feature.<sup>23</sup> Facts like these have motivated theories like *Relativized Probing* (Nevins 2011; Preminger 2014). Relativized Probing is based on the idea that a probe searches a goal with a matching feature while ignoring any other syntactic object. For example, a probe relativized for NUMBER can skip over nominals that have a PERSON or GENDER feature but not NUMBER feature.

The definition of probes in (101-a) accommodates Relativized Probing. A probe can be relativized for any  $\varphi$ -feature. Common  $\varphi$ -features are PERSON, NUMBER, and GENDER. CLASS features in some Bantu languages can also be considered as  $\varphi$ -features.<sup>24</sup> In addition to these features, I argue that there is also an underspecified  $\varphi$ -feature employed by many languages. The underspecified  $\varphi$ -feature matches any  $\varphi$ -feature. In particular, I assume the underspecified  $\varphi$ -feature to be the [+N] (nominal)feature. The common property among  $\varphi$ -features is that they can be interpretable on nouns.<sup>25</sup> In other words, a  $\varphi$ -feature presupposes a nominal feature. Hence, I assume the most underspecified  $\varphi$ -feature to be the [+N] feature.

There is one key difference between the [+N] feature and the other  $\varphi$ -features. The [+N] feature is introduced by the N(oun) (or *n*) and it is carried all the way up through the extended nominal projection. All the heads in the extended projection of a nominal carry the [+N] feature including the K head. Thus KPs are extended nominal projections as defined by Grimshaw (1991, 2005). Given that KPs are extended nominal phrases and they

---

<sup>23</sup>See Chapter 3 for examples of such languages.

<sup>24</sup>Class features are considered to be GENDER features.

<sup>25</sup>Some  $\varphi$ -features are not semantically interpretable. For example, the grammatical gender features in German are not interpretable on nouns. This is why a female noun like *Mädchen* 'girl' can get the neuter article *das*.

carry the [+N] feature, they become goals in languages where probes are underspecified, i.e. relativized for the [+N] feature. I argue that in Kurmanji, the probe on T is specified for [+N] feature. The definition of the probe and the goal in Kurmanji is given below.

(102) Kurmanji Probe

P in Kurmanji has an unvalued [+N] feature.

The definitions in (101) along with the definition of Kurmanji probe in (102) ensure the blocking effect caused by K due to Relativized Minimality (Rizzi 1990). The Kurmanji probe is looking for a goal with a [+N] feature. In a case marked nominal, K is the closest projection with a [+N] feature.<sup>26</sup> This is why agreement can only see the top layer of a nominal phrase but cannot see anything inside the KP.

Now that the grammatical objects undergoing agreement relations are defined, I provide the definitions for operations that establish agreement relations.<sup>27</sup> Agree-Link is defined as in (103).

(103) **Agree-Link** (Atlamaz and Baker 2018)

Agree-Link is an operation that establishes a relation between a probe P and the closest goal G in the local c-command domain of P by adding a pointer ( $\rightarrow$ ) from P to G.

Schematically, this can be expressed as in (104).

(104) Agree-Link (P, G) =  $P_{[\rightarrow G]}$

The term *pointer* is borrowed from the computer science literature. A pointer is an object whose value refers to another value stored elsewhere in the memory. A pointer holds the address information of the object that stores some referenced values.<sup>28</sup> Pointers can be

<sup>26</sup>I am using Bare Phrase Structure labels where a head (X) and its projection (X) have the same label. The features of a head are identical to or a subset of the features of its projection. Hence, agreement always targets the projection rather than the head. The head becomes invisible for agreement purposes due to an indistinctness relation between the head and its projection.

<sup>27</sup>I adopt the definitions we introduced in Atlamaz and Baker (2018).

<sup>28</sup>Pointers are essentially similar to Dependency Links proposed by Higginbotham (1983) and Safir (2004),

replaced by the actual values stored in the recorded address via a procedure called *dereferencing*. In the two-step agreement theory here, Agree-Link corresponds to the operation that puts a pointer with the address of the goal on a probe while Agree-Copy corresponds to the dereferencing procedure that returns the value in the address stored by the pointer (i.e. the goal). Agree-Copy is defined as follows.

(105) **Agree-Copy** (Atlamaz and Baker 2018)

Agree-Copy takes as input a substructure of the form  $P_{[\rightarrow G]}$  and returns  $P_{[\{\pi, \#, \gamma\}]}$  by replacing pointers associated with P with the  $\varphi$ -set at G.

(106)  $\text{Agree-Copy}(P_{[\rightarrow G]}) = P_{[\{\pi, \#, \gamma\}]}$

The two-step agreement mechanism described above makes it possible for a probe to agree with a goal in the syntax obeying syntactic constraints (locality, hierarchy, etc.) and then modifying the structure of the goal via operations like Fusion (also Flattening, Linearization, etc.) and finally copying values from the modified structure. This can be used to account for the Kurmanji facts discussed in Section 5.1.

In the following, I provide analyses of Kurmanji agreement facts. I start with oblique non-local nominals where number fuses with case resulting in number agreement. Consider the Kurmanji sentence (88-b) repeated below as (107).

(107) Wana nan xar-in.  
 3PL.OBL bread.DIR eat.PAST-PL  
 ‘They ate (bread/meal).’

The subject in (107) is third person plural oblique. Given that non-local pronouns lack a PARTICIPANT node, the relevant syntactic structure of (107) is as in (108). This is the output of the syntactic operation Agree-Link. In (108), Agree-Link establishes a relation between the probe on T with the K phrase which has the [+N] feature.

---

where dependencies between two syntactic objects are represented by asymmetric connections. Both Dependency Links and pointers are clear violations of the Inclusiveness Condition (Chomsky 1995).

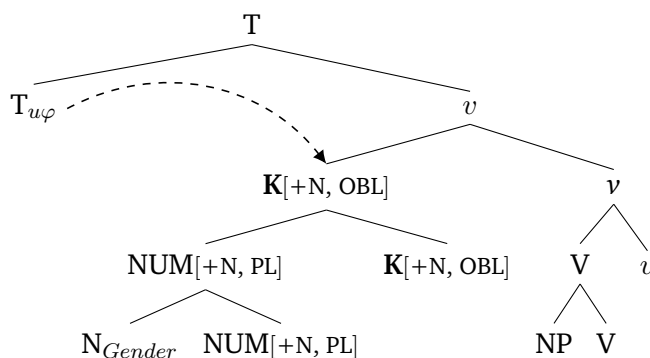
(108) *Output of Agree-Link*

The structure in (108) is fed into the morphological operation Fusion. NUM fuses with K by (96) repeated in (109) for convenience. The output of Fusion is in (110).

(109) *Kurmanji Fusion Rule for Number*

Fuse NUM with the closest c-commanding head.

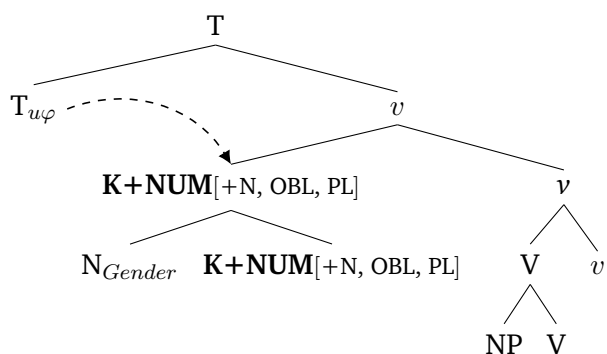
(110) *Output of Fusion*

The output of fusion is then fed into Agree-Copy which replaces the pointer on the probe (represented on (110) as the association arrow) with  $\varphi$ -values on the goal, i.e. **K+NUM** which is the maximal nominal projection. The only  $\varphi$ -value on **K+NUM** is the **PLURAL**. Thus, the output of Agree-Copy is  $T_{\{\{PL\}\}}$ . This accounts for number agreement with oblique non-local pronouns. The analysis is the same for non-pronominal nominals except that **N** is occupied by a noun rather than a pronominal index.

Number agreement with local pronouns is not possible in Kurmanji due to fusion patterns. Consider the following example.

- (111) M-e hew di / \*di-n.  
**1PL-OBL 3SG.DIR saw / saw-PL**  
 ‘We saw her/him/it.’

In this case, the oblique subject is a local pronoun with a PARTICIPANT node in the structure. The relevant syntactic structure of (111) is as in (112).

- (112) *Output of Agree-Link*

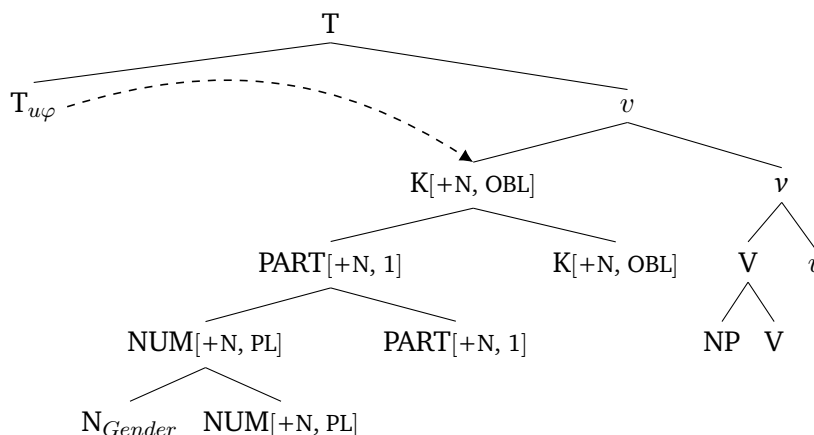

When the structure in (112) is fed into Fusion, NUM cannot fuse with K due to the intervening PART head. Instead, NUM fuses with PART to the exclusion of K as in (113). As a result, K does not host any  $\varphi$ -features.

- (113) *Output of Fusion*

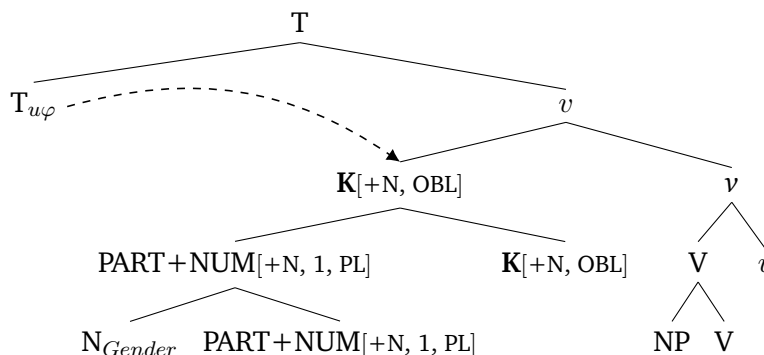

In this configuration, when Agree-Copy happens it returns a probe with an empty set of  $\varphi$ -values ( $T_{\{\}} \}$ ). As a result, we get no (surface) agreement with an oblique local pronoun.

Finally, let me discuss a case of full number and person agreement when the subject is a direct nominal as in (114).

- (114) **Ez** rvi-m.  
**1SG.DIR ran-1SG**  
 'I ran.'

The structure of (114) is quite similar to the structure of (111) with the only relevant difference being the lack of a K head on the subject. Since direct nominals lack a K head, T agrees with PART, the highest nominal projection, as in (115).

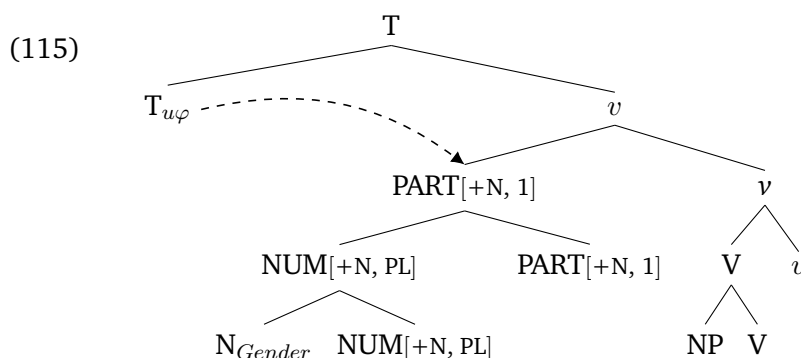

Like in the oblique local pronouns, when the structure in (115) is fed into Fusion, NUM fuses with PART as in (116). Since there is no K, PART+NUM is the closest maximal nominal projection. This enables the transfer of both NUMBER and PERSON features when Agree-Copy applies. Agree-Copy returns  $\mathbf{T}_{\{1, PL\}}$ , yielding full PERSON and NUMBER agreement with the subject.

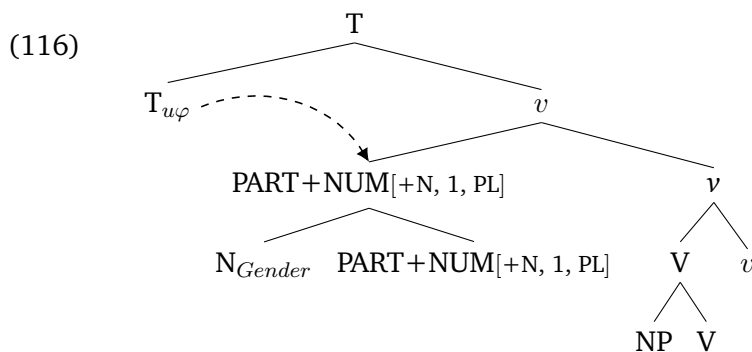

So far, I have accounted for three types of agreement patterns: NUMBER AGREEMENT with



non-local oblique nominals, NO AGREEMENT with oblique local pronouns, and FULL AGREEMENT with direct local pronouns. All the other agreement facts can be accounted for by the theory presented in this section. The table in (117) summarizes all the patterns and shows how they are accounted for.

(117)

	PRE-FUSION	AGREE-LINK	POST-FUSION	AGREE-COPY
a.	[[NUM] PART]	$T_{[\rightarrow PART]}$	[NUM + PART]	$T_{\{\{ PART, NUM \}\}}$
b.	[[[NUM] PART] K]	$T_{[\rightarrow K]}$	[[NUM + PART] K]	$T_{\{\{ \}\}}$
c.	[NUM]	$T_{[\rightarrow NUM]}$	[NUM]	$T_{\{\{ NUM \}\}}$
d.	[[NUM] K]	$T_{[\rightarrow K]}$	[NUM + K]	$T_{\{\{ NUM \}\}}$

To sum up, in this section, I have argued that surface agreement is a result of two operations, Agree-Link and Agree-Copy. Agree-Copy applies at PF, specifically after the post-syntactic operation Fusion. In languages like Kurmanji, probes are “coarse”. They are specified for a [+N] feature. When Agree-Link applies in the syntax, it finds the closest projection with a [+N] feature. Assuming that KPs are extended nominal projections (along with all the other nominal projections), when a nominal is case marked, Agree-Link establishes a relation with the K node by registering its address information via a pointer.<sup>29</sup> Post-syntactic operations like Fusion can change the structures of goals. When Agree-Copy happens, it is sensitive to the output of Fusion. This accounts for the full agreement with direct nominals as well as the partial agreement with oblique nominals in Kurmanji. The analysis provided here is also in line with Hypothesis I repeated below.

(118) **Hypothesis I** – Different Goals

Cross-linguistic variation in agreement is due to the differences in the structures of goals.

Hypothesis I is stated as a generalization for cross-linguistic variation. I have shown that it can account for variation within a language. In the next section, I show that it can account for cross-linguistic variation in Case-Sensitive languages as well.

<sup>29</sup>Assuming bare phrase structure, it is not important whether the goal is the K head or the K phrase.

## 6 Extension to Other Languages

In the previous sections, I have shown that Hypothesis I holds. Whether a nominal can be agreed with or not has a lot to do with its structure. In languages like Kurmanji where agreement probes look for a [+N] feature, the topmost layer of a nominal will always intervene preventing any direct agreement with what is inside the nominal. When a nominal does not have case, the probe can see the nominal and agree with it. On the other hand, when a nominal is encapsulated inside a K phrase, the K phrase will always block agreement unless some  $\varphi$ -feature fuses with K to become visible to the Agree-Copy operation.

The predictions of the theory are clear. In languages where nothing fuses with K, there should be no agreement at all. On the other hand, in languages where a  $\varphi$ -feature fuses with K, that  $\varphi$ -feature should be agreed with. In this section, I discuss facts from Hindi, Faroese, and Icelandic to test the predictions of the theory.<sup>30</sup> Hindi is a language where nothing fuses with case while Faroese and Icelandic are languages where NUMBER fuses with K, like in Kurmanji.

### 6.1 Accounting for Hindi – a *totally sensitive* language

Like Kurmanji, Hindi is a split-ergative language. In Hindi, agreement tracks the morphologically unmarked nominal. Among Case-Sensitive languages, Hindi is totally sensitive, where agreement with an overtly case marked nominal is never possible.

- (119) a. Siita baazaar gayii.  
Sita.FEM market go.PAST.FEM.SG  
'Sita went to the market.'
- b. Raam-ne roṭii khyaayii thii.  
Raam.MASC-ERG bread.FEM eat.PERF.FEM be.PAST.FEM  
'Ram had eaten bread.' (Mahajan 1990a, p. 73)
- c. Siita-ne larkii-ko dekhaa.  
Sita.FEM-ERG girl.FEM-ACC see.PERF.MASC  
'Sita saw the girl.' (Bobaljik 2008)

In (119-a), the subject is morphologically unmarked and the verb agrees with it in gender.

<sup>30</sup>The analysis of these languages was developed in Atlamaz and Baker (2018) along with my dissertation.

In (119-b), the subject is ergative while the object is morphologically unmarked and the verb agrees with the object in gender. Finally in (119-c), both the subject and the object are overtly case marked and the verb does not agree with either. Instead, the verb shows default masculine agreement, even though both the subject and the object are feminine.

A closer look at the structure of nominals in Hindi reveals that case never fuses with any features in Hindi. Ergative case is always exponed by the *-ne* suffix while accusative is always exponed by the *-ko* suffix. This is clearly seen in (120).

(120) *Hindi pronoun declension* (Atlamaz and Baker 2018)

PERSON	UNMARKED		ERGATIVE		ACCUSATIVE	
	SG	PL	SG	PL	SG	PL
1	maĩ	ham	maĩ-ne	ham-ne	mujh-ko	ham-ko
2 <sub>familiar</sub>	tum	tum-log/sab	tum-ne	tum-logõ-ne	tum-ko	tum-logõ-ko
2 <sub>respectful</sub>	aap	aap-log	aap-ne	aap-logõ-ne	aap-ko	aap-logõ-ko
2 <sub>intimate</sub>	tu	tu-log	tu-ne	tu-logõ-ne	tujh-ko	tum-logõ-ko
3 <sub>familiar-prox</sub>	yah	ye-log	is-ne	inhõ-ne	is-ko	in-ko
3 <sub>familiar-dist</sub>	wo	ve-log	us-ne	unhõ-ne	us-ko	un-ko

Given that nothing fuses with K, the prediction is that we get no agreement with overtly case marked nominals. The relevant structure of a Hindi clause with an overtly case marked nominal would be as in (121).

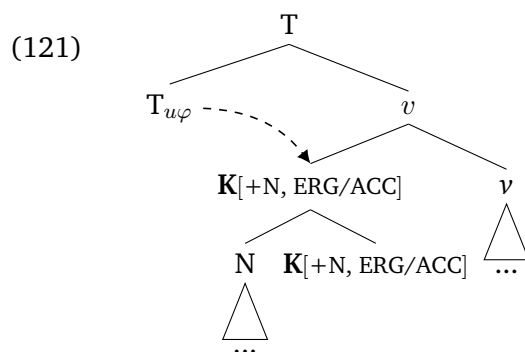

In (121), Agree-Copy registers the address information of the overtly case marked nominal as the probe is looking for a [+N] feature. Fusion does not change the structure in any way. Hence, when Agree-Copy applies, it returns an empty set as there are not  $\varphi$ -features hosted by K. By this token, we never get agreement with overtly case marked nominals in Hindi. Other CASE-SENSITIVE languages like Tsez, Tamil are similar to Hindi. In these

languages, case never fuses with any  $\varphi$ -feature and we don't get any agreement with case marked nominals.

## 6.2 Accounting for Faroese and Icelandic

Faroese and Icelandic are languages where number fuses with case like in Kurmanji. The table in (122) illustrates a small portion of the Faroese case paradigm while the one in (123) illustrates Icelandic.

(122) Fusion in Faroese (*fund* “meeting”)

- a. fund-ur    NOM, SG
- b. fund-ir    NOM, PL
- c. fund-i     DAT, SG
- d. fund-um    DAT, PL

(Lockwood 1955, p. 30)

(123) Fusion in Icelandic (*hest* “horse”)

- a. hest-ur    NOM, SG
- b. hest-ar    NOM, PL
- c. hest-i     DAT, SG
- d. hest-um    DAT, PL

(Thráinsson 1994, p. 153)

In both Faroese and Icelandic, case and number are exponed on the same morpheme. For example, DAT.PL is realized as *-um* in both languages. Given these facts, the theory presented in this chapter predicts that plural datives can be agreed with in number in both Faroese and Icelandic. The prediction is borne out in Faroese. In Faroese, dative subjects can be agreed with in number as illustrated in (124).

(124) a. **Liðunum**            mangla venjara.  
 team.PL.THE.DAT lack.3PL trainer.acc  
 ‘The teams need (lack) [a] trainer.’

- b. **Børnunum**        tørva    eina góða    fyrimynd.  
 child.PL.THE.DAT need.3PL a.ACC good.ACC role.model.ACC  
 ‘The children need a good role model.’

Faroese (Jónsson 2009, p. 156)

Icelandic, on the other hand, is famous for its dative subjects not being agreed with. Although number fuses with case in Icelandic too, plural agreement with dative subjects is impossible.

- (125) a. Ferðunum seinkaði.  
 journey.PL.THE.DAT **was**.delayed  
 ‘The journeys (were) delayed.’ Icelandic (Sigurðsson 2004, p. 138)
- b. Þeim líð-ur vel.  
 them.DAT **feels** good  
 ‘They feel fine.’ (3PL would be líð-a) (Thráinsson 2007, p. 159)

The Icelandic facts contrast with Kurmanji and Faroese in which number agreement is possible in cases when number fuses with case. This is summarized in (126).

	Kurmanji	Faroese	Icelandic
(126) Fusion (NUM +K)	YES	YES	YES
Partial Agreement	YES	YES	NO

Why do we get partial agreement in Kurmanji and Faroese but no agreement in Icelandic? The theory predicts that in Icelandic too, number agreement with dative subjects where number fuses with dative should be possible. Following Atlamaz and Baker (2018), I argue that this is in fact the case but the difference lays in the verbal morphology. In Section 4.2, I showed that Kurmanji has an underspecified plural morpheme that can be inserted in all of the plural contexts (1PL, 2PL, 3PL). The disjunctive rule block for Agreement is given in (127).

- (127) *Kurmanji disjunctive rule block for agreement*
- Agr  $\longleftrightarrow$  *-m* / 1SG
- Agr  $\longleftrightarrow$  *-i* / 2SG
- Agr  $\longleftrightarrow$  *-ni* / 1PL (optional) (Atlamaz and Baker 2018)
- Agr  $\longleftrightarrow$  *-n* / PL
- Agr  $\longleftrightarrow$  *-e / Ø* / ELSEWHERE

Similarly, in Faroese too, there is an underspecified vocabulary item for plural. There are no person distinctions in the plural (Jónsson 2009; Lockwood 1955).

(128) Inflection of *dáma* ‘like’ in present tense

dámi	1SG	dáma	1PL
dámar	2SG	dáma	2PL
dámar	3SG	dáma	3PL

Faroese

(129) Vocabulary Items

Agr  $\longleftrightarrow$  *-a* / PL

Agr  $\longleftrightarrow$  *-i* / 1SG

Agr  $\longleftrightarrow$  *-ar* / ELSEWHERE

(Atlamaz and Baker 2018)

In Kurmanji and Faroese, when Agree-Copy copies only the [PLURAL] value from a case marked nominal, there are underspecified plural morphemes that can realize this agreement. In Icelandic, however, all the vocabulary items that refer to [PLURAL] also refer to a person feature as well. The vocabulary items are fully specified. (130) shows the paradigm for the present indicative; the same is true for the indicative past and the subjunctives (Thráinsson 2007, p. 8).

(130) Present Indicative

- |    |              |                 |
|----|--------------|-----------------|
| a. | Ég bít.      | ‘I bite.’       |
| b. | Ðú bít-ur.   | ‘You bite.’     |
| c. | Hann bít-ur. | ‘He bites.’     |
| d. | Við bít-um.  | ‘We bite.’      |
| e. | Þið bít-ið.  | ‘You all bite.’ |
| f. | Þeir bít-a.  | ‘They bite.’    |

Icelandic

The vocabulary insertion rules for the present indicative in Icelandic are as in (131):

(131) *Agreement morphology for present indicative in Icelandic*

Agr  $\longleftrightarrow$  *-um* / 1PL

Agr  $\longleftrightarrow$   $-\emptyset$  / 1SG

Agr  $\longleftrightarrow$  *-ið* / 2PL

Agr  $\longleftrightarrow$  *-a* / 3PL

Agr  $\longleftrightarrow$  *-ur* / ELSEWHERE

(Atlamaz and Baker 2018)

In Icelandic, when Agree-Copy copies only the [PLURAL] value from a dative subject, this cannot be realized on the verb as a result of the Subset Principle ((132)), which bans the insertion of a vocabulary item that is more specific than what the insertion node specifies.

(132) *Subset Principle*

(Halle and Marantz 1993, p. 276)

In order for a vocabulary item to be inserted at a terminal node, the identifying features of the vocabulary item must be a subset of the features at the terminal node.

The realization of plural agreement with dative subjects in Icelandic is then prevented by the Subset Principle. Instead of plural agreement, default *-ur* is exponed in such cases.<sup>31</sup>

To sum up this section, I have argued that the cross-linguistic variation observed in agreement in CASE-SENSITIVE languages is due to the structural properties of nominals in these languages. In *totally sensitive* languages like Hindi, K never fuses with any phi features and blocks any agreement with a case marked nominal. In *partially sensitive* languages like Kurmanji, fusion of a  $\varphi$ -feature with K makes that  $\varphi$ -feature visible for agreement purposes. I have also argued that Icelandic, which looks like a *totally sensitive* language, is actually a *partially sensitive* language where number agreement with a plural dative subject goes through but cannot be realized due to the details of verbal morphology. This generates some *unrealized agreement* which is hard to detect. I argue that this is a desired outcome for Icelandic.

In Icelandic, there is some evidence that indicates that dative subjects are agreed with. In transitive expletive constructions where the thematic subject is a dative, verbs can be

<sup>31</sup>The analysis of Faroese and Icelandic presented in this section was developed in Atlamaz and Baker (2018).

plural only when both the subject and the object are plural as in (133) but not when one of them is singular and the other is plural as in (134) and (135).<sup>32</sup>

- (133) Það finnast mörgum stúdentum tölvurnar ljótar.  
EXPL seem.PL many student.PL.DAT computer.THE.PL.NOM ugly  
'Many students find the computers ugly.'
- (134) \*Það finnast einhverjum stúdent tölvurnar ljótar.  
EXPL seem.PL some student.SG.DAT computer.THE.PL.NOM ugly  
'Some student finds the computers ugly.'
- (135) \*Það finnast mörgum stúdentum tölvan ljót.  
EXPL seem.PL many student.PL.DAT computer.THE.SG.NOM ugly  
'Many students find the computer ugly.' (Holmberg and Hróarsdóttir 2003, p. 1006)

I take the facts in (133)-(135) to be an indication of (Multiple) agreement with dative subjects in Icelandic. In the next section, I discuss object agreement in Kurmanji.

## 7 Agreement with Objects in Kurmanji

In Section 5, I developed a theory of agreement that accounts for the partial agreement with oblique subjects in Kurmanji and in Section 6, I extended the analysis to Hindi, Icelandic and Faroese to capture a typology of languages where agreement is sensitive to case marking on goal NPs. In this section, I go back to agreement with objects in Kurmanji.<sup>33</sup> In Kurmanji past tense clauses, direct objects, which are morphologically unmarked (traditionally called direct), can (and must) be agreed with in person and number.

- (136) Mehemed-ê ez di-m.  
Mehemed-OBL 1SG.DIR see.PAST-1SG  
'Mehemed saw me.'

<sup>32</sup>It should be noted that Holmberg and Hróarsdóttir (2003) report (133) to be marginally acceptable.

<sup>33</sup>The analysis of Kurmanji object agreement was developed in Atlamaz and Baker (2016) and Atlamaz and Baker (2018) along with my dissertation.



Full person and number agreement with an object prevents number agreement with subjects. While plural agreement with an oblique subject is possible when the object is third person, this is not possible when the object is first or second person.

- (137) **Wana** hew di-**n**.  
 3PL.OBL 3SG.DIR see.PAST-PL  
 ‘They saw him.’
- (138) **Wana** ez di-**m** / \*-n / \*-ni.  
 3PL.OBL 1SG.DIR see.PAST-1SG / PL / 1PL  
 ‘They saw me.’
- (139) **Wana** tı di-**yi** / \*-n.  
 3PL.OBL 2SG.DIR see.PAST-2SG / PL  
 ‘They saw you.’

In Section 5, I proposed that the agreement probe in Kurmanji is relativized for the [+N] feature. Also, I have shown that oblique subjects are active for agreement purposes. Given that the probe is on T in Kurmanji, we would expect subjects to block agreement with objects, not the other way around.

Another curious fact regarding object agreement in Kurmanji is its absence in present tense clauses. Object agreement is never possible in present tense clauses. Consider the past tense clause in (137). The object is third person direct while the subject is third person plural. When the object is third person, plural subjects can be agreed with in number.<sup>34</sup> Although the privilege of agreement seems to be with the object in clauses like (138) and (139), in which the object is a local direct pronoun, the privilege moves to the subject when the object is third person as in (137). If this is just a matter of intervention, we might expect to get plural agreement with the object in a present tense clause like in (140). Yet, plural agreement with an oblique object is sharply out.

- (140) Hew wana dı-wun-ê / \*dı-wun-in-ê.  
 3SG.DIR 3PL.OBL IMPF-see-3SG.COP / IMPF-see-PL-COP  
 ‘S/he sees them.’

<sup>34</sup>This is only observable in cases when the object is singular. When both the object and the subject are plural, it is impossible to say which argument the verb agrees with.

Why is object agreement privileged over subject agreement in past tense clauses and why is object agreement completely impossible in present tense clauses? I propose that the answers come from Multiple Agree (Hiraiwa 2005) and the Phase Impenetrability Condition (PIC) (Chomsky 2000, 2001), respectively.

In Kurmanji, the agreement probe is on T. Agreement with a direct object across an oblique subject is possible because Kurmanji employs Multiple Agree. This is why intervention is not a problem. Multiple vs. Single Agree is a matter of parametric variation and languages differ in terms of which one they employ. In the two-step agreement model I proposed earlier, Multiple Agree requires a new definition of Agree-Link, which I provide in (141-a).<sup>35</sup>

(141) *Multiple Agree* (Atlamaz and Baker 2018)

- a. **Agree-Link**<sub>Multiple</sub> establishes a relation between a probe P and all goals G within the local c-command domain of P by adding pointers ( $\rightarrow$ ) from P to each of the Gs.

Schematically, given a probe P and goals  $\{G_1, \dots, G_n\}$ , Multiple Agree returns: P  $\left[ \begin{array}{l} \rightarrow G_1 \\ \rightarrow G_2 \\ \rightarrow G_n \end{array} \right]$

Multiple Agree establishes agreement relations with all the NPs within the local c-command domain of an agreement probe. Agree Copy transfers all the available  $\varphi$ -features to the probe and creates complex feature bundles. The derivation of a clause like (138) where the subject is an oblique third plural and the object is direct first singular is given in (142).

---

<sup>35</sup>The definition of Multiple Agree is adopted from Atlamaz and Baker (2018).

(142) *Output of Agree-Link (Multiple Agree)*

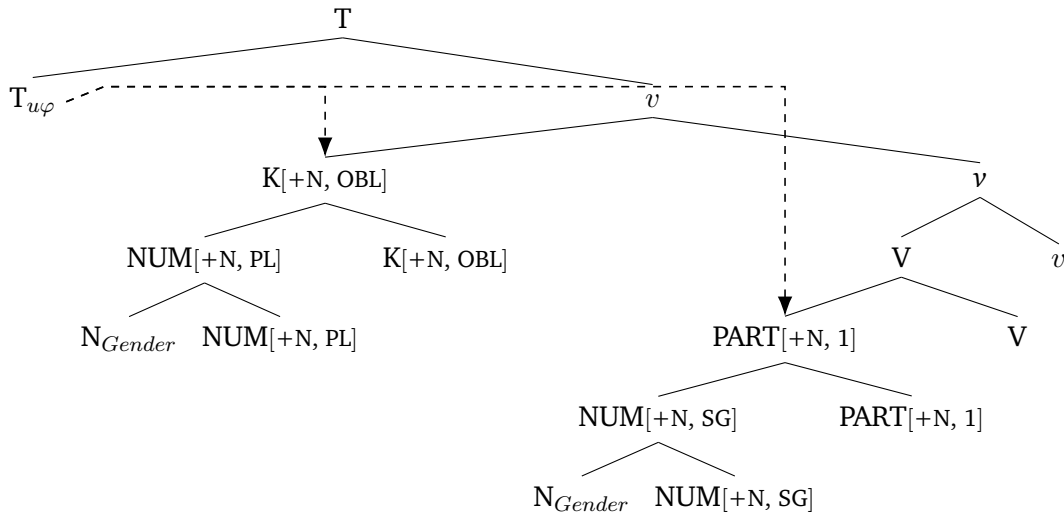

Once Agree-Link applies, the structure in (142) is further fed into Fusion, which returns (143).

(143) *Output of Fusion*

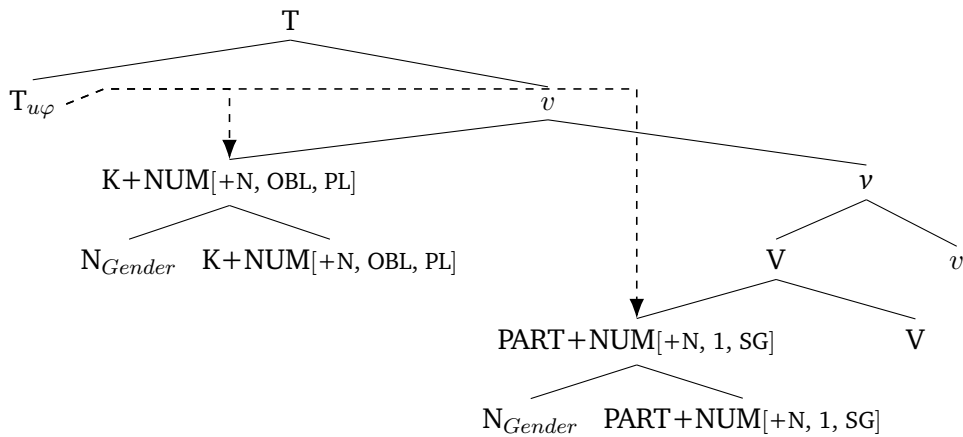

When Agree-Copy applies to the structure in (143), it returns the complex feature bundle that consists of different  $\varphi$ -sets as in (144).

(144) 
$$T \begin{bmatrix} \{PL\} \\ \{1, SG\} \end{bmatrix}$$

The complex feature bundles created by Multiple Agree cause problems for vocabulary insertion. How does the grammar decide which features to realize and which vocabulary items to use? Although in the general case this is a complex matter that requires further investigation, I propose a solution for Kurmanji. Following van Koppen (2007), I assume that the realization of complex feature bundles depends on the vocabulary items in a given language and the Elsewhere Principle.

- (145) *Elsewhere Principle* (Anderson 1992, p. 132)  
Application of a more specific rule blocks that of a later more general rule.

When the complex feature bundle in (144) is further fed into Vocabulary Insertion, the Elsewhere Principle applies based on the vocabulary items in Kurmanji given in (127) repeated below for convenience.

- (146) *Kurmanji disjunctive rule block for agreement*
- |     |   |        |   |                |                          |
|-----|---|--------|---|----------------|--------------------------|
| Agr | ↔ | -m     | / | 1SG            |                          |
| Agr | ↔ | -i     | / | 2SG            |                          |
| Agr | ↔ | -ni    | / | 1PL (optional) | (Atlamaz and Baker 2018) |
| Agr | ↔ | -n     | / | PL             |                          |
| Agr | ↔ | -e / ∅ | / | ELSEWHERE      |                          |

The two vocabulary items that are in competition for the complex feature bundle in (144) are *-n* and *-m*. In this competition, *-m* wins because it is more specific than *-n* as it refers to both number and person features.<sup>36</sup> The same reasoning applies to all the other cases when the object is first or second person. In past tense clauses, oblique subjects can only contribute plural features, maximum. This is why first and second person objects are always privileged on the surface while there is agreement with both the subject and the object. The proposal also accounts for cases when the object is third person. When the object is third singular and the subject is third plural, *-n* wins over *-e/∅* because *-n* is specified for plural while *-e/∅* is not specified as it is the elsewhere form.

<sup>36</sup>Also, first person is considered to be universally more specific and ranks higher than plural according to Noyer (1997).

To sum up, agreement with objects in past tense clauses is due to Multiple Agree which copies features from both arguments and creates complex feature bundles. First and second person objects seem privileged for agreement. However, this is just a matter of Vocabulary Insertion which resolves a complex feature bundle by inserting the most specific vocabulary item in accordance with the Elsewhere Principle.

Next, let me briefly comment on the impossibility of agreement with oblique objects in present tense clauses.

- (147) Hew wana d1-wun-ê / \*d1-wun-in-ê.  
 3SG.DIR 3PL.OBL IMPF-see-3SG.COP / IMPF-see-PL-COP  
 ‘S/he saw them.’

Given the possibility of Multiple Agree, we might expect to get plural agreement in a present tense clause like (147). Why don’t we?

The answer is quite straightforward given my assumptions regarding the structure of present tense and past tense clauses in Kurmanji. In Section 4.3, I argued that the key difference between the two types of clauses is the status of *v* as a phase head. In present tense clauses, *v* is a phase head dividing the clause into two case domains yielding accusative alignment, whereas in past tense clauses *v* is not a phase head resulting in dependent case assignment which is responsible for the ergative alignment. This proposal also accounts for the lack of agreement with objects in present tense clauses. Since *v* is a phase head in present tense clauses, the object is spelled-out by the time the probe is introduced into the structure. Hence, the probe cannot see the object at all due to the Phase Impenetrability Condition. Thus, we never get agreement with objects in Kurmanji present tense clauses. This phase-based explanation accounts for both the split ergativity and the complex agreement facts in Kurmanji straightforwardly.

I have now completed the discussion of Kurmanji case and agreement facts and provided a theory of agreement that can capture a variety of languages in which agreement is sensitive to case patterns. In the next chapter, I return my attention to languages where agreement is not sensitive to case marking to capture a larger typology of languages.

## 3

## CASE-INSENSITIVE LANGUAGES

The previous chapter focused on CASE-SENSITIVE languages, in which overt case marking on a nominal disturbs agreement partially or fully. I have argued that the variation in agreement with a case marked nominal arises as a result of the structural details of the goal of the Agree process. I have shown that in Kurmanji, the degree of disruption correlates with the presence or absence of overt case on a nominal and whether any  $\varphi$ -node fuses with case or not. This confirms Hypothesis I, repeated below in (1) and captures a set of languages mentioned by the overall typology of case and agreement relations in (2).

(1) **Hypothesis I – Different Goals**

Some cross-linguistic variation in agreement is due to the differences in the structures of goals.

(2)

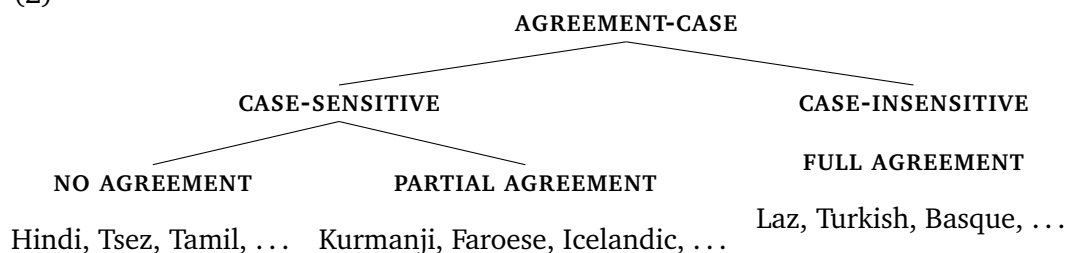

Hypothesis I accounts for variation among CASE-SENSITIVE languages but fails to generalize

to CASE-INSENSITIVE languages where agreement is not disrupted by overt case at all. In these languages, agreement goes through in full despite overt case on a given nominal. For example in Laz, ergative is exponed by the invariant *-k* suffix on third pronouns and common nouns. It does not fuse with any  $\varphi$ -features, yet agreement with an ergative nominal is still possible.

- (3) Bere-pe-k ma m-dzir-es.  
 child-PL-ERG 1SG.NOM 1-see-3PL  
 ‘The children saw me.’ (Demirok 2013, p. 183)

Similarly, in Nepali, ergative case is exponed by the invariant *-le* and the verb can still agree with the subject in number and person.

- (4) mai-le yas pasal-mā patrikā kin-ē.  
 1SG-ERG DEM.OBL store-LOC newspaper.NOM buy.PAST-1SG  
 ‘I bought the newspaper in this store.’ Nepali (Bobaljik 2008, p. 310)

Hypothesis I predicts that, in Laz and Nepali, overtly case marked nominals should not be agreed with at all. Why does case not prevent agreement in these languages? For this, it is helpful to remember why case blocks agreement at all in CASE-SENSITIVE languages. I have argued that in CASE-SENSITIVE languages, the agreement probe is searching for a general [+N] feature. Any phrase with a [+N] feature can be a goal. Thus, when K projects a KP phrase above the nominal, it becomes the closest phrase with a [+N] feature and intervenes in any relations between a probe and any feature further down inside the KP. In contrast, if the  $\varphi$ -probe is specified for a more specific feature, it should ignore irrelevant syntactic objects and be able to establish a relation with the particular feature it is looking for (within the same phase). This idea is called by Nevins (2011) and Preminger (2014) *Relativized Probing*. Relativized Probing builds on the commonly held view that PERSON, NUMBER and GENDER probes may be distinguished and introduced separately (Béjar and Rezac 2009; Laka 1993; Preminger 2014; Shlonsky 1989; Sigurðsson and Holmberg 2008). Each probe then can skip over all the other syntactic objects with irrelevant features and agree with the relevant feature, as long as global locality conditions allow it.

I argue that the difference between CASE-SENSITIVE languages like Hindi, Kurmanji, and Faroese and CASE-INSENSITIVE languages is due to differences in the nature of probes in these languages. In CASE-SENSITIVE languages, agreement probes are specified for [+N] while in CASE-INSENSITIVE languages, they are specified for specific features like NUMBER, PERSON, AND GENDER. This means that Hypothesis II also holds, but at a different level of the overall typology.

(5) **Hypothesis II – Different Probes**

Some cross-linguistic variation in agreement is due to differences in the structures of probes.

The idea that cross-linguistic variation should follow from the independent lexical properties of functional heads in different languages has a lot of precedents. Baker (2008) names this the Borer-Chomsky Conjecture (Borer 1984; Chomsky 1995). The two hypotheses that I entertain here go beyond the Borer-Chomsky conjecture by also considering the variation caused by the structural configurations of functional heads. The variation in terms of CASE-SENSITIVITY, i.e. whether agreement in a language is sensitive to case marking or not, is due to the differences in agreement probes in these languages. The level of specification on agreement probes determines whether a language is sensitive to case marking or not. In contrast, the variation within CASE-SENSITIVE languages in terms of the degree of disruption in agreement (no agreement vs. partial agreement) is due to the structure of the goals. This is illustrated by (6).

(6)

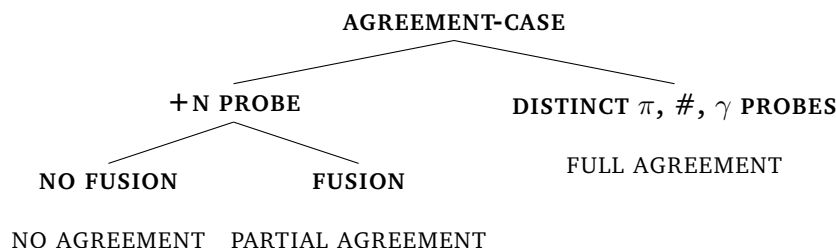

In the following, I present some independent evidence from Laz and Turkish supporting



Hypothesis II.

## 1 Laz

Laz (ISO 639-3 [lzz]) is an endangered South-Caucasian language spoken in the eastern Black Sea region in Turkey. The data below comes from the Pazar dialect of Laz spoken in the Pazar district of Rize, Turkey. The name of the language in Laz is Lazuri and it is also known as Atinan. The data for this study comes from Öztürk and Pöchtrager (2011), Demirok (2013), and my own fieldwork.<sup>1</sup>

Laz is an ergative language with complex case and agreement facts. Let me start with case marking in Laz. Noun phrases are overtly marked for ergative and dative cases.

(7)	NOUN	UNMARKED		ERGATIVE		DATIVE	
		SG	PL	SG	PL	SG	PL
	child	bere	bere-pe	bere-k	bere-pe-k	bere-s	bere-pe-s

Participant pronouns appear in the same form across all cases while third person pronouns behave just like common nouns except that plural seems to fuse with the person in pronouns while in common nouns plural is expressed with the invariant suffix *-pe*.

(8)	PERSON	UNMARKED		ERGATIVE		DATIVE	
		SG	PL	SG	PL	SG	PL
	1	ma	şk'u	ma	şk'u	ma	şk'u
	2	si	t'k'va	si	t'k'va	si	t'k'va
	3	him(u)	hini	himu-k	hini-k	himu-s	hini-s

Although participant pronouns seem not to have any case marking on them, there is some evidence that indicates that ergative participant pronouns are KPs. Demirok (2013) shows that multi-word DPs containing a participant pronoun show overt case as in (9).

<sup>1</sup> A large portion of the work on Laz has been possible thanks to diligent efforts of our consultant İsmail Avcı Bucak'lışı. He has been the main consultant for the work done by Demirok (2013), Erguvanlı Taylan and Öztürk (2014), Öztürk (2013), Öztürk and Erguvanlı Taylan (2017), and Öztürk and Pöchtrager (2011) among others. His contributions to the literature on Laz and the Laz community cannot be overstated.

- (9) T'k'va iri-**k** şk'u m-dzir-i-t.  
 2SG.ERG all-ERG 1PL.NOM 1-see-PAST. $\pi$ -PL  
 'You all saw us.' (Demirok 2013, p. 7)

Despite being KPs, person and number agreement is still possible with ergative nominals.

- (10) Bere-**pe-k** ma m-dzir-**es**.  
 child-PL-ERG 1SG.NOM 1-see-PAST.3.PL  
 'The children saw me.' (Demirok 2013, p. 183)

Unlike in Kurmanji, case and number do not fuse in Laz. In (10), the subject is *bere-pe-k* which consists of the root *bere* "child", the invariant plural morpheme *-pe*, and the invariant ergative morpheme *-k*. There is no fusion and yet the verb agrees with the subject in number and in person. Subject agreement is encoded with suffixes on the verb and we observe 3PL agreement on the verb in (10).

When the ergative subject is a third plural pronoun, there is some indication of number and person fusion but there is still no fusion with case as case is still the invariant *-k* suffix.

- (11) **Hini-k** ma m-dzir-**es**.  
 3PL-ERG 1SG.NOM 1-see-PAST.3.PL  
 'They saw me.'

Finally, when the subject is first or second ergative pronoun, there is full person and number agreement with the ergative subject. One such example was in (9) where the subject is second plural ergative and the verb shows person (glossed as  $\pi$ ) and number agreement with the ergative subject. Clearly, the lack of fusion in Laz does not bleed agreement as it does in Hindi and in parts of the Kurmanji paradigm. This needs to be accounted for. However, let me first go through some questions regarding the nature of first and second pronouns in Laz.

As shown in (8), first and second pronouns do not change depending on the case paradigm they appear in. For example, 1SG is *ma* in nominative, ergative, and dative paradigms. The same is true for all the other local pronouns. In (9), I have shown that ergative pronouns have a K node that appears when a quantifier like *iri* "all" modifies the

pronoun. But what happens to K when there is no modifier? Does it fuse with the pronoun or is it just a silent head with a  $\emptyset$  morpheme? Given that the shape of the pronoun never changes, I assume that K does not fuse with number or person. Rather, it is a  $\emptyset$  morpheme inserted along the lines of the following vocabulary insertion rules in (12).

- (12) *Ergative in Laz*
- |           |                       |              |               |
|-----------|-----------------------|--------------|---------------|
| $K_{ERG}$ | $\longleftrightarrow$ | $-\emptyset$ | / PARTICIPANT |
| $K_{ERG}$ | $\longleftrightarrow$ | $-k$         | / ELSEWHERE   |

Whether K fuses with any of the  $\varphi$ -features or not is not significant in Laz as agreement does not care whether a given NP is case marked or not. However, it does matter when we compare Laz with Tsez, another Caucasian language. In Tsez too, only common nouns and third nominals are marked for ergative case while first and second pronouns remain the same across different case paradigms.

- (13)
- | PRONOUN | ABS | ERG |
|---------|-----|-----|
| 1SG     | bi  | bi  |
| 2SG     | mi  | mi  |
- (Comrie, Polinsky, and Rajabov 1998)

What is different in Tsez is that agreement with ergative subjects is impossible even when the subject is first or second person, which has the same surface form as absolutive first or second pronoun. This indicates that agreement is not sensitive to overt realization of case. Instead, it is sensitive to the presence/absence of a K head and whether anything fuses with it. Obviously, this raises a learnability challenge. If first and second person pronouns have the same surface forms across different case paradigms, how does the learner distinguish between the structures of an absolutive and an ergative pronoun with isomorphic surface forms? I take it that learning is paradigmatic. All the nominals that appear in the ergative context are treated as ergative with a K head while all the nominative/absolutive nominals are treated as caseless despite the lack of evidence in their surface forms. Once the learner figures out that third person pronouns and common nouns get ergative case in certain configurations, this is generalized to the entire paradigm regardless of the surface shape of the pronoun forms. This is why overtly case marked nominals (common nouns

and third pronouns) and bare nominals (first/second) are treated the same in terms of agreement in Tsez. The same applies for Laz, too.

Given that in Laz case does not fuse with any of the  $\varphi$ -features, why do we get full person and number agreement in Laz? What makes Laz different from Kurmanji and also Tsez? I propose that the answer is in the details of the verbal morphology. Unlike in Kurmanji and Tsez, the verbal agreement morphology in Laz is highly specified and rich. The verbal complex in Laz has three different slots for cross-referencing the NPs. The prefix position can cross-reference NPs with different grammatical functions and looks like it cross-references person features of an NP. On the other hand, the two suffix positions cross-reference PARTICIPANT and NUMBER features independently.

- (14) Ma t'k'va g-dzir-i-t.  
 1SG.ERG 2PL.NOM 2-see-PAST. $\pi$ -PL  
 'I saw you (pl).' (Demirok 2013)

In (14), the participant suffix (glossed as  $\pi$ ) cross-references the subject while the number suffix cross-references the plural object. Number is omnivorous in Laz. When the subject or the object is plural, the verb shows plural agreement.<sup>2</sup> In (15), the subject is plural while the object is singular. This time, the number suffix cross-references the plural subject.

- (15) T'k'va ma m-dzir-i-t.  
 2PL.ERG 1SG.NOM 1-SEE-PAST. $\pi$ -PL  
 'You (pl) saw me.'

The person suffix, on the other hand, always cross-references the subject. I gloss the person suffix as  $\pi$  for participant pronouns or as 3 for non-participant nominals. The Laz person suffix does not distinguish first and second pronouns. They are both exponed as *-i*, which is a fusion of [PAST] and [+PARTICIPANT] as opposed to *-u* which expones [PAST] and [-PARTICIPANT].<sup>3</sup> The same syncretism happens in other tenses too. In non-past tenses [+PARTICIPANT] is  $\emptyset$  marked on the verb while [-PARTICIPANT] triggers *-s*. The table below

<sup>2</sup>There are some restrictions I come back to.

<sup>3</sup>I leave open whether the person suffix copies first and second person features but it is realized by an underspecified vocabulary item or just a [+PARTICIPANT] feature.

illustrates the person suffixes in Laz.

(16)	<b>PERSON</b>	<b>PAST</b>	<b>NON-PAST</b>	
	1	-i	∅	(Demirok 2013, p. 75)
	2	-i	∅	
	3	-u	-s	

If the person suffix only copies [+PARTICIPANT] features, then examples (14) and (15) do not clarify whether the person suffix cross references the subject or the object as they are both [+PARTICIPANT]. For this, we need to take a look at (17).

(17)	Himu-k	ma	m-dzir-u.	
	3SG-ERG	1SG.NOM	1-see-PAST.3	
	'S/he saw me.'			

In (17), the subject is third person while the object is first person. Unlike the number suffix, the person suffix still cross-references the subject. Note that omnivorous number is still possible in cases when the person values of the subject and the object do not match, as in (18), where the subject is [-PARTICIPANT] and the object is [+PARTICIPANT].

(18)	Himu-k	şk'u	m-dzir-es.	
	3SG-ERG	1PL.NOM	1-see-PAST.3PL	
	'S/he saw us.' <sup>4</sup>			

There are several ways to interpret the difference between the behavior of the person and number suffixes in Laz. One way to interpret this difference is to argue that person features are specified in a binary way while number features are specified privatively (Nevins 2011). Thus, the person suffix, which is on T (as supported by fusion with tense) always agrees with the subject because it can always be valued by the binary features on nominals. Number features on the other hand are privative. [PLURAL] is marked on nominals while [SINGULAR] isn't. Thus, the number probe can skip over the subject and agree with the object.

Another alternative is to posit a Single Agree vs. Multiple Agree difference between the number and the person suffixes. The person suffix always agrees once with the closest NP

---

<sup>4</sup>In Laz, plural and third person fuse into a single morpheme *-es*.

while the number suffix agrees with all the NPs within the local domain and receives all the number values. The realization of plural is due to the Elsewhere Principle. This second alternative is a bit problematic if person features are in fact privative. In that case, one would expect the person suffix to skip the subject in cases when the subject does not have any [PARTICIPANT] features. Yet, this never happens. One way to explain this is to invoke Baker's (2008) SCOPA which imposes a structural distance restriction on person agreement. While SCOPA fails to capture object agreement facts in Kurmanji, it is a valid generalization for a number of languages. I will leave the discussion of whether person features in Laz are privative or binary to the next section. Let me return to my main focus in this section: person and number probes are highly specified and they work independently.

The data above indicate that, in Laz, distinct agreement suffixes are specified for  $\pi$  (PARTICIPANT) and # (NUMBER), and they can skip irrelevant syntactic objects, even phrases with other  $\varphi$ -features, to find the relevant syntactic objects. This accounts for the CASE-INSENSITIVE nature of Laz. Case does not block agreement in Laz because it is not an intervener in the feature Relativized Minimality sense.

Let me illustrate this with an example. In (14), repeated below as (19), the subject is first person singular while the object is second person plural. The person suffix agrees with the subject in person while the number suffix cross-references the object which is plural. Let us put the object marking on the verbal prefix aside for the time being.

- (19) Ma t'k'va g-dzir-i-t.  
 1SG.ERG 2PL.NOM 2-see-PAST. $\pi$ -PL  
 'I saw you (pl).'

The relevant structure of (19) is given in (20). It should be noted that a number of factors like head directionality and locality domains (phases) are ignored in this illustration. I come back to those issues in Section 3.

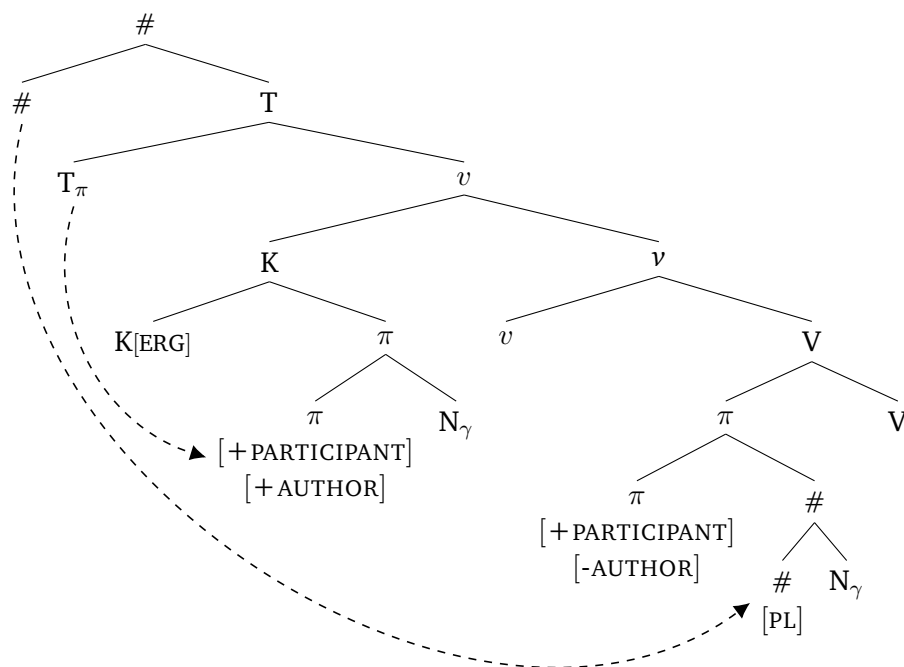
(20) *Relativized Probing in Laz*

In (20), the  $\pi$  probe which is looking for a [PARTICIPANT] feature is on T. This is supported by the fact that, in Laz, the person suffix carries both person and tense information. Upon merging into the structure, it probes down to find the closest phrase with [PARTICIPANT] features. The closest phrase with a [PARTICIPANT] feature is the external argument which has a  $\pi$  embedded under a K. Since the probe is looking for a [PARTICIPANT] feature, it skips past all the irrelevant phrases including K to find the [PARTICIPANT] feature on the external argument. Next, the #-probe is introduced. Like  $\pi$ , # is looking for a phrase with number features. Assuming that number is privative in Laz, the subject does not have any number features. Therefore, the #-probe skips over all the irrelevant features to find the PL on the internal argument.

The KP account provided above captures the agreement with overtly case marked nominals in Laz but needs a qualification. There is a technical locality issue that needs to be addressed. In Chomsky (2000), the standard assumption regarding the locality of Agree has been stated in terms of closest c-command, which is a version of the Minimal Link Condition (Chomsky 1995) and Relativized Minimality (Rizzi 1990).

- (21) A syntactic object  $\alpha$  may enter into a relation with another syntactic object  $\beta$  iff there is no  $\gamma$  that meets the requirement(s) of  $\alpha$  such that  $\alpha$  c-commands  $\gamma$  and  $\gamma$  c-commands  $\beta$ .

The locality condition in (21) translates into the closest c-command condition for Agree described below.

- (22) Given a probe P and two potential goals  $G_1$  and  $G_2$   
 $G_1$  is closer to P than  $G_2$  if  
 P c-commands  $G_1$ ,  
 $G_1$  c-commands  $G_2$ , and  
 $G_2$  does not c-command  $G_1$

Given the locality definitions in (21) and (22), Agree should not be able to determine the closest  $\pi$  goal in (20). In (20), the participant phrase  $\pi$  of the subject is under KP and therefore it does not c-command the participant phrase of the object (or vice versa). By the definitions of closest c-command, the  $\pi$  in the subject is not closer to the probe than the  $\pi$  in the object because there is no c-command relation between the two  $\pi$  phrases.

The locality issue is non-trivial and comes with any theory that decomposes atomic syntactic objects into syntactically complex objects. The problem persists even in configurations where the nominal phrase does not have a KP layer at all. In such cases,  $\pi$  of the subject can be in a position to c-command the  $\pi$  of the object, but number and gender phrases cannot unless these features somehow percolate up to the top of the nominal phrase.<sup>5</sup> This however is at odds with the partial agreement facts discussed in Chapter 2. This is a general locality problem which goes beyond the domain of agreement and requires systematic research. In the remainder of this section, I provide a loosened definition of locality that solves the problem for Agree purposes. In the next section, I also interject an alternative model of distance based on Minimal Search that solves the locality problem.

In order for the derivation proposed in (20) to work, the  $\pi$  phrase on the external

---

<sup>5</sup>See Danon (2011) for a proposal along these lines.



argument must be calculated to be closer than the  $\pi$  phrase on the internal argument. To capture this, I propose a locality measure based on extended projections. In Chapter 1, I assumed that all the heads in the extended projection of a nominal carry a [+N] feature that is introduced by the noun and copied to each head in the extended projection. This is why KPs are nominal in nature and they can block agreement with person, number, and gender features in languages like Kurmanji and Hindi among others. Now, I argue that extended projections are also relevant to calculating locality. I argue that in calculating the locality of individual  $\varphi$  features ( $\pi$ , #, GENDER), what matters is the extended projection to which the  $\varphi$ -feature belongs. In (20) the  $\pi$  phrase on the external argument is closer to the probe than the  $\pi$  feature on the internal argument because the former occurs in an extended projection that c-commands lower  $\pi$  phrase as well as its extended projection. This is stated in (23).

- (23) Given a probe P and two potential goals  $G_1$  and  $G_2$   
 $G_1$  is closer to P than  $G_2$  if  
 P c-commands  $G_1$ ,  
 the extended projection of  $G_1$  c-commands  $G_2$ , and  
 the extended projection of  $G_2$  does not c-command  $G_1$

This generalization fixes the c-command problem in (20). In the next section, I consider a novel alternative.

## 2 Minimal Search and Agree

The goal of this section is to introduce a novel and speculative definition of Minimal Search that solves the c-command problem observed in the previous section. Like any novel proposal, it needs to be approached with caution and tested empirically. My main motivation in introducing it here is to lay the groundwork for future research.

### 2.1 Minimal Search as an operation employed by Agree

As discussed in Section 2.1 of Chapter 2, any theory of agreement phenomena requires at least three main components. These include a notion of a dependent (probe/target), a

notion of a dependee (goal/controller), and a notion of a morpho-syntactic operation that can establish some relation between the dependent and a dependee. Each of these core components can also be complex. For example, a probe can consist of multiple features, just as a goal can consist of multiple features. Similarly, the operation Agree is also complex. The original formulation of Agree in Chomsky (1995) was relatively simple as it consisted of only two subcomponents, i) a relation builder and ii) a value copier. This was due to the stipulation that all agreement relations involve Spec-Head relations. Since, agreement between a head and its specifier can be established at the second merge (derivationally) or on Spec-Head (representationally), Agree did not need a notion of *searching/probing*.

With the advent of Long Distance Agree (Chomsky 2000, 2001; Polinsky and Potsdam 2001) the notion of searching/probing became an indispensable part of Agree. The notion of searching/probing became so essential that the dependent syntactic object has been called *probe* within much of the generative literature since Chomsky (2000).<sup>6</sup> In the earlier versions of the probe-goal system (Chomsky 2000, 2001), searching is defined as an inherent property of the operation Agree. Chomsky (2000) tries to reduce the syntactic operations to *Merge* and *Agree*. In this system, the most local relations (sisterhood) are established with *Merge* while long distance relations are established via *Agree*. Internal *Merge* requires *Agree* since *Agree* is the only search mechanism available.<sup>7</sup> In short, a concept of search was required to account for phenomena like long distance agreement and displacement; and this was built into the operation *Agree*.

In recent work, Chomsky (2013, 2014) abandoned the triggered view of movement where *Agree* is a precondition on movement. In this framework, movement (internal merge) is a corollary of labeling requirements and it is not dependent on *Agree*. On the contrary, movement happens in cases when *Agree* cannot apply and *Agree* prevents movement by establishing a “criterial position” (Rizzi 1997) for the moved element. Although the role of *Agree* has shifted and movement does not need *Agree* anymore, the need for a searching algorithm is still in place. In this framework both *Agree* and *Labeling* (which

---

<sup>6</sup>Some alternative descriptive terminology in the literature have been *target* (Corbett 2006) and *dependent*.

<sup>7</sup>This is the main motivation for all the triggered views of movement like Chomsky (2000, 2001), Miyagawa (2010), and van Urk (2015).

drives internal merge) depend on the operation Minimal Search. The search operation is so central and also inherent to syntactic theory that it often goes undefined. The literature is full of constraints on the locality and the directionality of the search (Relativized Minimality (Rizzi 1990), Phase Impenetrability Condition (Chomsky 2000, 2001, 2008), Downward Probing (Baker 2008; Chomsky 2008), Upward Probing (Baker 2008; Wurmbrand 2012; Zeijlstra 2012)), yet it is not clear how the searching occurs on the syntactic structures. To be more specific, it is not clear whether the search is done by a probe or something else (e.g. a dedicated operation that takes the probe as an input). Similarly, it is not clear whether the search operation checks every node between a probe and a potential goal or skips some of them. It is also unclear what skipping means. Does it mean visiting a specific node and not establishing a relationship when it is irrelevant or does it mean not visiting the node at all? In the following, I propose a version of Minimal Search that I borrow from graph theory and the computer science literature. Following Chomsky (2013, 2014), I assume that Minimal Search is an indispensable syntactic operation that serves other operations like Agree and the Labeling Algorithm. I also consider the possibility of Minimal Search being an operation that is not specific to the Language Faculty but a globally available cognitive functionality. This is in line with Chomsky's (2013) conjecture that Minimal Search is "presumably a third factor principle", where the third factor is described as in (24).

- (24) (III) organism-independent factors, including principles of natural law, which play a crucial role in development as in evolution: e.g., the laws of physics that determine that cells divide into spheres rather than cubes; and for computational systems like language, principles of computational efficiency that may well be reducible to laws of nature. (Chomsky 2013, p. 39)

Minimal Search is an operation that operates on syntactic structures that can be represented as binary branching trees.<sup>8</sup> Being a subtype of graphs, tree structures have been

---

<sup>8</sup>(Chomsky 2014) abandons tree representations and cautions against them. There is no evidence that syntactic structures are represented as trees in the human mind. However, tree structures are a well defined way of representing binary compositional structures. Presumably, any operation defined on trees should be translatable to some other representation that has a binary compositional structure, i.e. structures generated by Chomsky's Merge operation. Following the tradition in the generative syntax, I define Minimal Search based

extensively studied in the field of graph theory and computer science. The relevant tree structure for syntactic theory is the Binary Tree. One definition of Binary Tree is given in (25).

- (25) *Binary Tree* (Haggard, Schlipf, and Whitesides 2005, p. 381)  
 A binary tree is either a tree with no vertices or a rooted tree for which each vertex has at most two children. Each child of a vertex in a binary tree is designated as the left child of the vertex or the right child of the vertex (but not both).

Clearly, the definition of Binary Tree in (25) is similar to the syntactic tree structures in generative syntax, with a significant difference. In the recent generative tradition, linear order is generally assumed not to be a part of the narrow syntax (Chomsky 2013, 2014).<sup>9</sup> An order agnostic definition of a binary tree that can also capture the syntactic structures can be formulated as in (26).

- (26) *Binary Tree* (Haggard, Schlipf, and Whitesides 2005, p. 381)  
 A binary tree is either a tree with no vertices or a rooted tree for which each vertex has at most two children. Children of a vertex must be (set theoretically) disjoint.

Now that the definition of a tree is in place, let me discuss how Minimal Search can be formulated. Computer science knows of two basic types of searching on trees (and graphs in general): tree search and tree traversal. In a tree traversal, every node of the tree is visited, while in a tree search, visiting every node is not necessary. Given Relativized Minimality effects and economy of computation concerns, Minimal Search can be argued to be more like tree search than like tree traversal. Tree traversal is more likely to be used in linearization where every syntactic node needs to be visited for purposes of establishing a total order. See Kural (2005) for a theory of linearization based on tree traversal. Although search and traversal are defined in different ways, this does not necessarily entail that they

---

on the assumption that syntactic structures can be represented with trees, while also acknowledging the caveat that it might be misleading.

<sup>9</sup>Cf. proposals by Kayne (1994) (Linear Correspondence Axiom) and Phillips (2003) who assume linear order to be a part of syntax.

have to be built on distinct mechanisms. Tree search can be defined as a specific traversal method where traversal can be aborted upon finding the relevant node.<sup>10</sup>

Searching a tree involves finding a path from one node to another node. Two common algorithms used in computer science are *Depth First Search* and *Breadth First Search*. Descriptively speaking, in Depth First Search, search algorithm starts with the left child of the root node and iteratively searches all the nodes dominated by the left child before moving on to the right child of the root node. This is represented in (27).<sup>11</sup>

(27) *Depth First Search*

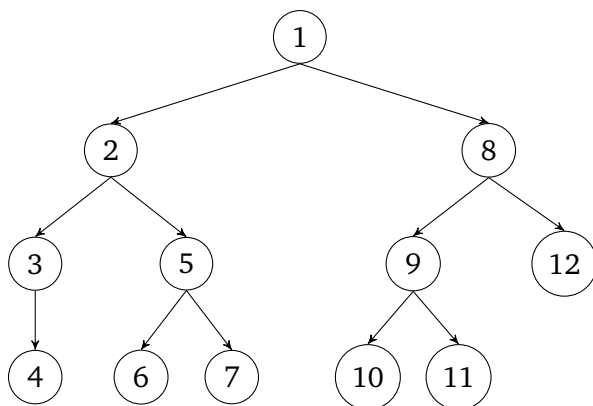

On the other hand, in Breadth First Search, the search algorithm iteratively searches every layer of the tree starting with the root node and iteratively searches the next layer of the tree incrementing the depth of search by one on each step. Like in Depth First Search,

<sup>10</sup>Defining search and traversal on the same basic operation seems to be the most parsimonious argument for a generalized graph/tree structure searching mechanism. However, there are various tree search algorithms that do not involve a search that follows a linear path. Some tree search algorithms can do much faster searches by indexing the nodes. Introduction of indexes is a clear violation of Inclusiveness, which is based on the principle of parsimony (Chomsky 2000, 2001, 2013, 2014). Similarly, proposing two separate search operations (traversal for linearization and search for Agree/Labeling) is also less parsimonious than having a single search algorithm further restricted by locality conditions like Relativized Minimality and the PIC in the syntax. On the other hand, indexing the nodes reduces the cost of computation at the search runtime. This is a classical case of competence – performance tension and requires empirical testing, which I won't attempt here. Instead, I just provide some ideas for future experimental research whose design is non-trivial. If tree search is just tree traversal with early abort, then the time required for Agree in a clause should always be less than or equal to the time required for the linearization of the entire clause. The only case where the times of the two operations can be equal would be when the syntactic objects that need to agree happen to be at the two ends of a clause (e.g. a VSO language where T agrees with the O). Although, theoretically plausible, this might be impossible to test empirically since it is hard to imagine a scenario where the time of Agree can be measured independently of linearization. A possible line of inquiry could involve investigating Agree violations and linearization violations to see if they induce similar reaction times or yield similar brain activity.

<sup>11</sup>One of the earliest versions of Depth First Search was investigated by Charles Pierre Trémaux in the 19th century.

searching involves linear order from left to right. The path of Breadth First Search is given in (28).

(28) *Breadth First Search*

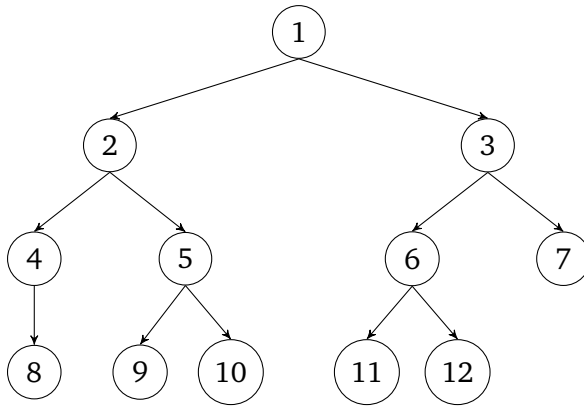

In the following, I argue that defining Minimal Search as a version of Depth First Search captures the locality problem discussed in the previous section.<sup>12</sup> Consider the following algorithm for Depth First Search.

(29) *Depth First Search*

- a. Mark all nodes *unvisited*
- b. Start with any node  $N$
- c. Mark  $N$  *visited*
- d. If  $N$  is a non-terminal, visit the left child  $N_1$  and mark it *visited* If there is no node  $N_n$  such that  $N_n$  is an unvisited child of  $N$ , visit  $N$ 's sibling  $N_2$
- e. Apply Steps c and d recursively
- f. Abort search when there is no node that is *unvisited*

The algorithm above restricts search to downward search. Given a node  $N$ , the search algorithm first searches all the nodes dominated by  $N$  and then traverses all the nodes that are dominated by  $N$ 's sibling  $N_2$  including  $N_2$ . This is similar to Minimal Search restricted by the c-command condition. The only difference is that the algorithm in (29) allows search

<sup>12</sup>Breadth First Search also captures the same facts. Whether Minimal Search is more like Depth First Search or Breadth First Search is a question worth further research.

within the starting node  $N$  if  $N$  is a non-terminal. In Chomsky (2000, 2001) *et seq.*, the domain of search is restricted to the c-command domain of a given node  $N$ . In contrast, the definition of Depth First Search is more comprehensive as it allows search inside the subtree dominated by  $N$  in addition to  $N$ 's c-command domain. There is no need to change the definition of Depth First Search to capture the c-command condition though. The c-command generalization follows from the definition of a probe. In Chapter 2, I defined a probe as a functional head with unvalued  $\varphi$ -features. Since a head is a terminal, the search space automatically becomes the c-command domain of the head. The only restriction that needs to be added to the system is a *Search Trigger*.

Like any other operation that is available for the computation, there needs to be a call function that would initiate the search. I assume that Minimal Search is triggered by probes (at least for Agree purposes).<sup>13</sup>

(30) Search Trigger (for Agree)

Minimal Search is triggered by probes only.<sup>14</sup>

The Depth First Search algorithm provided above captures all the requirements of Minimal Search that is needed for Agree. There is however one further issue that needs to be addressed before it can be employed as the search operation in the narrow syntax. The Depth First Search algorithm in (29) is based on a linear ordering of siblings. This is used in (31-d). When the search algorithm visits the children of a node, it starts with the left child. In the narrow syntax, there is no such linear ordering by hypothesis. Therefore, (31-d) must be modified to allow for the lack of linear order in syntax. I argue that this can be captured by tracking the derivational history of *Merge*. The goal is to search the specifier of a phrase before the head or the complement. In Chomsky (2014), the difference between a specifier and a complement is described through *first Merge* and *second Merge*.<sup>15</sup> Minimal

---

<sup>13</sup>An alternative is to argue that Minimal Search keeps applying iteratively throughout the entire derivation for other purposes like Labeling, Merge, etc. Whether Minimal Search is triggered by certain needs or keeps applying throughout the derivation is a question that needs further investigation.

<sup>14</sup>Kinjo (forthcoming), builds a novel theory of Agree based on Minimal Search where non-heads can also be probes and Minimal Search works in a top-down way. Whether the Depth First Search algorithm adopted here captures Kinjo's proposal or not needs further research. See Kinjo (forthcoming) for details.

<sup>15</sup>In cases of multiple specifiers, the Merge history can be recorded as *n*th Merge.

Search can exploit the Merge order instead of linear order to start with the “left” child of a node instead of the “right child”.<sup>16</sup> Now we are in a position to define Minimal Search as in (31).

- (31) Minimal Search
- a. Mark all nodes *unvisited*
  - b. Start with any node N
  - c. Mark N *visited*
  - d. If N is a non-terminal, visit N’s *last Merged* child  $N_1$  and mark it *visited* If there is no node  $N_n$  such that  $N_n$  is an unvisited child of N, visit N’s sibling  $N_2$
  - e. Apply Steps c and d recursively
  - f. Abort search when there is no node that is *unvisited*

Now that Minimal Search is defined, we can calculate the paths of search and calculate locality based on the distance spanned between a start node (probe) and any node that is in the search domain including the relevant ones, i.e. goals. Let me apply Minimal Search to the Laz structure discussed at the end of the previous section. I repeat a simplified version of structure (20) below as (32).

---

<sup>16</sup>The proposal attributes a special status to the heads. It assumes that specifiers and complements Merge *to* a head (asymmetric) not *with* a head (symmetric). Otherwise it would be impossible to choose between a specifier and a “bar” level that consists of the head and the complement because they would be merging at the same time and it would be impossible to pick one over the other. This idea is not novel or uncommon. The Labeling Algorithm works on the basis of head-phrase distinction where heads are given more prominence.

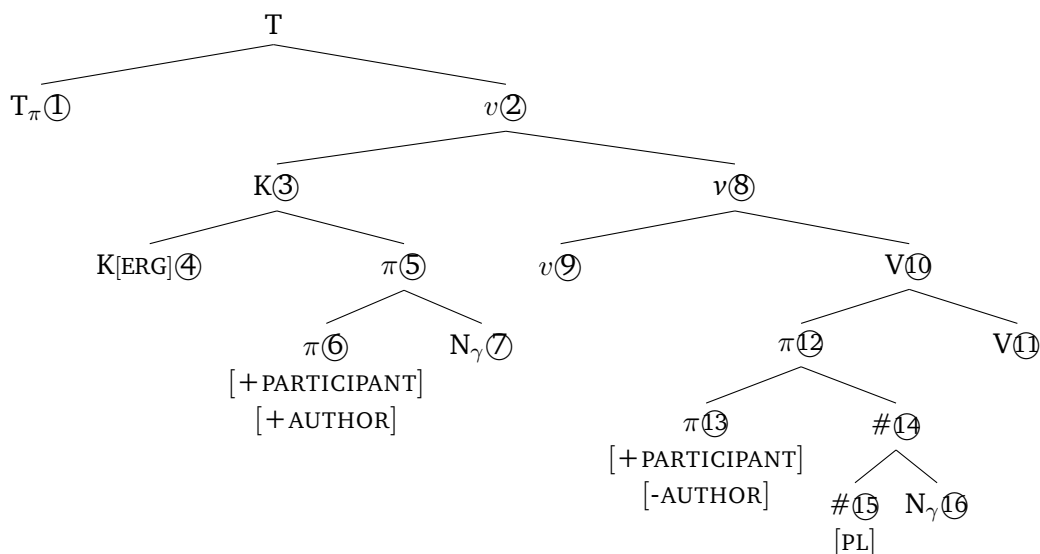

(32) *Minimal Search in Laz*

The tree in (32) illustrates the order in which Minimal Search traverses the tree. The circled numbers are not part of the narrow syntactic derivation or representation. They are only there for illustrating the path of Minimal Search. In (32), which is the representation of a Laz clause where T agrees with the ergative subject in person but not with the absolutive object, the  $\pi$  phrase of the subject does not c-command the  $\pi$  phrase of the object. By standard definitions of locality based on c-command, it is not possible to choose between the subject  $\pi$ P and the object  $\pi$ P. On the other hand, with the definition of Minimal Search given in (31), the subject  $\pi$ P is the closer to the probe than the object  $\pi$ P as the path to subject  $\pi$ P spans less nodes than the path to the object  $\pi$ P. Not only is the path to the object  $\pi$ P (PathO) longer than the path to subject  $\pi$ P (PathS), but also PathO includes PathS.

Minimal Search, as defined above, is only a traversal algorithm that traverses the entire subtree starting with any node. In its current formulation, it cannot capture all the facts related to agreement or the facts of natural language in general. I argue that the purpose of Agree is to establish relationships between a probe and a goal. In order to do so, it employs Minimal Search to find potential goals. Minimal Search does not choose between two potential goals. The choice between two or more potential goals is made by Agree based on Relativized Minimality.<sup>17</sup> Relativized Minimality can be defined as a matter of

<sup>17</sup>The Phase Impenetrability Condition does not come into play in the calculation of multiple potential goals

shortest distance as in in (33) or in terms of path containment as in (34).

(33) Relativized Minimality – Shortest Distance

A syntactic object  $\alpha$  may enter into a relation with another syntactic object  $\beta$  iff there is no  $\gamma$  that meets the requirement(s) of  $\alpha$  such that the path between  $\alpha$  and  $\gamma$  spans less nodes than the path between  $\alpha$  and  $\beta$ .

(34) Relativized Minimality – Path Containment

A syntactic object  $\alpha$  may enter into a relation with another syntactic object  $\beta$  iff there is no  $\gamma$  that meets the requirement(s) of  $\alpha$  such that the path between  $\alpha$  and  $\gamma$  contains the path between  $\alpha$  and  $\beta$ .

Both of the definitions provided in (33) and (34) capture the agreement facts discussed throughout this dissertation. Choosing one over the other requires empirical testing, which I leave for further research.

Another important point regarding the nature of Minimal Search is the halting problem. The Minimal Search definition given in (31) makes it a traversal algorithm. One relevant question is this: Does Minimal Search abort upon finding a goal that matches the features of a probe or does it traverse the entire tree? Both alternatives are possible. It is possible to modify the Minimal Search algorithm to stop when the feature probed for is found. Alternatively, it can keep searching and find all the relevant nodes and leave the choice to Agree which can pick the goal based on constraints like Relativized Minimality and the availability of Multiple Agree. I assume that Minimal Search does not abort search upon finding the relevant goal. Instead, it traverses the entire phase. If a language has Multiple Agree, Agree establishes a relationship between a probe and all the goals. On the other hand, if a language has Single Agree, an Agree relation is established between a probe and the closest goal, where closest is defined via Relativized Minimality based on Minimal Search.

---

since the PIC establishes a hard boundary which prevents Minimal Search accessing the contents of another phase. As a result, potential goals inside a phase other than the probe are not visible to Agree by virtue of being invisible to Minimal Search. Hence, no choice is needed.

## 2.2 Section Summary

In this section, I proposed a definition of Minimal Search based on a Depth First Search algorithm employed in the fields of graph theory and computer science. I argued that Minimal Search is an operation that is employed by Agree to find all the potential goals of a probe. I have also proposed two versions of Relativized Minimality based on Minimal Search. Being a graph search algorithm, it is quite possible that Minimal Search is a globally available cognitive function that can be employed by any cognitive module that uses graph-like representations. In Chomsky's terms, Minimal Search can be a third factor employed by Agree as well as other syntactic operations like the Labeling Algorithm. The Minimal Search algorithm provided in this section accounts for the c-command issue from Laz structure in (20). While the proposal accounts for the c-command issue, it is quite speculative in its nature and needs further investigation, which I leave for future work. In the next section, I return to another curious phenomenon in Laz where omnivorous number agreement is parasitic on person agreement.

## 3 Parasitic Nature of Omnivorous Number Agreement

Person prefixes and omnivorous number interact in a very interesting way in Laz. Demirok (2013) observes that omnivorous plural agreement with an object is possible only when that object is also cross-referenced on the verb with a person prefix.

(35) Himu-k **ʃk'u** m-dzir-es.  
 3SG-ERG 1PL.NOM 1-see-PAST.3PL  
 'S/he saw us.'

(36) **Ma** bere-pe b-dzir-i-**\*t**.  
 1SG.ERG child-PL.NOM 1-see-PAST.π-**\*PL**  
 'I saw the children.'

(Demirok 2013, p. 183)

In (35), the object is 1PL and it is cross-referenced on the verb with the prefix *-m*. In this scenario, the verb shows plural agreement although the subject is singular. In (36), however, plural agreement is impossible despite the presence of a plural object. What is

different in this case is that the prefix cross-references the subject but not the object. (37) is another example where the direct object is plural but the verb does not show plural agreement, as the prefix cross-references the indirect object.

- (37) K'oçi-k ma t'k'va m-ots'ir-u/-\*es.  
 man-ERG 1SG.DAT 2PL.NOM 1-show-PAST.3SG/-3PL  
 'The man showed you (pl) to me.' (Demirok 2013, p. 184)

Demirok (2013) analyzes omnivorous number agreement as parasitic on person agreement. The proposal is that number agreement with a noun phrase is possible only if that NP undergoes person agreement as well. This works for the examples provided above but fails to capture the possibility of plural agreement with third person plural subjects, which are not cross-referenced on the verb via person prefixes as in (38).

- (38) Bere-pe-k ma m-dzir-es.  
 childPL-ERG 1SG.NOM 1-see-3PL  
 'The children saw me.' (Demirok 2013, p. 183)

Demirok (2013) also notes that nominative third person subjects can be agreed with in number. Hence, it is not the case that third plural NPs cannot be agreed with.

- (39) Andğa iri bere-pe mektebi-şe menda-xt'-es.  
 today all child-PL.NOM school-ABL PV-go-3PL  
 'Today, all the children wen to school.' (Öztürk and Pöchtrager 2011, p. 33)

Earlier, I argued that omnivorous agreement examples, where the person suffix cross-references the subject while the number suffix cross-references the object, indicate that number and person probes are separate in Laz. This allows a number or person probe to ignore case and see inside a KP, resulting in full agreement with case marked nominals. The parasitic nature of number agreement with object NPs seems to complicate my claim that number and person probes are highly specified and independent.

In the following, I argue that number agreement is not parasitic on person agreement. Rather, omnivorous number agreement in Laz is a result of clitic doubling and number agreement is with the doubling clitic but not with the actual direct object. The impossibility

of agreement with third person plural objects directly is due to the Phase Impenetrability condition. I suggest that “agreement” prefixes in Laz are in fact clitics. Omnivorous number agreement is possible only when the object is cliticized to the *v*P/ ApplP. Otherwise, the object cannot be agreed with, due to the PIC. The structure of omnivorous number agreement in Laz is roughly as in (40).

(40) *Omnivorous Number Agreement and Clitic Doubling*

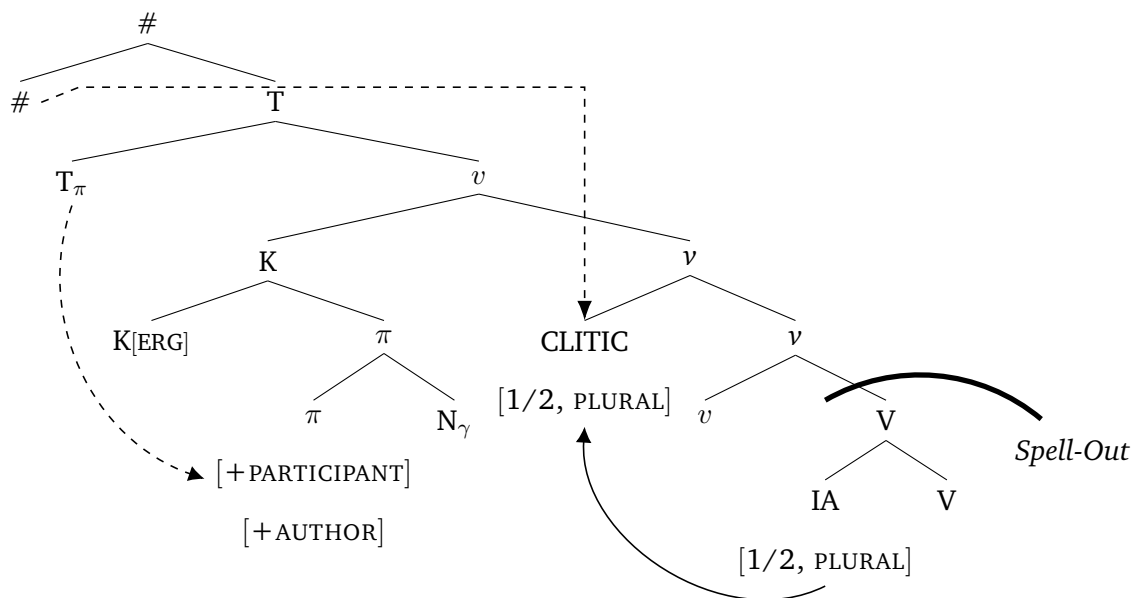

Only first and second person pronouns can be cross-referenced as prefixes in Laz. In other words, only first and second person pronouns are clitic doubled. When the object cannot be clitic doubled, the #-probe cannot access it due to the PIC. This is why omnivorous number agreement is parasitic on “person” prefixes in Laz. In the following, I discuss “person” prefixes in Laz and highlight a few differences between “person” prefixes and “person” suffixes which support the clitic status of prefixes as opposed to suffixes which are instantiation of true agreement.

#### 4 Person Prefixes in Laz

Person prefixes in Laz cross-reference the person features of different arguments in a clause. In intransitive clauses, the person prefix cross-references the sole argument of the clause if

the argument is first person.

- (41) **Ma v-inçir-i**  
 1SG.ERG 1S-swim-PAST.π  
 ‘I swam.’ (Atlamaz 2013)

When the subject is second or third person, there is no overt person prefix.

- (42) a. **Si inçir-i**  
 2SG.ERG swim-PAST.π  
 ‘You swam.’ (Atlamaz 2013)
- b. **Himu-k inçir-u**  
 3SG-ERG swim-PAST.3SG  
 ‘S/he swam.’ (Atlamaz 2013)

In transitive clauses, cross-referencing of arguments with prefixes follows a “cyclic” pattern (in the sense of Béjar and Rezac 2009). When the internal argument is first or second person, then the prefix cross-references the object.

- (43) **Si ma ce-m-ç-i**  
 2SG.ERG 1SG.NOM PV-1O-beat-PAST.π  
 ‘You beat me.’ (Atlamaz 2013)

- (44) **Ma si ce-k-ç-i**  
 1SG.ERG 2SG.NOM PV-2O-beat-PAST.π  
 ‘I beat you.’ (Atlamaz 2013)

When the object is third person and the subject is first person, the prefix cross-references the subject.

- (45) **Ma him ce-p-ç-i**  
 1SG.ERG 3SG.NOM PV-1S-beat-PAST.π  
 ‘I beat him/her.’ (Atlamaz 2013)

It should be noted that the prefix triggered by first person objects are different from the one triggered by first person subjects. In (43), the prefix is *-m* while in (45) and (41), the prefix is *-p/v*. On the surface, the presence vs. absence of the prefix and its form correlates with

the grammatical function of the cross-referenced nominal. The full paradigm is given in (46).<sup>18</sup> The alternating forms of 1s (*v/p/f/b*) and 2o (*k/g*) are phonologically determined (Öztürk and Pöchtrager 2011).

(46)	PERSON	SUBJECT (S-PREFIX)	OBJECT (O-PREFIX)
	1	-v/p/f/b	-m
	2	∅	-k/g
	3	∅	∅

The cyclic nature of cross-referencing arguments on prefixes includes affected arguments of ditransitives. The hierarchy of privilege for the prefix is IO > DO > S as illustrated by (47).<sup>19</sup>

- (47) a. Himu-k si            **ma**        **m-o-dzir-u.**  
 3SG-ERG 2SG.NOM 1SG.DAT 1O-APPL-see-PAST.3SG  
 ‘S/he showed you to me.’
- b. Ma        **si**            himu-s    **g-o-dzir-i.**  
 1SG.ERG 2SG.NOM 3SG-DAT 2O-APPL-see-PAST.π  
 ‘I showed you to her/him.’
- c. **Ma**        him        himu-s    **v-o-dzir-i.**  
 1SG.ERG 3SG.NOM 3SG-DAT 1S-APPL-see-PAST.π  
 ‘I showed her/him to her/him.’
- (Atlamaz 2013)

In (47), the indirect object is first person and it gets cross-referenced on the verb with an object prefix. In (47-b), the indirect object is third person, which does not trigger a prefix, and the privilege moves to the direct object. Finally in (47-c), both of the internal arguments are incapable of triggering a prefix on the verb. In this scenario, the subject is cross-referenced on the verb with a subject prefix. In scenarios where all the arguments are third person or the subject is second person while the objects are third person, the verb does not have any prefix cross-referencing the arguments. This is shown in (48).

<sup>18</sup>A more precise description of person prefixes would make reference to thematic roles. All the intransitive subjects (Agent/Theme) and Agentive transitive subjects are marked with an S-PREFIX. On the other hand, experiencer dative subjects are cross-referenced with O-PREFIX. All other arguments are cross-referenced with an O-PREFIX. See Erguvanlı Taylan and Öztürk (2014) and Holisky (1991) for further details.

<sup>19</sup>It is worth noting that (47-a) is a Person Case Constraint violation, but the sentence is still grammatical.

- (48) Himu-k him himu-s o-dzir-u.  
 3SG-ERG 3SG.NOM 3SG-DAT APPL-see-PAST.3SG  
 ‘S/he showed her/him to her/him.’

In Atlamaz (2013), I analyzed the “person” prefixes as agreement and proposed an account within the tenets of Cyclic Agree (Béjar and Rezac 2009). Now, I propose that these prefixes are in fact clitics, not agreement morphemes. In the following, I discuss some arguments in favor of a clitic analysis for prefixes in Laz.

The first argument in favor of Laz prefixes being clitics comes from the morphological shape of prefixes compared to suffixes. Prefixes in Laz look like pronouns whereas  $\pi$ -suffixes in Laz do not. For example, the first person object prefix is *m-*, which is the same consonant as the first person pronoun *ma*. Similarly, the second person object prefix is *k/g-* which is similar to the second consonant in the second plural pronoun *T’k’va*. The allative/ablative form of second pronoun is *sk’aninde* and it has the consonant *k’* in it. This form is a complex consisting of the morphologically conditioned form of second singular *sk’an* and the allative/ablative suffix *-inde*. The table below presents prefixes with the pronouns they cross-reference. Third person is excluded as it does not trigger any prefixes.

(49)	PERSON	PREFIX		PRONOUN		ALLATIVE PRONOUN	
		SBJ	OBJ	SG	PL	SG	PL
1	v/f/p/b	<b>m</b>	<b>ma</b>	ʃk’u	ʃk’iminde	ʃk’uninde	
2	∅	<b>k/g</b>	<b>si</b>	t’k’va	sk’aninde	t’k’vaninde	

Unlike prefixes,  $\pi$ -suffixes do not share anything tangible with the pronouns. The first and second person suffix in past tense is *i* while third person is  $\emptyset$ . In other tenses, first and second person suffix is  $\emptyset$  while third person is *u*. Person suffixes fuse with tense (and/or number in 3PL), while prefixes do not fuse with anything.

The second argument in favor of prefixes being clitics is due to the “cyclic” nature of prefixes. In Atlamaz (2013), I argued that third person pronouns do not have PERSON nodes. Hence, they cannot value the PERSON feature of the prefix. This allows the prefix probe to cyclically expand its search space until it finds a nominal with PERSON features. This accounts for the data in (47) where the prefix cross-references the first argument with



PARTICIPANT features following the access order of IO > DO > S. The order is not imposed, it can be derived from the structure.

While the Cyclic Agree proposal accounts for the behavior of prefixes in isolation, it fails to capture the difference between suffixes and prefixes in terms of “skipping over” the irrelevant features. The Cyclic Agree view is based on the assumption that third person pronouns are deficient in terms of person features, which allows the prefix to skip over third person pronouns and find the closest NP with a PARTICIPANT feature. Nevertheless, this “skipping over” is not possible for suffixes at all. This can be seen in (50), for example.

- (50) Himu-k ma m-dzir-u / \*-i.  
 3SG-ERG 1SG.NOM 1O-see-PAST.3SG / \*- $\pi$   
 ‘S/he saw me.’

If third person pronouns in Laz lacked a person feature, then we would expect the person suffix to skip over the third person subject and agree with the first person object. Compare (50) with (51) where the subject is first person while the object is third person. This time the prefix can “skip over” the object to find the subject. If the prefix were the result of person agreement, it should not be able to skip over the object.

- (51) Ma him b-dzir-i.  
 1SG.ERG 3SG.NOM 1S-see- $\pi$   
 ‘I saw her/him.’

A third argument in favor of prefixes as clitics is their dependency on the grammatical function of the NPs they cross-reference. The form of the prefix changes depending on whether the cross-referenced object is a subject or an object or a dative subject. Intransitive subjects and ergative subjects are cross-referenced via the S-prefixes while other arguments are cross-referenced via O-suffixes. Prefixes seem to copy more information from an NP than suffixes do. While suffixes copy PARTICIPANT features only, clitics are “coarse” as Preminger (2014) puts it. Clitics copy a reduced form of the pronoun but they still carry more features than  $\varphi$ -features. For example, in some languages clitics copy case information. In Laz, nominative and ergative subjects can trigger S-suffixes while dative subjects, and

internal objects trigger O-suffixes even when they are nominative.

I speculate that prefixes carry phi features as well as some other information regarding the grammatical function of the argument. This cannot be morphological case because a nominative argument can trigger an S-prefix or an O-prefix depending on its grammatical function. For example, in (52) the subject is nominative and triggers an S-prefix.

- (52) Ma        b-ğur-i  
       1SG.NOM 1S-die-PAST.1  
       'I died.' (Demirok 2013)

On the other hand, the nominative object in (53) triggers an O-prefix.

- (53) Si        **ma**        ce-**m**-ç-i  
       2SG.ERG 1SG.NOM PV-1O-beat-PAST.π  
       'You beat me.' (Atlamaz 2013)

It should be noted that thematic marking cannot be the answer either. The subject in (52) and the object in (53) are both theme arguments but they trigger different prefixes.

What could the answer possibly be? There are at least two possibilities. The first possibility is that Laz (or language in general) has a surface case system and an abstract licensing mechanism that does not always overlap with the surface morphological case. Laz is underlyingly (syntactically) a tripartite language which is reflected on clitics. There is some similar evidence in Kashmiri where the case marking on clitics do not overlap with the case marking on nominals. The second alternative is to argue that clitics are assigned case independently of the NPs they double. I leave this for future research.

To sum up, in this section, I have shown that Laz has highly specified agreement probes that can operate independently of each other. Since these highly specified probes are specified for particular features like [PARTICIPANT] and [NUMBER], they have the ability to skip over any category that is not relevant. That includes KPs (in the absence of fusion). This makes agreement in Laz CASE-INSENSITIVE.

## 5 Turkish

Turkish (ISO 639-3 [tur]) has an accusative alignment, where subjects are morphologically unmarked (traditionally called nominative) and the direct objects of transitive clauses get accusative case when specific. In simple cases, the verb agrees with the unmarked subject in person and number.

- (54)
- a. **Ben** Mehmet-i gör-dü-**m**.  
1SG Mehmet-ACC see-PAST-1  
'I saw Mehmet.'
  - b. **Sen** Mehmet-i gör-dü-**n**.  
2SG Mehmet-ACC see-PAST-2  
'You saw Mehmet.'
  - c. **O** Mehmet-i gör-dü.  
3SG Mehmet-ACC see-PAST  
'S/he saw Mehmet.'
  - d. **B-iz** Mehmet-i gör-dü-**k**.  
1-PL Mehmet-ACC see-PAST-1PL  
'We saw Mehmet.'
  - e. **S-iz** Mehmet-i gör-dü-**nüz**.  
2-PL Mehmet-ACC see-PAST-2PL  
'Y'all saw Mehmet.'
  - f. **On-lar** Mehmet-i gör-dü-**ler**.  
3-PL Mehmet-ACC see-PAST-PL  
'They saw Mehmet.'

Turkish is a heavily agglutinative language and unlike in Kurmanji, case and number do not fuse into a single morpheme. Plurality is expressed by two different morphemes that are contextually conditioned, which are invariant (apart from vowel harmony). The plural marker on common nouns and third person pronouns is the *lar* suffix.<sup>20</sup>

---

<sup>20</sup>The representation of the vowels with capital letters is a convention in the Turkish literature to indicate a vowel that undergoes vowel harmony.

(55)	NOMINAL	SINGULAR	PLURAL
	house	<i>ev</i>	<i>ev-ler</i>
	car	<i>araba</i>	<i>araba-lar</i>
	3RD PERSON	<i>o</i>	<i>on-lar</i>

*lar* is not used on first or second person pronouns. The singular and plural forms of participant pronouns are given below.

(56)	NOMINAL	SINGULAR	PLURAL
	1ST PERSON	<i>ben</i>	<i>biz</i>
	2ND PERSON	<i>sen</i>	<i>siz</i>

One relevant question is about the analysis of the plural morpheme on participant pronouns. I argue that *iz* is a contextually determined form of the plural morpheme rather than being a fusion of multiple features including person. I analyze the plural participant pronouns as in (64).

- (57)
- a. *b-iz*  
1 - PL
  - b. *s-iz*  
2 - PL

This claim is also supported by the agreement morphology on verbs. Turkish verbal agreement has two paradigms. I provided examples of one of the paradigms above in (54). Some of the verbal agreement morphology shows similarity to the actual person and number features on pronouns and nominals.

Let us start by analyzing the singular versus plural third person pronouns and nominals.

- (58)
- a. **o** Mehmet-i gör-dü.  
3.SG Mehmet-ACC see-PAST  
'S/he saw Mehmet.'
  - b. **on-lar** Mehmet-i gör-dü-ler.  
3-PL Mehmet-ACC see-PAST-PL  
'They saw Mehmet.'

- (59) a. çocuk Mehmet-i gör-dü.  
 kid Mehmet-ACC see-PAST  
 'The kid saw Mehmet.'
- b. çocuk-**lar** Mehmet-i gör-dü-**ler**.  
 kid-PL Mehmet-ACC see-PAST-PL  
 'The kids saw Mehmet.'

The nominal plural morpheme is the same as the verbal plural morpheme (ignoring vowel harmony). Similar effects are observed on second person pronouns.

- (60) a. **sen** Mehmet-i gör-dü-**n**.  
 2.SG Mehmet-ACC see-PAST-2  
 'You saw Mehmet.'
- b. **s-iz** Mehmet-i gör-dü-**n-üz**.  
 2-PL Mehmet-ACC see-PAST-2-PL  
 'Y'all saw Mehmet.'

The plural morpheme on the verb in (60-b) is the same morpheme as the plural pronoun, namely *iz*. The first person plural example in (54-d) seems to violate the generalization that the verbal number agreement is the same as or similar to the number marking on the nominal. This is shown below.

- (61) a. **Ben** Mehmet-i gör-dü-**m**.  
 1SG Mehmet-ACC see-PAST-1  
 'I saw Mehmet.'
- b. **B-iz** Mehmet-i gör-dü-**k**.  
 1-PL Mehmet-ACC see-PAST-1PL  
 'We saw Mehmet.'

In (61-b), *k* suffix on the verb represents both person and number information [1, PL]. However, as I mentioned above, Turkish has two paradigms of verbal agreement. The second paradigm is illustrated below in (62).

- (62) a. **Ben** Mehmet-i gör-üyor-**um**.  
1SG Mehmet-ACC see-PROG-1  
'I see Mehmet.'
- b. **Sen** Mehmet-i gör-üyor-**sun**.  
2SG Mehmet-ACC see-PROG-2  
'You see Mehmet.'
- c. **O** Mehmet-i gör-üyor.  
3SG Mehmet-ACC see-PROG  
'S/he sees Mehmet.'
- d. **B-iz** Mehmet-i gör-üyor-**uz**.  
1-PL Mehmet-ACC see-PROG-1PL  
'We see Mehmet.'
- e. **S-iz** Mehmet-i gör-üyor-**sun-uz**.  
2-PL Mehmet-ACC see-PROG-2-PL  
'Y'all see Mehmet.'
- f. **On-lar** Mehmet-i gör-üyor-**lar**.  
3-PL Mehmet-ACC see-PROG-PL  
'They see Mehmet.'

In this second paradigm, when the subject is first person plural, the verbal agreement is *Iz*, just like in second person plural as well as the pronouns. The table below summarizes the agreement morphology from the two paradigms.

(63)	GLOSS	PRONOUN	PARADIGM 1	PARADIGM 2
	1SG	<i>ben</i>	<i>-(I)m</i>	<i>-(I)m</i>
	2SG	<i>sen</i>	<i>-n</i>	<i>-s(I)n</i>
	3SG	<i>o</i>	<i>-∅</i>	<i>-lAr</i>
	1PL	<i>biz</i>	<i>-k</i>	<i>-Iz</i>
	2PL	<i>siz</i>	<i>-niz</i>	<i>-sInIz</i>
	3PL	<i>onlar</i>	<i>-lAr</i>	<i>-lAr</i>

Given that in a fair number of cases number and person morphemes are distinguishable on the verb, I assume that person and number are two distinct probes in Turkish. Most of the time, these morphemes do not fuse with anything but in certain contexts, they can fuse into a single surface form as is the case in first person plural in Paradigm 1. In the following, I provide Vocabulary Insertion rules for the person and number morphemes on the verbs in Turkish. However, first, let me provide further details about the two paradigms.

The two paradigms of agreement have been referred to as the verbal paradigm (Paradigm 1) and the nominal paradigm (Paradigm 2) in the literature (Göksel 2005; Good and Yu 2005) because Paradigm 1 occurs only with verbal predicates while Paradigm 2 occurs with nominal predicates as well as verbal predicates. The examples below illustrate the constructions in which each of these paradigms occur.

## (64) Paradigm 1

- |    |  |                    |
|----|--|--------------------|
| a. | git-ti-k<br>go-PAST-1PL<br>'We went'                           | <i>Past Tense</i>  |
| b. | git-se-k<br>go-COND/OPT-1PL<br>'If we go, .../I wish we went.' | <i>Conditional</i> |

## (65) Paradigm 2

- |    |   |                                |
|----|---|--------------------------------|
| a. | gid-iyor-Ø-uz<br>go-PROG-1-PL<br>'We are going'                       | <i>Present Progressive</i>     |
| b. | gid-er-Ø-iz<br>go-AOR-1-PL<br>'We go. / We shall go.'                 | <i>Aorist - Present Simple</i> |
| c. | iyi-Ø-yiz<br>good-1-PL<br>'We are good'                               | <i>Non-verbal predicate</i>    |
| d. | gid-iyor-muş-Ø-uz<br>go-PROG-EVID-1-PL<br>'Apparently, we are going.' | <i>Evidential</i>              |
| e. | gid-eceğ-Ø-iz<br>go-FUT-1-PL<br>'We will go.'                         | <i>Future</i>                  |

The table below summarizes the constructions in which each paradigm occurs.

(66)	PARADIGM 1	PARADIGM 2
	Past	Progressive
	Conditional	Aorist
		Non-verbal
		Evidential
		Future

Highlighting a few key differences between Paradigm 1 and Paradigm 2 and applying the diagnostics proposed by Zwicky and Pullum (1983), Good and Yu (2005) argue that Paradigm 1 morphemes are affixes whereas Paradigm 2 morphemes are clitics. The first criterion is that the clitics can exhibit a low degree of selection with respect to their hosts, as compared to affixes. The distribution in (66) indicates that Paradigm 2 morphemes are more likely to be clitics.

Another piece of evidence Good and Yu provide comes from suspended affixation in Turkish. Suspended affixation is the phenomenon in Turkish where a morphemic ending is optionally omitted from all the conjuncts except for the last one in a conjunction phrase (Kabak 2007; Kornfilt 1996, 2012; Lewis 1967). Here are some examples.

- (67) a. genç ve hızlı-Ø-yız  
young and fast-1-PL  
'We are young and fast.'
- b. genc-Ø-iz ve hızlı-Ø-yız  
young-1-PL and fast-1-PL  
'We are young and fast.'
- (68) a. gid-iyor ve gel-iyor-Ø-uz  
go-PROG and come-PROG-1-PL  
'We are going and coming.'
- b. gid-iyor-Ø-uz ve gel-iyor-Ø-uz  
go-PROG-1-PL and come-PROG-1-PL  
'We are going and coming.'

While suspended affixation is possible with Paradigm 2 morphemes (as in (67)-(68)), it is not possible with Paradigm 1 morphemes. This is shown in (69).



- (69) a. \*git-ti ve gel-di-k  
 go-PAST and come-PAST-1PL  
 'We went and came back.'
- b. git-ti-k ve gel-di-k  
 go-PAST-1PL and come-PAST-1PL  
 'We went and came back.'

Another key difference, not discussed in Good and Yu (2005), is the position of the agreement/clitic morphemes with respect to the question particle *mi*. While Paradigm 1 morphemes precede the question particle ((70)), Paradigm 2 morphemes follow it ((71)).

- (70) git-ti-k **mi**  
 go-PAST-1PL Q  
 'Did we go?'

- (71) gid-iyor **mu**-Ø-yuz  
 go-PROG Q-1-PL  
 'Are we going?'

Clearly, Paradigm 1 and Paradigm 2 have different properties and distributions, and the difference could be due to the affix vs clitic nature of the two paradigms as proposed by Good and Yu. I will not focus on the cliticness or the affixhood of the two paradigms, not because it is irrelevant or insignificant, but primarily because I do not have a theory of clitics. Instead, I will focus on the relative positions of these agreeing morphemes before providing a set of Vocabulary Insertion Rules for agreement morphemes in Turkish. Let me start with Paradigm 1.

As shown above in (64), Paradigm 1 agreement morphemes attach to the past tense morpheme as well as the conditional morpheme. The examples are repeated below for convenience.

- (72) Paradigm 1
- a. git-ti-k  
 go-PAST-1PL  
 'We went'

*Past Tense*

- b. git-se-k  
 go-COND/OPT-1PL  
 'If we go, .../I wish we went.' *Conditional*

In (72-a), the first person plural morpheme *-k* attaches to the past tense morpheme *-ti* while in (72-b) it attaches to the conditional/optative/subjunctive mood marker *-se*. There are cases when both the past tense morpheme and the conditional/optative/subjunctive morpheme occur in the same clause. The order of the past tense and the mood marker can vary with some significance in meaning, and the agreement morpheme always attaches to the rightmost of the two elements.

- (73) git-ti-yse-k  
 go-PAST-MOOD-1PL  
 'If we have gone,' *indicative reading*
- (74) git-se-ydi-k  
 go-MOOD-PAST-1PL  
 'If we went / I wish we went.' *subjunctive reading*

In (73), the mood marker takes scope over the tense marker and we get an indicative reading in which the conditional entails that the event has already taken place or there is a possibility that the event took place. In (74), the tense marker takes scope over the mood marker and we get a subjunctive reading where the entailment is that the event did not happen. The indicative/subjunctive distinction is discussed in von Stechow (2012). The following examples from von Stechow (2012) (originally due to Adams (1970)) in English illustrate the distinction.

- (75) If Oswald didn't kill Kennedy, someone else did. *indicative*
- (76) If Oswald hadn't killed Kennedy, someone else would have. *subjunctive*

The details of the subjunctive and indicative conditionals and its analysis is obviously beyond the scope of this dissertation. What matters in the examples in (73) and (74) is that the agreement morpheme does not change its position along with the tense and subjunctive

morphemes. This indicates that the agreement probe is not on T or Mood. Instead, it is located higher than both T and Mood and possibly projects its own head. In the following, I assume that the Paradigm 1 agreement probes in Turkish project their own heads above T and Mood. Earlier, I showed that the agreement morphemes in Turkish are composite. In many instances number can be separated from person and the person morpheme appears to the left of the number morpheme. Given that Turkish is a head final language, I assume that the relevant structure of a clause with Paradigm 1 agreement is as in (77).

(77) *Clausal Structure - Paradigm 1*

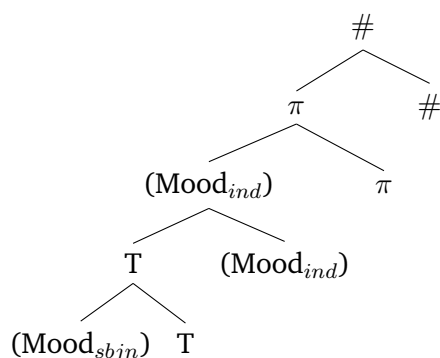

Next let us take a look at Paradigm 2. The agreeing morpheme<sup>21</sup> can attach to a variety of other morphemes including aspect, tense, and evidentiality. Again, given that the agreeing morpheme can attach to a variety of different heads, I assume that the probe is not on Asp, T, or Evid, etc. Instead, it projects its own head. Given that Turkish is a head final language, I assume that the probe attaches higher than any of the heads that appear on its left. Paradigm 2 agreement morphemes are the rightmost elements on the verb and they follow Asp, Tense, Evidentiality as well as the Q particle which can be associated with the Force of the clause. Without going into much detail, I assume that Paradigm 2 morphemes are the realization of agreement above C (or whatever the highest head in the clause is). There is some evidence to support the proposal that the Paradigm 2 morphemes are at the C level. I discuss that below along with the interaction of agreement and overt case in Turkish. The proposed structure for Paradigm 2 agreement is given in (78).

<sup>21</sup>I'm calling it the agreeing morpheme rather than the agreement morpheme or a clitic to remain agnostic about its status as a clitic or true agreement.

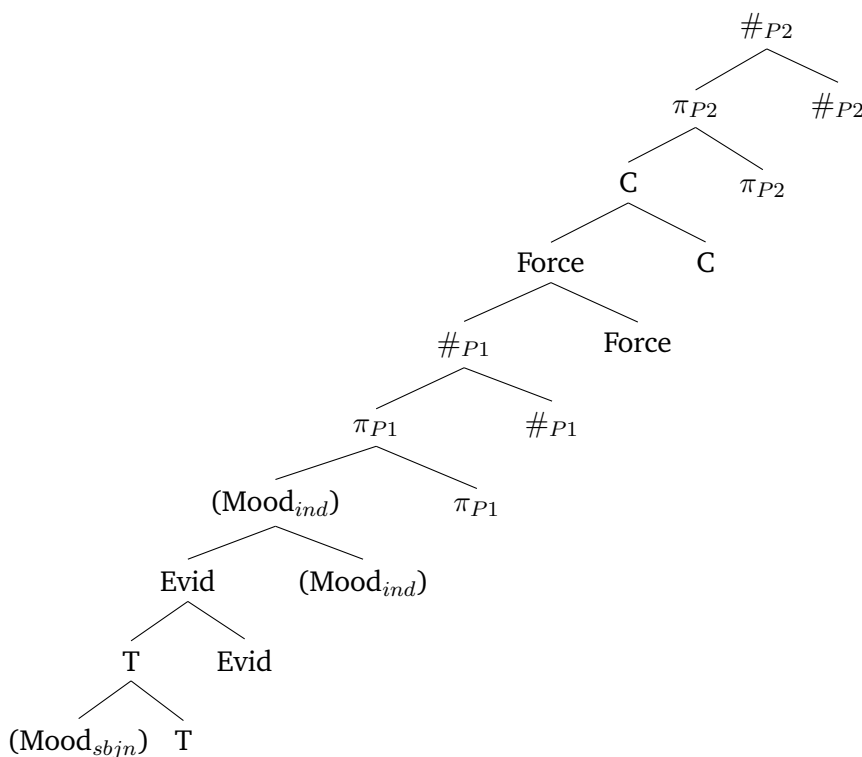
(78) *Clausal Structure - Paradigm 1*

The structure above illustrates the overall cartography. Some of elements listed on the structure cannot co-occur. For example, the evidentiality cannot co-occur with past tense (while it can with future tense).<sup>22</sup>

The two agreement paradigms never occur in the same clause.<sup>23</sup> Now that I have discussed the details of the two agreement paradigms, I can provide the disjunctive rule block that realizes the agreement patterns in Turkish.

<sup>22</sup> In fact, the evidential morpheme *-miş* can co-occur with the past tense morpheme as in (i). However, in such cases, it does not convey evidentiality. Instead it denotes perfectivity. See Göksel and Kerlake (2004) for further details.

(i) gel-miş-ti  
come-PERF-PAST  
'S/he had arrived.'

<sup>23</sup> While it is not clear why two agreement paradigms never occur in the same clause, it might be because, in Turkish, probes are related to phase heads and one phase can have only one agreement probe of one kind (i.e. one person probe and one number probe).

(79) *Disjunctive Rule Block for Agreement in Turkish*

- $\pi \longleftrightarrow -m / [\text{SPEAKER}]$   
 $\pi_{P1} \longleftrightarrow -n / [\text{PARTICIPANT}]$   
 $\pi_{P2} \longleftrightarrow -sIn / [\text{PARTICIPANT}]$   
 $\pi \longleftrightarrow -\emptyset / \text{ELSEWHERE}$   
 $\# \longleftrightarrow -\emptyset / [\text{SINGULAR}]$   
 $\# \longleftrightarrow -Iz / [\text{PARTICIPANT, PLURAL}]$   
 $\# \longleftrightarrow -lAr / [\text{PLURAL}]$

The disjunctive rule block in (79) captures all the agreeing morphemes in Turkish except for the idiosyncrasies of first person plurals. In Paradigm 1, first person plural is the single morpheme *-k* which does not share anything common with the first person singular *-m* or the plurals *-lAr* or *-Iz*. There are two ways to analyze *-k*. It can be analyzed as a fusion of  $\pi$  and  $\#$  heads, yielding [1, PL]. Alternatively, it could be argued that either the first person or plural is null while the other one is morphologically conditioned. I adopt the first proposal and claim that first person and plural morphemes fuse into a single morpheme by the rule in (79).

(80) Fuse  $\pi_{P1}$  and  $\#_{pl}$  into [1, PL]

The output of fusion in (80) is realized as *-k* by the following vocabulary insertion rule (which can be incorporated into the rule block in (79)).

(81) [1, PL]  $\longleftrightarrow -k$ 

The final idiosyncrasy is the realization of first person plural in Paradigm 2. First person plural in Paradigm 2 is realized as *-Iz* which is the plural portion of agreement with second plural as well as the morpheme that appears in first and second person pronouns *biz* ‘we’ and *siz* ‘you (pl)’. To keep the *Iz* portion consistent, I propose the following rule for first person in Paradigm 2.

(82) [1] $\pi_{P2} \longleftrightarrow -\emptyset / [+plural]$

The rules proposed above capture all the agreeing morphology in Turkish. So far, I have argued that in Turkish, there are two paradigms of agreement which correlate with the position of the agreement probes. In addition, I have argued that person and number probes in Turkish are essentially separate heads that fuse into a single morpheme only in certain contexts. The theory of agreement developed in this chapter aligns Turkish with Laz and predicts that agreement with an overtly case marked nominal should be possible even if no  $\varphi$ -features fuse with case. In regular transitive clauses, this is not possible to test because the verb always agrees with the subject, which is nominative. There are however some configurations that confirm the prediction. The two configurations are agreement with genitive marked nouns in nominalized clauses and agreement with accusative embedded subjects.<sup>24</sup> Let me start with the genitive subjects.

One of the strategies Turkish uses to embed one clause inside another one is nominalization. The main verb of the embedded clause bears a nominalizer/complementizer suffix. The nominalizer/complementizer can show up in the form of the suffix *-Dik*, *-mA*, or *-mAk*. *Dik* and *mA* are akin to finite embedded clauses as they allow overt subjects whereas *mAk* is more like an infinitival embedder as it disallows overt subjects and the subject of the embedded clause is controlled by the subject of the matrix clause. In the following, I focus on *Dik* nominalizations. The facts are similar in *mA* nominalizations while *mAk* nominalizations are irrelevant because they lack agreement – another aspect of their infinitival nature.

In *dik* nominalizations, *dik* attaches to the embedded verb. In addition, the nominalized verb bears agreement as well as a possessive morpheme, while the embedded subject receives a genitive morpheme that agrees with the person features of the subject. Number agreement is not visible in these cases because the realization of number agreement with singular subjects is null. Consider the following examples.

---

<sup>24</sup>Heartfelt thanks to Balkız Öztürk for bringing the Turkish data to my attention.

- (83) a. Ali gel-di.  
Ali come-PAST  
'Ali came.'
- b. Ben Ali-**nin** gel-**diğ-in-i** bil-iyor-um.  
1SG Ali-GEN.3 come-NMLZ-POSS.3-ACC know-PROG-1  
'I know that Ali came.'
- (84) a. Sen gel-di-n.  
2SG come-PAST-2  
'You came.'
- b. Ben sen-**in** gel-**diğ-in-i** bil-iyor-um.  
1SG 2SG-GEN.2 come-NMLZ-POSS.2-ACC know-PROG-1  
'I know that you came.'
- (85) a. Ben gel-di-m.  
1SG come-PAST-1  
'I came.'
- b. Sen ben-**im** gel-**diğ-im-i** bil-iyor-sun.  
2SG 1SG-GEN.1 come-NMLZ-POSS.1-ACC know-PROG-2  
'You know that I came.'

In (83) and (84), the person agreement morpheme on the embedded verbs look the same and could potentially indicate that second and third person agreement morphemes are one and the same. However, this is not true. The homophony of second and third person agreement morphemes on embedded verbs is accidental in these examples. Consider the following embedded clauses where the main verb is a coupla and the nominalized clause does not receive accusative case.

- (86) Ali-**nin** gel-diğ-i sır değil.  
Ali-GEN.3 come-NMLZ-POSS.3 secret not  
'It's not a secret that Ali came.'
- (87) Sen-**in** gel-diğ-in sır değil.  
2SG-GEN.2 come-NMLZ-POSS.2 secret not  
'It's not a secret that you came.'

The data in (83) through (87) show that, in Turkish, the embedded verb agrees with the genitive marked subject in person. In addition, the genitive morpheme on the subjects itself

agrees with the subject in person as well.<sup>25</sup> The prediction of the theory developed in this chapter is that the verb should be able to agree with the subject in number as well because number and person probe separately. This is also true in Turkish. Consider the following examples:

- (88) a. **Biz gel-di-k**  
 1 PL comePAST-1 PL  
 ‘We came.’
- b. **Biz-im gel-diğ-im-iz-i bil-iyor-lar**  
 1 PL-GEN.1 come-NMLZ-1-PL-ACC know-PROG-3PL  
 ‘They know that we came.’
- (89) a. **Siz gel-di-n-iz**  
 2 PL comePAST-2-PL  
 ‘Y’all came.’
- b. **Siz-in gel-diğ-in-iz-i bil-iyor-lar**  
 2 PL-GEN.2 come-NMLZ-2-PL-ACC know-PROG-3PL  
 ‘They know that y’all came.’

In the examples above, the plural feature of the subject does not fuse with the genitive. Nor is there number agreement on the genitive morpheme (unlike person agreement). Given that the person and number probes are separate in Turkish, the prediction is that number agreement with genitive marked subjects should go through. Since the number probe is looking for a number feature, it can look past the KP as well as  $\pi$ P, and agree with the number phrase below KP. As an illustration, the relevant structure of (88-a) is given below.<sup>26</sup>

<sup>25</sup>For a detailed description of genitive inducing nominalizations, see Aygen (2002).

<sup>26</sup>The person and number agreement examples in Turkish are examples of possessor agreement. When number and person probes are introduced separately, agreement with a genitive marked noun is possible. Jonathan Bobaljik (p.c.) suggests that this might predict that in ergative languages with possessor agreement, ergative subjects can be agreed with. Eskimo-Aleut languages are consistent with this prediction (Jonathan Bobaljik, p.c.). Among thirty three ergative languages on WALS, eighteen are reported to have possessor agreement. In six of these languages (Burushaski, Greenlandic (West), Shipibo-Konibo, Tukang Besi, Yup’ik (Central), Zoque (Copainal)), ergative subjects can be agreed with. In Trumai, ergative subjects do not seem to be agreed with. I do not have data on the other eleven languages (Coos (Hanis), Dani (Lower Grand Valley), Gooniyandi, Ika, Ingush, Kewa, Lezgian, Ngiyambaa, Paumar, Sanuma, Suena). My proposal predicts agreement with ergative subjects in languages with possessor agreement if the  $\varphi$ -features are separately introduced. I leave investigation of this prediction in these languages for future research.

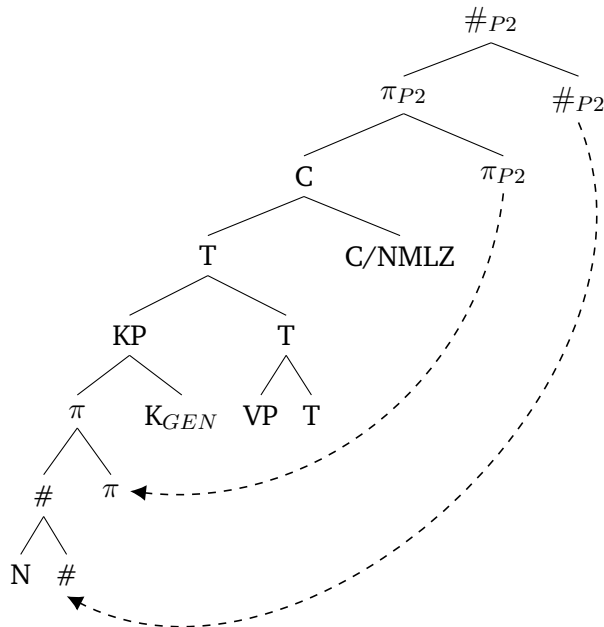

(90) *Relativized Probing in Turkish*

Whether the person probe on the embedded clause also looks past the KP structure is not clear though. It is hard to test whether the person probe agrees with the person feature on K (genitive) or looks past the K and finds the relevant person phrase. The answer depends mostly on the assumptions about whether a probe can agree with another probe or not. In the Chomskyan tradition (Chomsky 1995, 2000, 2001), a probe and a goal are defined through uninterpretable and interpretable features. Based on these definitions, the probe should agree with the person phrase but not the KP. An alternative to the interpretable/uninterpretable dichotomy was proposed by Pesetsky and Torrego (2007), who make a four way distinction with interpretable/uninterpretable and valued/unvalued features. In this model, it is possible for a probe (defined as an unvalued feature) to agree with another probe. Hence, the person probe should be able to agree with the genitive KP in person.

In Chapter 2, I defined a probe as a functional head with unvalued  $\varphi$ -features and a goal as a maximal projection with valued  $\varphi$ -features. Given that valuation (Agree-Copy) applies at PF and agreement relations (Agree-Link) must be established in the syntax, the theory predicts that a probe  $P_1$  cannot agree with another probe  $P_2$  since  $P_2$  is not valued by the

time Agree-Link applies, so it is not a goal by the definition of a goal provided in Chapter 2.

The second case in which an overtly case marked nominal is agreed with is the ECM-like configurations where the embedded subject gets accusative case while the embedded verb can agree with it in person and number. Consider the following examples.<sup>27</sup>

In ??, the subject of the embedded clause bears accusative case and it does not fuse with the pronoun, nor does it agree with it. However, full person and number agreement goes through. I take this fact to be a weak support for the theory that highly specified probes search past the irrelevant phrases including KPs. The reason why this is a weak support is that the facts are more complex than in ?? and it is not clear whether agreement with the embedded subject occurs before or after case assignment in these ECM constructions. As for the facts, there is a significant amount of variation in the agreement and case properties of ECM clauses like these. All of the following structures are grammatical with some variation in the degree of acceptability among native speakers.

(91) Ben siz gid-iyor-sun-uz san-di-m.  
 1SG 2PL go-PROG-2-PL suppose-PAST-1  
 'I thought you are/were going.'

(92) Ben siz-i gid-iyor san-di-m.  
 1SG 2PL-ACC go-PROG suppose-PAST-1  
 'I thought you are/were going.'

The data in (92) is particularly interesting as it is a case where the accusative subject is not agreed with, neither in person nor in number. This challenges the theory proposed here. One way to explain the variation without contradicting the theory proposed here is to suggest that the variation follows from the order of operations. If agreement happens after movement of the ECM subject, then (92) does not contradict the theory developed here. On the other hand, if agreement applies before case assignment in these constructions,

---

<sup>27</sup>The observation that accusative subjects can be agreed with was originally made by Kornfilt (1977). The following example is from Kornfilt's original observation.

(i) Pelin ben-i Timbuktu-ya git-ti-m san-iyor.  
 Pelin 1SG-ACC Timbuktu-DAT go-PAST-1 suppose-PROG  
 'Pelin believes that I went to Timbuktu.' (Kornfilt 1977)

then these constructions cannot be used as evidence to support the theory proposed here. The answers to these questions require a comprehensive analysis of ECM-like constructions in Turkish, which I do not attempt here.<sup>28</sup>

To sum up this section, I have argued that, in Turkish, number and person probes are separate heads and they probe separately. Based on these assumptions, Hypothesis II predicts that agreement should be case-insensitive. In other words, overt case should not block agreement. I have provided some evidence from embedded clauses where genitive marked subjects of embedded clauses can be agreed with person and number. I have also presented some possible support from accusative subjects of ECM clauses where the accusative marked subject can optionally be agreed with in person and number.

## 6 Beyond the Typology

In chapters 2 and 3, I explored a typology of agreement-case interactions and argued that the cross-linguistic variation in the interaction of agreement and case results from the variation in the lexical properties of probes (Hypothesis II) and the internal structures of goals (Hypothesis I). In particular, I have argued that in languages where agreement probes are relativized for specific  $\varphi$ -features like  $\pi$ ,  $\#$ ,  $\gamma$ , agreement is not sensitive to case marking. Since, the probes are relativized for specific features, they can skip over any irrelevant phrases and heads, including K. In contrast, in languages where agreement probes are underspecified and are specified for a generic feature like [+N], agreement is sensitive to case marking due to a Relativized Minimality type effect. KPs are extended nominal projections in Grimshaw's sense. Thus, they are the closest nominal phrase that an agreement probe can see. In such languages, only the features at the outermost layer of a nominal can be transferred. In some languages like Kurmanji, Icelandic, and Faroese, the number feature fuses with K making it possible to transfer the number feature but not the person feature. In other languages like Hindi, there is no fusion. Hence, no  $\varphi$ -feature can be transferred to a probe in that sort of language.

It should be noted that the theory presented in this chapter is about agreement only.

---

<sup>28</sup>For detailed analyses of ECM-like constructions in Turkish, see Şener (2008), Kornfilt (1977), Moore (1998), and Zidani-Eroğlu (1997) among others.

There are other ways of cross-referencing  $\varphi$ -features of a nominal on a verb/auxiliary. One such way is clitic doubling. Clitic doubling in many languages is CASE-INSENSITIVE. For example in Basque and Kichean, clitic doubling is insensitive to case-marking according to Preminger (2014). In fact, clitics copy/carry case information of the cross-referenced nominal while agreement doesn't. Phenomena like clitic doubling fall outside the typology entertained in this chapter. Case-sensitivity can be used as a weak test for clitic doubling vs. agreement. If a case marked nominal cannot be cross-referenced on a verb or if there is some disruption, this must be agreement. In contrast, if a case marked nominal can be cross-referenced on a verb despite case marking, this could be either clitic doubling or a corollary of relativized probing.

## 4

## DIFFERENTIAL OBJECT MARKING

The goal of this chapter is to investigate the of interaction of case-marking and agreement through the lens of Differential Object Marking (DOM). Focusing on differential object marking realized as overt case, I propose that there are at least two types of differential object marking. I use existing approaches to explain the first type and develop a novel system to account for the second type – one which extends the two-step Agree model developed in Chapter 2. The organization of this chapter is as follows: Section 1 provides a brief overview of the DOM literature and sketches a small typology by comparing DOM in Turkish, Hindi, and Kashmiri. Section 2 explores the details of DOM in Kashmiri. Section 3 discusses the key theoretical assumptions. Section 4 discusses the main proposal. Section 5 applies the proposal to the Kashmiri data. Section 6 provides an analysis of Hindi and Turkish. Section 7 extends the analysis to Senaya. Section 8 concludes the discussion.

### 1 Introduction

Differential object marking is a common phenomenon observed in a wide range of typologically unrelated languages, including Hindi (Indo-Aryan), Turkish (Turkic), Spanish (Romance), Hebrew (Semitic), Malayalam (Dravidian), etc. and it comes in a variety of forms including case-marking (Turkish, Hindi, Kashmiri), clitic doubling (Macedonian), agreement (Swahili, Senaya, Hungarian), use of a preposition (Italian dialects, Spanish), and

some others. Aissen (2003), citing Bossong (1985), highlights the presence of DOM in three hundred languages (as observed in 1985). The pervasiveness of DOM phenomena along with the amount of variation it exhibits makes it a theoretically appealing topic and it has interested many linguists including but not limited to Comrie (1979), Croft (1988) Bossong (1985, 1991), Bhatt and Anagnostopoulou (1996), Torrego (1998), de Hoop and Malchukov (2008), Aissen (2003), Næss (2004) Kalin (2018), Barány (2017), Baker (2015), Levin (2018), and van Urk (to appear).

Cross-linguistically, objects that get differential marking are associated with discourse related features like animacy, specificity, and definiteness. Aissen (2003) shows that an object is more likely to be differentially marked if it is on the higher end of what might be called discourse prominence hierarchies. The two hierarchies that are often discussed are the *Animacy Hierarchy* and the *Definiteness Hierarchy* which have been proposed by Silverstein (1976), Comrie (1979), and Croft (1988) among others, with slight differences. The two hierarchies make reference to some overlapping categories like pronoun and name.

(1) Animacy Hierarchy

1/2 > 3 Pronoun > Name > Human > Animate > Inanimate

(2) Definiteness Hierarchy

Pronoun > Name > Definite > Specific > Nonspecific

On the hierarchies given in (1) and (2), the categories on the left end of the scale are more likely to be overtly marked than the ones on the right. Languages also vary in terms of the cut-off points on the scale and whether they make reference to one of the hierarchies or both. For example, Turkish differentially marks all definite objects as well as indefinite specific objects ((3)) while in Hebrew DOM is restricted to definite objects (Aissen 2003). While indefinite specific objects are marked with accusative in Turkish ((3-c)), indefinite specific objects remain unmarked in Hebrew ((4-b)).

(3) *DOM in Turkish*

- a. Ayşe çocuğ-u gör-ecek.  
Ayşe kid-ACC see-FUT  
'Ayşe will see the kid.' (definite, specific)
- b. Ayşe bir çocuğ-u gör-ecek.  
Ayşe one kid-ACC see-FUT  
'Ayşe will see a certain kid.' (indefinite, specific)
- c. Ayşe bir çocuk gör-ecek.  
Ayşe one kid see-FUT  
'Ayşe will see a kid.' (indefinite, non-specific)

(4) *DOM in Hebrew*

(Aissen 2003, p. 453)

- a. Ha-seret her'a 'et-ha-milxama.  
DEF-movie showed ACC-DEF-war  
'The movie showed the war.' (definite)
- b. Ha-seret her'a (\*'et)-milxama.  
DEF-movie showed ACC-war  
'The movie showed a war.' (indefinite)
- c. Hu mexapes (\*'et) rofe 'exad.  
he is.looking (ACC-)doctor one  
'He's looking for a certain doctor.' (indefinite, specific)

The hierarchies in (1)-(2) are also implicational. Overt marking of a lower ranking element in these hierarchies implies the overt marking of higher ranking elements. For example in Turkish, specific nominals are overtly marked and so are all the elements ranking higher on the Specificity Hierarchy. The examples in (3-a) and (3-b) show that specific nouns and definite nouns get DOM while the examples in (5) show that higher ranking elements like proper nouns and pronouns also get DOM.

- (5) a. Ayşe Ali-yi gör-ecek.  
Ayşe Ali-ACC see-FUT  
'Ayşe will see Ali.' (proper noun)
- b. Ayşe on-u / sen-i / ben-i gör-ecek.  
Ayşe 3SG-ACC / 2SG-ACC / 1SG-ACC see-FUT  
'Ayşe will see her/him/it/you/me.' (pronoun)

In a nutshell, Differential Object Marking is a cover term for phenomena observed as the special marking of a subset of objects that are identified by some discourse related features like specificity/animacy. Languages vary in terms of what features play a role in differential marking and which hierarchy to use (or both).

Despite significant commonalities in DOM phenomena across languages, there are also significant differences that have made a uniform account of DOM difficult. This variation has contributed to a rich literature on differential object marking which can be categorized as i) differentiation based theories (Aissen 2003; de Hoop and Malchukov 2008), ii) feature based theories (Næss 2004), iii) movement based theories (Baker and Vinokurova 2010; Bhatt and Anagnostopoulou 1996), and iv) licensing based approaches (Barány 2017; Béjar and Rezac 2009; Kalin 2018; Levin 2018; van Urk to appear).

### 1.1 A Brief Overview of DOM Literature

In this section, I review some of the popular theories of Differential Object Marking based on i) feature identification, ii) Dependent Case, and iii) licensing.

One commonly held view regarding DOM is that the morpheme on a differentially marked object identifies a feature like specificity, animacy, definiteness, etc. Among the holders of this feature identification view are Enç (1991), Næss (2004), and de Hoop and Malchukov (2008). In this view, the differential object marking morpheme is considered to be the overt realization of certain features, like [+SPECIFIC] or [+DEFINITE]. Although common, analyses based on feature specifications suffer from a number of drawbacks. One drawback is that DOM is mostly restricted to objects but not other arguments. If DOM were just a matter of a feature specification (specific, definite, etc.), it would be fair to expect DOM on subjects as well. Another drawback is the fact that in some languages (like Kashmiri discussed in this chapter) feature specification on an object is a necessary but not sufficient condition for Differential Object Marking. For example in Kashmiri, a second person pronoun can receive DOM in some contexts but not others. This is a potential issue for almost all of the theories discussed in this section.



Another approach to differential object marking arises as a result of dependent case assignment (Baker and Vinokurova 2010; Baker 2015). In this model, one kind of differential object marking is considered to be the result of dependent case assignment (Marantz 1991) fed by movement. Specific objects move out of VP into the higher phase. This puts the subject and the object in the same domain and enables dependent case assignment. In languages where dependent case is assigned to the lower of the two arguments, the shifted object gets dependent accusative (or dative) case. When the object is non-specific, it remains inside the lower *v*P phase. Since the subject and the object are in different phases, they do not see each other and dependent case cannot be assigned.

A third recent line of research has treated DOM as a matter of licensing certain discourse related features like specificity, animacy, definiteness etc. Initially introduced by Béjar and Rezac (2009), licensing approaches have gained popularity through the works of Kalin (2018), Barány (2017), and Levin (2018). The main argument in this line of thought is that certain features need licensing via agreement. Differential Object Marking is the overt realization of this licensing relationship established between an agreement probe and a nominal that bears a certain feature.

In this chapter, I propose a novel theory of Differential Object Marking within the licensing framework. I also argue that Differential Object Marking is not a uniform phenomenon and different forms of DOM should be treated by different theories. More specifically, I argue that in some languages like Hindi and Turkish, DOM is the result of Dependent Case assignment that can bleed overt agreement, while in some other languages like Kashmiri, DOM is the result of Agree-Case, a post-syntactic case assignment operation that resolves Agree-Link relations by marking the goal rather than the probe. In the next section, I discuss some properties of DOM from Hindi, Turkish and Kashmiri to show that DOM is not a unified phenomenon and show that different accounts are needed.

## 1.2 DOM in Three Sample Languages

In this section, I compare properties of Differential Object Marking from three different languages, Turkish, Hindi, and Kashmiri, where DOM is realized as overt case on a proper subset of objects. The goal of this section is not to provide a full-fledged analysis of differential object marking in these languages. Instead, the main goal is to show that what is called differential object marking in these languages are realizations of different morpho-syntactic processes. This section will set the stage for the next section, which discusses the details of differential object marking in Kashmiri and provide some motivation for a novel account of differential object marking for Kashmiri-like languages.

Differential Object Marking is realized as overt case in Turkish, Hindi, and Kashmiri. While in Turkish, DOM is triggered by specificity, in Hindi and Kashmiri, it is sensitive to animacy and specificity.<sup>1</sup>

- (6) Ayşe defter-**i** al-acak.  
Ayşe notebook-ACC buy-FUT  
'Ayşe will buy the notebook.' Turkish
- (7) Siita-ne larkii-**ko** dekhaa.  
Sita.FEM-ERG girl.FEM-ACC see.PERF.MASC  
'Sita saw the girl.' Hindi (Bobaljik 2008)
- (8) az vuchan daaktar mariiz-**as** waarpaathyii.  
today see.FUT.3PL doctors patient-DAT carefully  
'Today, the doctors will examine the patient carefully.' Kashmiri (Bhatt 2013)

In Turkish and Kashmiri, differential marking is lost in passivization. When the internal argument ends up being the subject in passive clauses, it loses the DOM case (ACC in Turkish and DAT in Kashmiri) and shows up as unmarked (nominative/absolutive).

- (9) Defter al-**ın**-acak.  
notebook buy-PASS-FUT  
'The notebook will be bought.' Turkish

<sup>1</sup>In the next section, we will see that the facts in Kashmiri are a bit more complicated.

- (10) a. su kariy tse me hava:li.  
3SG.Ø do-FUT-2SG 2SG.DAT 1SG.DAT handover  
'He will hand you over to me.'
- b. tsi yikh me hava:li karni tamsindi dəs'.  
2SG.Ø come.FUT-2SG.PASS 1SG.DAT handover do.INF.ABL 3SG.GEN by  
'You will be handed over to me by him.' Kashmiri (Wali and Koul 1997,  
p. 208)

The passivization test suggests that the DOM cases in Turkish and Kashmiri are structural but not inherent.<sup>2</sup> The facts are a bit more complex in Hindi. The internal argument can retain the DOM marker *-ko* under passivization as in (11-b) but does not have to, as shown in (11-c).

- (11) a. Raam-ne Rina-ko/\*Rina baazaar-mẽ dekh-aa thaa.  
Ram-ERG Rina-KO/Rina market-in see-PFV.DEFAULT be-PST.DEFAULT  
'Ram had seen Rina in the market.'
- b. Rina-ko baazaar-mẽ dekh-aa gayaa thaa.  
Rina-KO market-in see-PFV.DEFAULT PASS.PFV.DEFAULT be-PST.DEFAULT  
'Rina had been seen in the market.'
- c. Rina baazaar-mẽ dekh-ii gayii thii.  
Rina market-in see-PFV.F PASS.PFV.F be-PST.F  
'Rina had been seen in the market.' (Bhatt 2007a)

Bhatt (2007a) analyzes the difference between (11-b) and (11-c) as a matter of promotion to subject position. He argues that the object is not promoted to the subject position in (11-b) while it is in (11-c). In addition, he shows that the presence of a finite T also plays a role on the presence of *ko* on the internal argument in passive clauses. When the clause is infinitive, there is no agreement between the verb and the *ko* marked internal argument and *ko* has to be retained.

- (12) a. Rina-ko bazaar-mẽ dekh-aa jaa-naa sharam-kii baat hai.  
RinaKO market-in see-PFV PASS-INF shame-GEN.F thing.F is  
'For Rina to be seen in the market is a matter of shame.'

<sup>2</sup>The observation that DOM case in Kashmiri is structural belongs to Béjar and Rezac (2009). See also Barány (2017).

- b. \*Rina bazaar-mē dekh-aa jaa-naa sharam-kii baat hai.  
 Rina market-in see-PFV PASS-INF shame-GEN.F thing.F is  
 ‘For Rina to be seen in the market is a matter of shame.’ (Bhatt 2007a)

Baker (forthcoming) analyzes *ko* as Dependent accusative case and attributes the variability of the *ko* marking on the theme argument in passive clauses to the final landing site of the theme argument. He claims that theme arguments moved above the null external argument remain unmarked whereas theme arguments that land under the null external argument receive dependent accusative case. See Baker (forthcoming) for further details. Following Baker (forthcoming) and Bhatt (2007a), I assume *ko* to be structurally assigned case. With this assumption in place, Hindi, Turkish, and Kashmiri are aligned together in that DOM case is structural in all three languages. This eliminates the possibility of inherent case analyses for DOM in these languages.

The second dimension along which I compare Hindi, Turkish, and Kashmiri is the availability of asymmetric DOM. In a recent paper Kalin and Weisser (2017) show that in many languages, a differentially marked nominal can be coordinated with an unmarked nominal. For example, in Spanish specific animate objects are marked with the preposition *a*. When an animate specific object is conjoined with an animate non-specific noun, only the specific one gets DOM.

- (13) Vi una mujer y a María junt-as en el parque.  
 see.PAST.1SG a woman and DAT Maria together-FEM.PL in the park  
 ‘I saw a (some) woman and Maria together in the park.’ Spanish (Kalin and Weisser 2017)

Weisser (2017) argues that non DOM case is always distributed symmetrically on each conjunct in a conjunction. DOM case on the other hand can be distributed asymmetrically among conjuncts. Kalin and Weisser (2017) show that in a wide range of languages, asymmetric DOM like in (13) is allowed. This indicates a fundamental difference between how non-DOM case is assigned as opposed to DOM case (Kalin and Weisser 2017; Weisser 2017). In the following, I show that Kashmiri behaves differently compared to Turkish and Hindi in with respect to asymmetric DOM. While Kashmiri marginally allows asymmetric DOM,

Turkish and Hindi disallow it.

Let us start with Turkish. In Turkish, an object gets DOM if it is specific.

- (14) a. Ali bir çocuk gördü.  
Ali a child see-PAST  
'Ali saw a child.' *Indefinite non-specific*
- b. Ali çocuğ-u gördü.  
Ali child-ACC see-PAST  
'Ali saw the child.' *Definite specific*

Two non-specific objects can be coordinated as in (15-a). Similarly, two specific objects can be coordinated as in (15-b).

- (15) a. Ali (bir) ev ve (bir) araba al-acak.  
Ali a house and a car buy-FUT  
'Ali will buy a house and a car.' *non-specific – non-specific*
- b. Ali ev-i ve araba-yı al-acak.  
Ali house-ACC and car-ACC buy-FUT  
'Ali will buy the house and the car.' *definite, specific – definite, specific*

Coordination of a specific object and a non-specific object is not grammatical in Turkish. In (16), the first conjunct is marked with DOM case while the object is in its bare form and this is ungrammatical.

- (16) a. \*Ali adam-ı ve bir çocuk gör-dü.  
Ali man-ACC and a child see-PAST  
'Ali saw the man and a (non-specific) kid.'
- b. \*Ali adam-ı ve çocuk gör-dü.  
Ali man-ACC and child see-PAST  
'Ali saw the man and (non-specific) kid.'

It should be noted that it is possible to get the DOM marker on only one of the conjuncts when it is on the second conjunct as in (17). However, Turkish is a head-final language and the DOM marker presumably attaches to the entire conjunction phrase in such examples. This is supported by the fact that both of the conjuncts are interpreted as definite and specific. In particular, the first conjunct in (17) cannot be interpreted as non-specific.

- (17) Ali ev ve araba-yı al-dı.  
 Ali house and car-ACC buy-PAST  
 'Ali bought the house and the car.'

The final note about the differential object marking in Turkish is that the DOM marked nominals precede low adverbs while unmarked nominals cannot. This is shown in (18) and (19).<sup>3</sup>

- (18) a. Ali sessizce kitap oku-du.  
 Ali quietly book read-PAST  
 'Ali quietly read (a) book.'
- b. \*Ali kitap sessizce okudu.  
 Ali book quietly read-PAST  
 'Ali quietly read (a) book.'

- (19) Ali kitab-ı sessizce okudu.  
 Ali book quietly read-PAST  
 'Ali quietly read the book.'

The positioning of the internal argument with respect to a low adverb works the same when two objects are coordinated. The DOM marked objects precede the low adverb while the unmarked nominals cannot.

- (20) a. Ali masa-ya yavaşça çay ve kahve koy-du.  
 Ali table-DAT slowly tea and coffee put-PAST  
 'Ali slowly put (some) coffee and tea on the table.' *non-specific*
- b. \*Ali masa-ya çay ve kahve yavaşça koy-du.  
 Ali table-DAT tea and coffee slowly put-PAST  
 'Ali slowly put (some) coffee and tea on the table.' *non-specific*

---

<sup>3</sup> The DOM marked object can follow the adverb *sessizce* "quietly" in some cases.

- (i) Ali sessizce kitab-ı oku-du.  
 Ali quietly book read-PAST  
 'Ali quietly read (a) book.'

The sentence above has two interpretations both different from the one in (19). One felicitous interpretation is that the object is in contrastive focus as in "He read the BOOK quietly (not the magazine)." The second interpretation is more about the overall manner in which the subject was acting. The adverb modifies the subject's manners. In the sentence above, the adverb is placed higher than the position where the internal argument can move to.

- (21) Ali masa-ya çay-ı ve kahve-yi yavaşça koy-du.  
 Ali table-DAT tea-ACC and coffee-ACC slowly put-PAST  
 'Ali put the tea and the coffee on the table slowly.'

To sum up the DOM facts in Turkish, DOM marked objects precede low adverbs while unmarked objects cannot. In addition, when two objects are coordinated, if the conjunct on the left gets DOM, the one on the right must also get DOM marking. In other words, DOM in Turkish is symmetric.

Next, let us consider Hindi. In Hindi, a proper subset of direct objects are marked with the morpheme *-ko* (Bhatt and Anagnostopoulou 1996; Mahajan 1990b). First and second person pronoun objects as well as animate proper nouns must receive *-ko* (Bhatt 2007a).

- (22) Mina tum-\*(ko) / Tina-\*(ko) dekh rahii thii.  
 Mina.F 2SG-KO / Tina-KO see PROG.F BE.PST.F.SG  
 'Mona was looking at you/Tina.' Bhatt (2007a)

Third person pronoun objects receive *-ko* when they are animate (Bhatt 2007a).

- (23) Mina us-ko / vo uṭhaa rahii thii.  
 Mina.F 3-KO / 3 lift PROG.F BE.PST.F.SG  
 'Mona is lifting it/him/her (with ko); lifting it/\*him/\*her (without ko).' (Bhatt 2007a)

When the object is a common noun, *-ko* adds specificity.

- (24) a. Mina ek bacca uṭhaa rahii thii.  
 Mina.F a/one child lift PROG.F BE.PST.F.SG  
 'Mina is lifting a child.' (Bhatt 2007a)
- b. Mina ek bacce-ko uṭhaa rahii thii.  
 Mina.F a/one child-KO lift PROG.F BE.PST.F.SG  
 'Mina is lifting a child.' (a particular child) (Bhatt 2007a)
- (25) a. Mina haar uṭhaa rahii thii.  
 Mina.F necklace lift PROG.F BE.PST.F.SG  
 'Mina is lifting a necklace.' (Bhatt 2007a)

- b. Mina haar-ko uṭḥaa rahii thii.  
 Mina.F necklace-KO lift PROG.F BE.PST.F.SG  
 ‘Mina is lifting the necklace.’ (Bhatt 2007a)

Finally, *-ko* is banned on non-referential NPs.

- (26) Mina ungalii-tak-(\*ko) nahī: uṭḥaa-egii.  
 Mina.F finger.F-EVEN-KO NEG lift-FUT.3SG  
 ‘Mina won’t even lift a finger.’ (Bhatt 2007a)

Like in Turkish, DOM marked nominals appear in positions that unmarked nominals cannot. Bhatt and Anagnostopoulou (1996) argue that *-ko* marked nominals move out of the VP. Their proposed structure for a clause with DOM marked object is as in (27).

- (27) Ram-ne Aditya-ko<sub>i</sub> [<sub>VP</sub> t<sub>i</sub> dekh-aa ].  
 Ram.ERG Aditya-KO see-PFV  
 ‘Ram saw Aditya.’ (Bhatt and Anagnostopoulou 1996)

Bhatt and Anagnostopoulou (1996) report that the adverb placement test is not reliable because adverbs do not seem to have a fixed position in Hindi. Instead, they support the movement hypothesis with object shift in double object constructions in Hindi. Whereas an unmarked direct object follows the indirect object, a *-ko* marked direct object appears before the indirect object. Bhatt and Anagnostopoulou (1996) report that the object shift is obligatory when the object is *ko*-marked.

- (28) Ram-ne Anita-ko chitthii bhej-ii.  
 Ram-ERG Anita-KO letter.F send-PFV.F  
 ‘Ram sent the letter to Anita.’ (Bhatt and Anagnostopoulou 1996)

- (29) Ram-ne chitthii-ko Anita-ko bhej-aa.  
 Ram-ERG letter.F-KO Anita-KO send-PFV  
 ‘Ram sent the letter to Anita.’ (Bhatt and Anagnostopoulou 1996)

Like Turkish, Hindi disallows coordination of a *ko*-marked object and an unmarked object (Kalin and Weisser 2017).



- (30) ???/\* Vo shikaari [<sub>VP</sub> sher-KO or hiran ] maar degaa.  
 that hunter tiger-KO and deer kill give.FUT.3SG  
 ‘The hunter will kill the tiger and a deer.’ (Kalin and Weisser 2017)

To sum up, Hindi is like Turkish in that overtly marked objects appear in a different position than the unmarked objects. In addition, neither language allows asymmetric DOM. In other words, if the conjunct on the left is marked differentially, then the one on the right must also be marked overtly. Alternatively, the entire conjunction phrase can be marked overtly as a single unit.

Finally, let me turn to Kashmiri. I discuss the details of differential object marking in Kashmiri in the next section. I briefly mention the asymmetric DOM facts in Kashmiri here. Unlike Hindi and Turkish, Kashmiri marginally allows asymmetric DOM.<sup>4</sup>

- (31) ?tsi ch-u=kh **yi** ti **me** tul-a:n.  
 you.Ø be.M.SG=2SG 3SG.Ø and 1SG.DAT lift-PTCP.PRES  
 ‘You are lifting him and me.’

- (32) ?tsi ch-u=kh **me** ti **yi** tul-a:n.  
 you.Ø be.M.SG=2SG 1SG.DAT and 3SG.Ø PTCP.PRES  
 ‘You are lifting me and him.’

The data in (31) and (32) show that Kashmiri marginally allows asymmetric coordination of a DOM marked object and an unmarked object. It is worth noting that both of the objects are specific and animate in the Kashmiri clauses above, yet only one of the objects receives DOM. In Kashmiri, unlike in Turkish and Hindi, whether an object receives DOM depends on the features of the subject as well. This is discussed in detail in the next section.

A second difference between Turkish and Hindi versus Kashmiri is the fact that DOM is omnipresent across tenses and aspects in Hindi and Turkish while it is restricted to certain aspects in Kashmiri. Let us start with Turkish. In Turkish DOM occurs across all the tenses

<sup>4</sup>My consultant’s judgments varied on different occasions. I tried eliciting asymmetric DOM examples in three different sessions. In the first session, he found asymmetric DOM examples ungrammatical. In the following two sessions (with some days in between) he found asymmetric DOM examples acceptable. Overall, he preferred symmetric DOM better than asymmetric DOM but accepted both. Andras Barany (p.c.) reports that his consultant does not accept asymmetric coordination cases. It seems that there is variation across and within speakers with respect to asymmetric coordination. Mark Baker (p.c.) reports similar variation effects among Hindi speakers.

and aspects including infinitival clauses.

- (33) a. Mine Mehmet-i gör-üyor.  
 Mine Mehmet-ACC see-PROG.PRES  
 ‘Mine sees Mehmet.’ *Present Imperfective*
- b. Mine Mehmet-i gör-üyor-du.  
 Mine Mehmet-ACC see-PROG.PRES-PAST  
 ‘Mine was seeing Mehmet.’ *Past Imperfective*
- c. Mine Mehmet-i gör-dü.  
 Mine Mehmet-ACC see-PAST  
 ‘Mine saw Mehmet.’ *Past Perfective*
- d. Mine Mehmet-i gör-ecek.  
 Mine Mehmet-ACC see-FUT  
 ‘Mine will see Mehmet.’ *Future*
- e. Mine Mehmet-i gör-mek isti-yor.  
 Mine Mehmet-ACC see-INF want-PROG.PRES  
 ‘Mine wants to see Mehmet.’ *Infinitival*

Hindi is like Turkish in that DOM occurs across different tenses and aspects. For example in (34) tense is past and the aspect is imperfective. The object is animate and specific and receives DOM case.

- (34) Mina tum-\*(ko) / Tina-\*(ko) dekh rahii thii.  
 Mina.F 2SG-KO / Tina-KO see PROG.F BE.PST.F.SG  
 ‘Mona was looking at you/Tina.’ (Bhatt 2007a)

In (35), the aspect is perfective and the specific animate object receives differential object marking.

- (35) Ram-ne Aditya-ko dekh-aa .  
 Ram.ERG Aditya-KO see-PFV  
 ‘Ram saw Aditya.’ (Bhatt and Anagnostopoulou 1996)

One crucial fact about Hindi to bear in mind is that it is a split ergative language. The alignment in imperfective clauses is accusative while the alignment in perfective clauses is ergative. In (34) the subject is unmarked (absolute) whereas in (35) the subject receives ergative case. Differential Object Marking occurs independently of split ergativity in Hindi.



that DOM in Turkish and Hindi is the realization of Dependent Case assigned in the syntax while DOM in Kashmiri is the realization of Agree-Case, a post-syntactic case assignment mechanism. In the next section, I discuss the details of DOM in Kashmiri.

## 2 DOM in Kashmiri

Differential Object Marking in Kashmiri has some significant properties that are not very common. As in many languages, DOM is sensitive to animacy and specificity. Yet, DOM in Kashmiri is also sensitive to aspect. In non-perfective clauses, specific animate nouns receive dative case while inanimate or non-specific nouns remain caseless.

(39) az vuchan daaktar **mariiz-as** waarpaathyii.  
 today see.FUT.3PL doctors patient-DAT carefully  
 ‘Today, the doctors will examine the patient carefully. (Bhatt 2013, p. 176)

(40) az vuchan daaktar waarpaathyii **mariiz**.  
 today see.FUT.3PL doctors carefully patient  
 ‘Today, the doctors will examine a patient carefully. (Bhatt 2013, p. 177)

In (39), the object is specific and animate. It appears on the left side of the low adverb *waarpaathyii* ‘carefully’ and receives dative case. In contrast, the object in (40) remains caseless and appears on the right side of the same adverb. The interpretation is non-specific. It should be noted that Kashmiri is a verb second language and the verb moves to the second place in the absence of an auxiliary. The data in (39)-(40) shows that specific objects in Kashmiri move above low adverbs like ‘carefully’ while non-specific ones remain in situ. Non-specific nouns cannot precede low adverbs as shown in (41). Similarly, dative-marked specific objects cannot follow low adverbs as in (42).

(41) ???az vuchan daaktar **mariiz** waarpaathyii.  
 today see.FUT.3PL doctors patient carefully  
 ‘Today, the doctors will examine a patient carefully. (Bhatt 2013, p. 177)

(42) ???az vuchan daaktar waarpaathyii **mariiz-as**.  
 today see.FUT.3PL doctors carefully patient-DAT  
 ‘Today, the doctors will examine the patient carefully. (Bhatt 2013, p. 176)

Besides specificity, animacy is a requirement for Differential Object Marking in Kashmiri. Inanimate objects do not get differential dative case when specific. This is shown in (43).<sup>5</sup> This contrasts with animate nouns which get differential dative case when specific ((44), (39)).

(43) hu ch-u            **p'a:li** tul-a:n.  
3SG be.PRES-M.SG cup lift-PTCP.PRES  
'He is lifting the cup.'

(44) hu ch-u            **lɔdk-as** tul-a:n.  
3SG be.PRES-M.SG boy-DAT lift-PTCP.PRES  
'He is lifting the boy.'

While specific animate nouns receive differential dative case in non-perfective clauses, Differential Object Marking does not occur in perfective clauses. In perfective clauses, transitive subjects (as well as some unergative subjects) receive ergative case while the objects remain caseless. In such clauses, the verb agrees with the object in number and gender but not with the ergative subject. Consider the following example.

(45) timav vuch        **mohni** ə:nas manz.  
3PL.ERG saw.M.SG mohan mirror in  
'They saw Mohan in the mirror.'        (adapted from Wali and Koul 1997, p. 130)

In (45), the verb agrees with the object in gender and number. The object, despite being animate and specific, does not receive differential dative case. This contrasts with an imperfective clause where a proper noun gets dative case in the object position. This is shown

<sup>5</sup>There are contexts where inanimate nouns get dative case. Bhatt (2013) argues that dative case on objects is not related to animacy by presenting an inanimate object in dative case in an imperative clause.

(i) yath kurs-yi lam.  
this.DAT chair-DAT pull  
'Pull this chair.'

In a casual conversation, my consultant used an inanimate specific object in dative case when the subject was also inanimate. The example was 'The stone is smashing the window.' I did not have a chance to confirm the data by controlling the necessary variables. For example, some verbs in Kashmiri assign inherent dative case to their internal arguments. Unfortunately, I do not have access to the facts. Further data elicitation is needed to confirm the interaction of animacy and DOM in Kashmiri. For now, I assume that inanimate nouns do not get DOM.



- (48) Raam-ne Anita-ko chitthii bhej-ii.  
 Ram-ERG Anita-KO letter.F send-PERF.F  
 ‘Ram sent a letter to Anita.’ (Bhatt and Anagnostopoulou 1996)
- (49) Raam-ne chitthii-**ko** Anita-ko bhej-aa.  
 Ram-ERG letter.F-KO Anita-KO send-PERF.M  
 ‘Ram sent the letter to Anita.’ (Bhatt and Anagnostopoulou 1996)
- (50) Mina us-**ko** uthaa rahii hai.  
 Mina.F 3SG-KO lift PROG.F be.PRES.3SG  
 ‘Mina is lifting it/him/her.’ (Bhatt 2007b, p. 2)

The second distinctive property of Differential Object Marking in Kashmiri is that it is further restricted by Person Hierarchy effects. In addition to the animacy and specificity of the object, the properties of the subject also play a role in Kashmiri DOM. In (44), the object is [ANIMATE, SPECIFIC] and receives dative case. However, the same object remains unmarked when the subject is a first or second person pronoun as in (51).

- (51) bi ch-u=s ləɖki tul-a:n.  
 1SG.Ø be.PRES-M.SG=1SG boy.Ø lift-PTCP.PRES  
 ‘I am lifting the boy.’

Similar facts obtain for pronouns as well. For example, a second person pronoun gets differential object marking when the subject is a third person pronoun or a non-pronominal NP but remains unmarked when the subject is a first person pronoun.

- (52) **hu** ch-u tse / \*tʃi tul-a:n.  
 he.Ø be.PRES-M.SG you.DAT / you.Ø lift-PTCP.PRES  
 ‘He is lifting you.’
- (53) **bi** ch-u=s tʃi / \*tse tul-a:n.  
 I.Ø be.PRES-M.SG=1SG you.Ø / you.DAT lift-PTCP.PRES  
 ‘I am lifting you.’

In (52), the subject is third person and the second person object receives dative whereas in (53), the subject is first person and the same object is unmarked this time. When the subject is higher than the object on the person hierarchy in (54), the object remains caseless. In

contrast, when the object is higher than the subject, the object gets dative case.

(54) Person Hierarchy

1 > 2 > 3

Differential Object Marking also occurs in cases when the subject and the object are both third person pronouns as in (55).

(55) su vuch-i temis / \*su.  
3SG.Ø see-FUT 3SG.DAT / 3SG.Ø  
'He will see him.'

(Wali and Koul 1997)

The table in (56) shows the case marking on the object in all the possible combinations of pronouns. (See Barány (2017) for the same observation.)

(56)	S\O	1	2	3
	1	—	∅	∅
	2	DAT	—	∅
	3	DAT	DAT	DAT

One thing that has not been paid much attention in Kashmiri Differential Object Marking is the interaction between pronouns and non-pronominal NPs. In (57) and (58), we observe that specific animate non-pronominal objects behave like third person pronouns. They are caseless when the subject is first or second person but they are dative when the subject is a third person or a non-pronominal NP.

(57) hu ch-u lədk-as tul-a:n.  
3SG be.PRES-M.SG boy-DAT lift-PTCP.PRES  
'He is lifting the boy.'

(58) bi ch-u=s lədk-i tul-a:n.  
1SG.Ø be.PRES-M.SG=1SG boy.Ø lift-PTCP.PRES  
'I am lifting the boy.'

Based on these facts, one could argue that non-pronominal NPs are treated as third person



pronouns and all the Differential Object Marking patterns can be tied to the person hierarchy in (55) without any reference to specificity or animacy. Yet, this would miss the facts presented by (59)-(60). Inanimate objects do not behave like third person pronouns. They are never dative no matter what the subject is (at least if the subject is animate; see 5 for a possible exception.)

(59) hu ch-u p'a:li tul-a:n.  
 3SG.Ø be.PRES-M.SG cup.Ø lift-PTCP.PRES  
 'He is lifting the cup.'

(60) bi ch-u=s p'a:li tul-a:n.  
 1SG.Ø be.PRES-M.SG=1SG cup.Ø lift-PTCP.PRES  
 'I am lifting the cup.'

The fact that inanimate NPs do not interact with other pronouns like animate nouns or third pronouns indicates that Differential Object Marking in Kashmiri is not only regulated by a three way distinction among pronouns as indicated by the person hierarchy in (55). In fact, there is a four way distinction based on animacy and the pronominal features. This can be captured by the extended Kashmiri Animacy Hierarchy in (61).

(61) Kashmiri Animacy Hierarchy (KAH)  
 $1 > 2 > \textit{Animate} > \textit{Inanimate}$  ' > ' means 'higher than'.

The hierarchy in (61) makes reference to a subset of the features in the animacy hierarchy proposed by Silverstein (1976) given in (1). The Kashmiri Animacy Hierarchy can provide a larger and a more precise generalization capturing the differential object marking in Kashmiri. The generalization is provided in (62).

(62) If NP1 c-commands NP2,  
 if NP2 is animate and  $NP2 \geq NP1$  on the KAH,  
 then NP2 is DATIVE.

The generalization in (62) is still incomplete to capture the DOM facts in Kashmiri as it does

not make any reference to specificity. Without any reference to specificity, (62) predicts the animate object in (40) to be marked dative, which is not true. Below, I argue that specificity does not have a place on the Kashmiri Animacy Hierarchy. Instead, its contribution is restricted to moving the object outside the VP (in line with the proposals of Diesing (1992), Bhatt and Anagnostopoulou (1996), and Torrego (1998) and supported by (39)). This provides the necessary conditions for assigning Differential Object Marking.

To sum up the facts, Differential Object Marking does not occur in perfective clauses where the subject is ergative and the verb agrees with the object. Differential Object Marking occurs only in imperfective clauses and it is regulated by an animacy hierarchy. Specific animate objects that are c-commanded by a nominal that is at the same level as the object or lower on the animacy hierarchy get differential object marking. Otherwise, they remain caseless.

A theory of Differential Object Marking then should be able to capture both the aspect dependency of DOM in Kashmiri as well as the animacy hierarchy effects. In the following, I provide a novel analysis of DOM based on the two-step Agree model developed in the previous chapters. This novel account captures the aspect dependence as well as the animacy hierarchy effects.

### **3 Theoretical Assumptions**

In this section, I discuss the assumptions that the proposal rests on regarding case and licensing.

#### **3.1 Case**

One dominant view on case in the literature has been the agreement-centric view of Chomsky (2000, 2001), with earlier roots from the GB era (Chomsky 1981). In this model, structural case is assigned to a noun phrase as a result of agreement between a head *F* and the noun phrase. Structural case assigned via Agree satisfies an abstract requirement on the expression of nominals, the Case Filter (first raised by Vergnaud in a 1977 letter, later published as Vergnaud (2008)). This model is based on the assumption that all nominals

must be licensed through abstract case assignment.

Another view that has been gaining significant traction is Marantz's (1991) morphological case model. In this view, abstract case does not exist; hence, there is no abstract licensing requirement on nominals (no Case Filter). Case is purely morphological and is realized by morphological rules disjunctively ordered as in (63).

- (63) *Case Realization Disjunctive Hierarchy* Marantz (1991, p. 24)
- a. Lexically governed case
  - b. Dependent case
  - c. Unmarked case (environment sensitive)
  - d. Default case

In this model, lexically governed case takes precedence over everything else. Inherent case and quirky case can be considered as varieties of lexically governed case. There is not much debate over the existence of lexically governed case. This is even acknowledged in Chomsky's original case theory.

There has been a growing literature on dependent case (Baker and Vinokurova 2010; Baker 2015; Bobaljik 2008; Levin and Preminger 2015). Dependent case is the case assigned to one of the two arguments in a case domain based on c-command relations between the two nominals. Dependent case theory has been quite successful, especially in accounting for ergative languages.

Two of the less discussed and probably less clear elements of the Marantzian case system are Unmarked Case ((63-c)) and Default Case ((63-d)). For Marantz (1991), Unmarked Case does not necessarily mean morphologically zero-marked. Unmarked Case is sensitive to the syntactic environment. Citing Marantz's example, unmarked case in the DP can be genitive whereas the unmarked case in the TP may be nominative. Default case, on the other hand, is the *elsewhere* case that is assigned when no other case realization principle is applicable. For the purposes of this dissertation, Default Case and Unmarked Case are not especially relevant. I do not make any claims about their nature or the order in which they apply.

Both Chomsky and Marantz postulate some version of lexically assigned case. Leaving unmarked and default cases aside, the main difference between the Chomskyan and the Marantzian case mechanisms boil down to the difference between Agree-assigned Case and Dependent Case. In the Chomskyan view, Agree assigns case to a nominal upon agreement with the nominal. In contrast, in the Dependent Case view, case is dissociated from Agree and is assigned based on c-command relations between two NPs that are in the same case domain.

A growing body of literature has been challenging the Agree-assigned case view and providing support for the Dependent Case view. One of the early challenges for the Agree assigned case view was presented by Bhatt (2005). Bhatt showed that in Hindi T can agree with objects that it does not assign case. Bobaljik (2008) showed that a framework where agreement is dissociated from case assignment and case assignment precedes agreement accounts for the lack of agreement with overtly case marked nominals in a wide variety of languages. Baker (2015) has shown that the dependent case view accounts for ergative, split ergative, and tripartite languages successfully. The Agree-assigned view is particularly problematic with split-ergative languages. This is why I adopted the dependent case view for Kurmanji, too (see Chapter 2, Section 4.3). Levin and Preminger (2015) have argued that the agreement-centric case assignment is unnecessary as the dependent case theory can, in fact, account for the facts accounted by the agreement-centric view (in Sakha specifically).

Following the literature dissociating agreement from case assignment, I adopt the view that the syntactic operation Agree does not assign case because the Agree-assigned case view faces the serious challenges as discussed above. The fact that overt case blocks agreement in many languages indicates that Agree does not assign case. Instead, it follows (some) case assignment and feeds off of the already case-marked nominals. Another main issue is Multiple Agree. Cases of a Multiple Agree relation between a single probe and two separate goals with different cases is another challenge for the Agree assigned case view.

Although I do not adopt the Chomskyan Agree-assigned case view, I argue that Agree still plays a role in a particular kind of case assignment. In the previous section, I have

shown that the differential case in Kashmiri behaves differently from the differential case in Turkish and Kurmanji. In all these languages, the DOM case is structural, not Inherent Case. The main contender for the DOM case is Dependent Case. Dependent Case by itself cannot suffice to account for all the three languages given the significant differences between DOM in Kashmiri and the two other languages. In Section 6, I show how Dependent Case accounts for DOM in Hindi and Turkish. Here, I briefly discuss why Dependent Case cannot account for DOM in Kashmiri.

The animacy hierarchy effects in Kashmiri make a Dependent Case analysis difficult. The fact that a second person pronoun can get DOM when the subject is third person but not when the subject is first person cannot be captured by Dependent Case straightforwardly.

Given that the main contender for DOM case cannot account for the Kashmiri facts, we need an alternative case operation. In the next few sections, I show that the DOM in Kashmiri is a result of the licensing requirements on marked nominals, where licensing is established via Agree-Link. Animate nouns need licensing in certain well defined configurations. This licensing occurs through an Agree-Link relation between a probe and the animate noun. An Agree-Link relation can be transduced into overt agreement by Agree-Copy. However, in certain cases an Agree-Link relation can also be transduced into overt case when Agree-Copy cannot apply. I call the operation that transduces an Agree-Link relation into case Agree-Case.

(64) **Agree-Case**

Agree-Case takes as input a substructure of the form  $P_{[\rightarrow G]}$  and returns  $G_{case}$  by replacing the pointer from P to G with case on G.

Agree-Case is reminiscent of Dependent Marking of Nichols (1986), who argues that morphological marking of grammatical relations may appear on either the head (Head-marking) or on the dependent (Dependent-marking). Agree-Link is the operation that establishes grammatical relations. Agree-Copy is a Head-marking operation while Agree-Case is a Dependent marking operation. In the next two sections, I show how a certain type of DOM is a matter of licensing via Agree-Link and how Agree-Case can account for this type of DOM.

However before that, I briefly discuss where each of the assumed case operations occurs in the derivation.

Let me start with Agree-Case. Agree-Case is an operation that feeds off of Agree-Link relations. Hence it must follow Agree-Link. In the next few sections, I claim that Agree-Case happens after Agree-Copy applies. Given that Agree-Copy is a post-syntactic operation, Agree-Case is then also a post-syntactic operation.

Next, let us consider Inherent Case and Dependent Case. There are several reasons why Inherent Case and Dependent Case should be syntactic operations. Inherent Case requires access to lexical information and is assigned at merge along with thematic roles. Assuming that thematic roles cannot be interpreted at PF, it would be “less natural” for lexical case to be assigned post-syntactically. In addition, inherently assigned case can block overt agreement as in Hindi. In Chapter 2, I argued that in Hindi, Agree-Link establishes a relation between the agreement probe and the KP. If case were assigned after Agree-Link, we would expect Agree-Link to establish a relation between the probe and the phrase below the KP, presumably the DP or  $\pi$ P, because there is no intervening KP yet. This would predict agreement with overtly case marked nominals, which is not what we get in Hindi.<sup>6</sup> As for Dependent Case, the first reason is similar. Dependent Case can block overt agreement fully or partially as in Kurmanji. This requires Dependent Case to apply before Agree-Link in the syntax. Second, Dependent Case is restricted by syntactic domains (phases) and syntactic relations like c-command. Thus, I take it to be assigned in the syntax.

### 3.2 Licensing

The notion of licensing has been used in various theories in the Generative literature and it is an ambiguous term. Even within the domain of licensing nominals, the term has been used ambiguously. The original sense of nominal licensing was in the context of Abstract Case. During the Government and Binding era, licensing of nominals in a clause was formulated around Case Theory and Theta Theory. Besides theta marking, it was argued that each nominal needs to be licensed by being assigned Abstract Case. Although the Case Licensing

---

<sup>6</sup>One alternative to this view is Keine’s (2010) impoverishment approach which I do not adopt here. See Keine (2010) for details.

view is still maintained by many linguists (Baker and Vinokurova 2010; Legate 2008), I have provided reasons not to follow the Abstract Case view, following Marantz. Accordingly, the term licensing used in this chapter does not refer to the licensing of nominals in general via Abstract Case.

The term licensing has also been used in accounting for the distribution of a certain proper subset of nominals within a clause. In particular, nominals with participant features have been observed to behave differently from other nominals in terms of their distribution in the clause. So called Person Case Constraint (PCC) effects are a good example. In Basque, first or second person pronoun direct objects are banned under a dative indirect object (in clauses with agreement). This is known as the strong PCC in (65).

(65) Strong PCC in Basque

\*DAT  $\gg$  ABS where ABS = 1/2

(66) Zuk niri liburu-a saldu d-i- $\varphi$ -da-zu.  
 you.ERG me.DAT book-ART<sub>SG</sub>.ABS sell 3.ABS- $\sqrt{\text{SG}}$ .ABS-1SG.DAT-2SG.ERG  
 'You have sold the book to me.'

(67) \*Zuk harakin-ari niri saldu n-(a)i- $\varphi$ -o-zu.  
 you.ERG butcher-ART<sub>SG</sub>.DAT me.ABS sell 1.ABS- $\sqrt{\text{SG}}$ .ABS-3SG.DAT-2SG.ERG  
 'You have sold me to the butcher.' (Laka 1996)

The PCC facts observed in (66) and (67) have been argued to be a result of the Person Licensing Condition, by Béjar and Rezac (2003) and Preminger (2011) among others. The main idea has been that a nominal with a person (participant) feature must be licensed by a person probe via agreement. In cases when another nominal intervenes between a person probe and a participant pronoun, so that there can be no agreement between the person probe and the participant pronoun, the pronoun goes unlicensed. This yields ungrammaticality. This is why (67) is ungrammatical.

(68) *Person Licensing Condition* (Béjar and Rezac (2003, p. 53))

An interpretable 1st/2nd person feature must be licensed by entering an Agree relation with a functional category.

A similar licensing condition has been proposed by Baker (2008) to account for the SCOPA generalization. Baker observes that person agreement behaves differently from gender and number agreement in a variety of constructions in different languages. While number and gender agreement can be established at a distance, person agreement seems to obey what Baker (2008) calls the Structural Condition on Person Agreement (SCOPA).

- (69) *Structural Condition on Person Agreement* (SCOPA) Baker (2008)  
 A category F can bear the features +1 or +2 if and only if a projection of F merges with a phrase that has that feature and F is taken as the label of the resulting phrase.

In the following, I discuss some of the examples of SCOPA cases from Baker (2008, 2011). The first case is *two-and-a-half agreement* in Nahuatl.

- (70) Xi-nēch-im-maca huēhuèxōlô.  
 2SS.IMP-1SO-PL-give turkeys  
 ‘Give me some turkeys.’ Nahuatl (Baker 2011 from Launey 1981, p. 174)

In (70), while the subject and the goal argument are agreed with in person as well as number, the theme argument cannot be agreed with in person although number agreement still goes through. Following standard assumptions on double object constructions (Larson 1988), Baker argues that the goal argument can move to the Spec, *v*P while the theme argument cannot. If the agreement probe is on the *v* head, then the goal argument is local enough to satisfy SCOPA while the theme argument cannot because of the intervening V head.

Another example comes from Sakha. In Sakha, when the embedded subject remains in Spec, TP and bears nominative case, the embedded verb shows full person and number agreement with it. When the subject of the embedded clause raises into the matrix clause (or to the left periphery of the embedded clause) and gets accusative case in an ECM-like structure, person agreement with the embedded subject can fail while number agreement remains intact.



(71) Min [bügün ehigi kyaj-yax-xyt/\*tara dien] erem-mit-im.  
 I today you.NOM win-FUT-2PS/3PS that hope-PAST-1SS  
 ‘I hoped that you would win today.’

(72) Min [ehigi-ni [bügün kyaj-yax-tara] dien] erem-mit-im.  
 I you-ACC today win-FUT-3PS that hope-PAST-1SS  
 ‘I hoped that you would win today.’

Sakha (Baker 2011)

In (72), the embedded verb does not agree with the subject in person as the subject is raised into the matrix clause (skipping Spec, TP) and person agreement fails due to SCOPA.<sup>7</sup>

One further example from Baker (2011) is the agreement patterns observed with adjectival predicates. Baker (2003) argues that adjectives cannot relate to their subject arguments directly. They require an intermediate copular head to relate to their subject argument. As a result of their structures, adjectives never merge directly with their subject argument. Thus, SCOPA predicts that adjectives should never agree with their arguments in person. Baker (2011) shows that this is the case in all the languages he discusses.<sup>8</sup> One example is Spanish. In Spanish, adjectival predicates show number and gender agreement with their arguments but they cannot show person agreement.

(73) Est-as mujer-es son gord-as.  
 these-F.PL women(F)-PL are.3PS fat-F.PL  
 ‘These women are overweight.’

(74) Nosotras somos gord-as/\*gord-amos.  
 We.F.PL are.1PS fat-F.PL/fat-1P  
 ‘We (a group of females) are overweight.’

Spanish (Baker 2011, p. 879)

Baker (2008) proposes a version of Person Licensing Condition that accounts for SCOPA effects. He argues that discourse participants are introduced by speech act operators and participant pronouns are licensed if they can be “linked” with these operators introduced in the left periphery. This linking can occur only under conditions defined in (69).

In a similar vein, Ritter and Wiltschko (2014) argue that discourse participants need to

<sup>7</sup>Baker (2011) shows that person agreement with the embedded subject is optional in such clauses. The optionality is due to the possibility of skipping Spec, TP when the embedded subject moves to the left periphery.

<sup>8</sup>Baker (2011) shows that some cases where adjectives seem to be agreeing in person are actually more complex and there is no agreement on the adjective per se.

be “anchored” to the clausal spine for interpretation. More specifically, discourse participants need to be anchored to the speech act for interpretation. Kalin (2018) proposes that this anchoring is licensing through agreement. Assuming that speech acts are located in the left periphery, she argues that agreement copies these features to the clausal spine so that they can be interpreted along with the speech acts. In this model, features listed in (75) need licensing to be interpreted.

- (75)
- a. SPEAKER
  - b. PARTICIPANT
  - c. DEFINITE
  - d. SPECIFIC
  - e. ANIMATE

Features like SPEAKER and PARTICIPANT are clearly related to speech acts. In a similar vein, features like DEFINITE and SPECIFIC are also discourse related. It is not clear how animacy is related to discourse, though. Building on Ritter and Wiltschko (2014), Kalin proposes that features like animate/specific increase the possibility of a nominal becoming a discourse participant and increases its likelihood to need licensing. “Licensing” in this chapter refers to this type of licensing.

It is not clear why certain features need licensing and the proposals have not gone beyond speculations or axiomatic statements. I do not offer any deep new insights into this, either. In the remainder of this chapter, I assume that features that have a “marked” status in the discourse (speaker, addressee, participant, animate, etc.) might need licensing under well defined conditions. Languages differ in terms of what needs licensing by picking a cut-off point on what might be called discourse prominence hierarchies. The two hierarchies that are most often discussed are the *animacy hierarchy* and the *definiteness hierarchy* which have been proposed by Silverstein (1976), Comrie (1979), and Croft (1988) among others, as reviewed above, and repeated here.

- (76) Animacy Hierarchy  
 1/2 > 3 Pronoun > Name > Human > Animate > Inanimate
- (77) Definiteness Hierarchy  
 Pronoun > Name > Definite > Specific > Nonspecific

Features that need licensing can be identified as the nominals that are subject to PCC effects, SCOPA effects, and DOM.

## 4 Proposal

In this section, I present a new account of (one type of) Differential Object Marking based on the idea that “marked” nominals need licensing under well defined conditions. First, I generalize Preminger’s (2011, 2017) definition of Person Licensing Condition to capture the licensing of all “marked” nominals. Then, I propose a two-step Agree mechanism that accounts for Differential Object Marking.

### 4.1 Licensing Marked Nominals

In the previous section, I discussed strong PCC effects which have been argued to be the result of the Person Licensing Condition. The ungrammaticality of (78) has been attributed to the impossibility of agreement between the theme argument and a probe.

- (78) \*Zuk harakin-ari niri saldu n-(a)i- $\varphi$ -o-zu.  
 you.ERG butcher-ART<sub>SG</sub>.DAT me.ABS sell 1.ABS- $\sqrt{\text{}}$ -SG.ABS-3SG.DAT-2SG.ERG  
 ‘You have sold me to the butcher.’ (Laka 1996)

Béjar and Rezac (2003) argued that nominals with person features must be licensed by entering into an Agree relation with a functional category. However, Preminger (2011) observes that first and second person pronouns can occur in environments where they are not agreed with. The presence of PCC effects is correlated with the existence of overt agreement morphology in the vicinity. In Basque, non-finite clauses do not display agreement. In this context, PCC effects disappear, as in (79).

- (79) Gaizki irudi-tzen  $\varphi$ -zai- $\varphi$ -t [zuk ni harakin-ari  
 wrong look-IMPF 3.ABS- $\sqrt$ -SG.ABS-1SG.DAT you.ERG me.ABS butcher-ART<sub>SG</sub>.DAT  
 al-tze-a].  
 sold-NMZ-ART<sub>SG</sub>.ABS  
 ‘It seems wrong to me for you to sell me to the butcher.’ (Laka 1996)

Preminger (2019) also shows that the PCC effects correlate with overt agreement rather than finiteness. In Spanish, there is overt object agreement (in the form of pronominal clitics) in infinitival clauses and the PCC effects persist.

- (80) \*Recomendár-me-los es una sorpresa.  
 recommend.INF-CL<sub>1SG</sub>-CL<sub>3PL</sub> COP DET<sub>F.SG</sub> surprise  
 ‘Recommending me to them is a surprise.’  
 (OK as: ‘Recommending them to me is a surprise.’) Spanish (Preminger 2017)

Based on the correlation between PCC effects and overt agreement, Preminger (2011) proposes the Person Licensing Condition in (81).

- (81) Person Licensing Condition Preminger (2011)  
 A [PARTICIPANT] feature on a DP that is a viable agreement target (as far as its case is concerned, etc.), and for which there is a clausemate person probe, must participate in a valuation relation.

The licensing condition given in (81) requires nominals with a [PARTICIPANT] feature to be licensed in some but not all contexts. A closer look at the PLC in (81) reveals that it consists of three conditional statements:

- (82) A nominal requires licensing if
- a. it has a specific feature (PARTICIPANT)
  - b. it is in the same domain as an agreement probe (a PERSON probe)
  - c. it is a viable agreement target, i.e. it has the right case (etc.)

If any of these conditions is not met, person licensing is not required and PCC effects disappear. For example, a third person pronoun lacks a [PARTICIPANT] feature and is not subject

to the PLC. This is why in Basque, an absolutive third person theme c-commanded by a dative goal is grammatical. Similarly, if (82-b) does not hold, then person licensing is not required. The lack of an agreement probe in the same domain as a nominal with person features removes the need for person licensing. Infinitival clauses in Basque like in (79) support this point. There is no agreement probe in the infinitival clause and PCC effects do not occur. Finally, if the condition in (82-c) is not met, person licensing is not required. For example, if an NP with a person feature is in oblique case in a language where oblique case renders a nominal invisible for agreement, then person licensing is not required.

Extending Preminger's PLC, I propose the following condition for licensing of nominals that bear a wider range of discourse related features.

(83) Feature Licensing Condition

A nominal N with a feature F ( $N_{[F]}$ ) must enter an agreement relation with a probe P with a matching F ( $P_{[F]}$ ) if N is visible to P.

(84) F is a feature drawn from animacy/specificity hierarchies and varies depending on the language.<sup>9</sup>

The Feature Licensing Condition in (83) predicts PCC effects when a language requires [PARTICIPANT] features to be licensed. It also predicts PCC-like effects with other features including [ANIMATE, SPECIFIC, DEFINITE], etc. If a language requires [ANIMATE] nominals to be licensed, then we should expect PCC like effects with [ANIMATE] nominals. Although rare, this is attested in Mohawk (Baker 1996) and Southern Tiwa (Richards 2008). Similarly, we also get the same constraint with [DEFINITE/SPECIFIC] nouns in Akan (Richards 2008). I argue that PCC-like effects with features other than [PARTICIPANT] are common but most of the time such effects are disguised by Differential Object Marking, which repairs the illegitimate structure that leads to PCC effects. In Section 5, I apply this to PCC-like effects in Kashmiri based on animacy. Then in Section 7, I discuss PCC like effects in Senaya based

---

<sup>9</sup>The simplest designation of F is a single feature rather than a set of features. As outlined below, any nominal that needs licensing contains this feature. For example, in Turkish  $F = [+SPECIFIC]$ . Specific nouns must be licensed. In Turkish, definite nouns also need licensing. This is because a definite noun is also specific. The structure of a definite NP includes a [+SPECIFIC] feature.

on specificity.

#### 4.2 Licensing, PCC, and DOM

Similarities between PCC and DOM have been noted in the literature. Kalin (2016) shows that both PCC and DOM occur in configurations where a probe c-commands two goals. This is shown in (85).

(85) PCC/DOM Configuration (Kalin 2016)

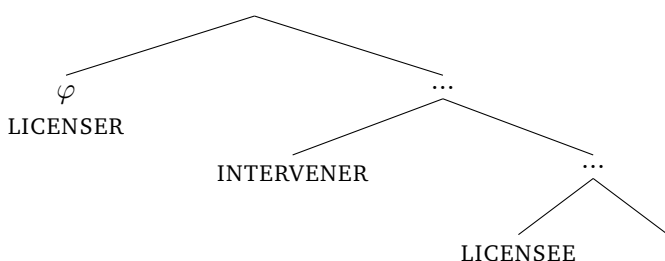

The mainstream view (Béjar and Rezac 2003; Kalin 2017, 2018; Preminger 2011) has been that, in this configuration, the intervening nominal prevents the probe from seeing the lower nominal. When the lower nominal bears a feature that needs licensing, the configuration leads to ungrammaticality, resulting in a PCC effect. Kalin (2018) argues that, in such cases, if a language has a way of introducing additional probes as a last resort mechanism, the added probe can license the lower nominal, which is realized as Differential Object Marking.<sup>10</sup> The added probe can be realized as extra agreement or overt case marking on the licensee.<sup>11</sup>

Kalin's proposal is based on the assumption that a noun phrase with a particular feature F always needs licensing. This predicts a static DOM where an object with F is always differentially marked. This, however, falls short of capturing the Kashmiri facts discussed in (52) and (53) repeated below.

<sup>10</sup>Béjar and Rezac (2009) make a similar proposal except that the extra probe is added to license the higher of the two goals rather than the lower one.

<sup>11</sup>One prediction of the proposal is that the added probe can surface as both agreement and case.

(86) **hu** ch-u                    **tse** / \*tʃi tul-a:n.  
 he.Ø be.PRES-M.SG you.DAT / you.Ø lift-PTCP.PRES  
 ‘He is lifting you.’

(87) **bi** ch-u=s                    **tʃi** / \*tʃe tul-a:n.  
 I.Ø be.PRES-M.SG=1SG you.Ø / you.DAT lift-PTCP.PRES  
 ‘I am lifting you.’

In both (86) and (87), the object is second person. While the object gets dative in (86), it remains unmarked in (87). Note that the agreement facts are the same in both cases. The verb agrees with the subject in gender and number. The fact that nominals with F do not always need licensing despite the availability of a probe with F motivates the *visibility* condition in the FLC proposed in (83). I argue that in (86) and (87), the visibility of the objects is not the same. Therefore, I propose an alternative analysis of PCC and Differential Object Marking effects that is based on Multiple Agree rather than on intervention. This account captures Differential Object Marking in languages like Kashmiri and Senaya where DOM is related to licensing but not dependent case.

In Chapter 2, I adopted a two-step Agree model in which Agree-Link establishes Agree relations in the syntax while Agree-Copy translates these relations into values by copying the phi sets from the goals to the probes. I have also made a distinction between two types of Agree-Link operations to explain the differences between languages where Agreement is only with the closest goal and ones with multiple agreement relations. The operations are listed below.

(88) a. **Agree-Link**<sub>Multiple</sub> establishes a relation between a probe P and all goals G within the local c-command domain of P by adding pointers ( $\rightarrow$ ) from P to each of the Gs. (For simplicity, I call this Multiple Agree in the following.)

Schematically, given a probe P and goals  $\{G_1, \dots, G_n\}$ , Multiple Agree returns:

$$P \begin{bmatrix} \rightarrow G_1 \\ \rightarrow G_2 \dots \\ \rightarrow G_n \end{bmatrix}$$

b. **Agree-Link**<sub>Single</sub> establishes a relation between a probe P and the closest goal G in the local c-command domain of P by adding a pointer ( $\rightarrow$ ) from P to G.

(89) **Agree-Copy**

Agree-Copy takes as input a substructure of the form  $P_{[\rightarrow G]}$  and returns  $P_{\{\{\pi, \#, \gamma\}\}}$  by replacing the pointer(s) associated with P with the  $\varphi$ -set at G.

One thing that I did not discuss was the details of the operation of Agree-Copy. Does it replace all the pointers simultaneously or does it work cyclically? I now argue that Agree-Copy works cyclically starting with the closest goal  $G_1$  and keeps copying features from lower goals  $G_n$  sequentially.<sup>12</sup> PCC effects and DOM occur in cases when a multiply-linked probe can host only one set of  $\varphi$ -features. The remaining pointers (relations) cannot be interpreted at PF yielding a crash. More explicitly, Vocabulary Insertion cannot interpret the pointers on the probe. PCC effects occur when there is no other mechanism to interpret the pointers. Differential Object Marking occurs in languages with Agree-Case which can transduce the remaining pointers into case marking on the goal. The order of operations is given in (90).

(90) Agree-Link  $\prec$  Agree-Copy(Head Marking)  $\prec$  Agree-Case (Dependent Marking)

Differential Object Marking is then a way of expressing a syntactic Agree relation without overt agreement but through case marking. It should be noted that Agree-Case is not a *last resort* mechanism. It is a morphological operation that applies when conditions are met. Agree-Case is just like Agree-Copy in that it dereferences the pointers established by Agree-Link. The only difference is that it marks the relation on the goal but not the probe. This proposal operationalizes the idea of Head Marking and Dependent Marking (Nichols 1986). It also predicts that a language can have both Head Marking and Dependent Marking. In the next section, I show how the theory proposed here accounts for the Kashmiri facts discussed in Section 2.

<sup>12</sup>This is somewhat anti-cyclic, moving from the top of the tree downward. Following the discussion of Minimal Search in Chapter 3, I assume that structure building is bottom-up but Minimal Search is top-down. By transitivity, operations that need Minimal Search (Agree-Link, Agree-Copy, etc.) are also top-down.



## 5 Analysis: Kashmiri DOM

In this section, I apply the theory proposed in the previous section to analyze Kashmiri Differential Object Marking Facts. First, I provide an analysis of clauses with objects that are non-pronominal noun phrases as well as an analysis of aspect based DOM in Kashmiri. Then, I extend the analysis to account for the Animacy Hierarchy effects in Kashmiri.

### 5.1 Noun Phrase Objects and the Aspect Split

Let us first take a look at Differential Object Marking in non-pronominal animate noun phrases. In Kashmiri, specific animate noun phrases receive DOM in non-perfective aspects. One such example was given in (39), repeated below.

- (91) az vuchan daaktar **mariiz-as** waarpaathyii.  
 today see.FUT.3PL doctors patient-DAT carefully  
 'Today, the doctors will examine the patient carefully. (Bhatt 2013, p. 176)

The relevant structure of (91) is given in (92).

- (92) *Output of Agree-Link*

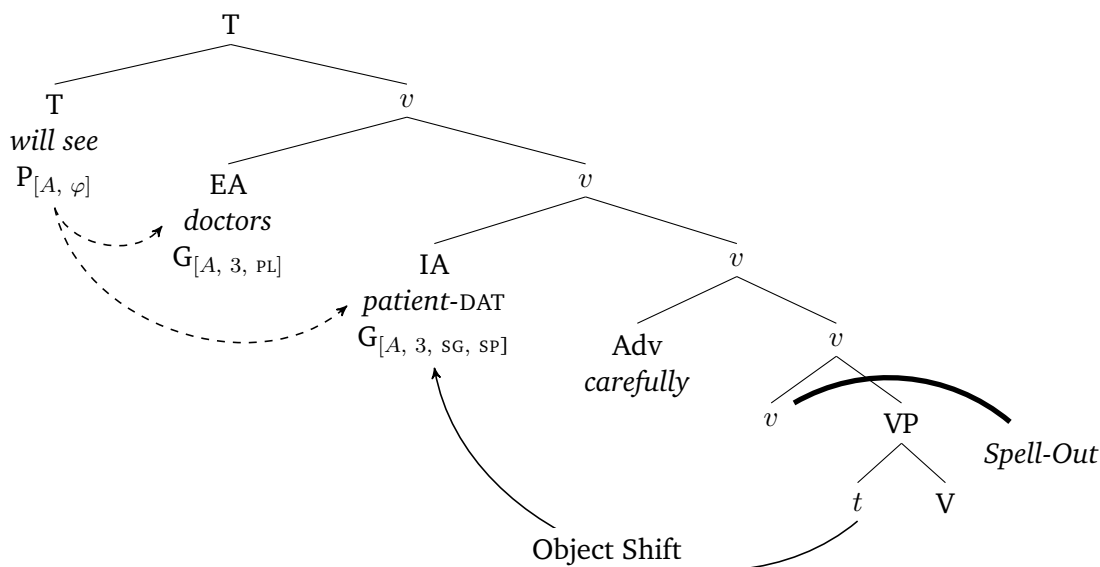

In (92), the internal argument is specific and moves out of the VP and tucks in under the external argument (in Richards 1997 sense). This movement is supported by the fact that the specific object precedes the adverb *waarpaathyii* ‘carefully’. If the object is non-specific, it has to follow the adverb as in (39). Once the internal argument is in the same phase as the agreement probe on T, it becomes visible for agreement. Multiple Agree applies to satisfy the Feature Licensing Condition for [+ANIMATE] in this configuration. The agreement probe on T establishes Agree-Link relations with both the external argument and the internal argument. The relations established by Agree-Link are represented with pointers. Schematically, this is expressed in (93).

$$(93) \quad \text{P} \left[ \begin{array}{l} \rightarrow G_{EA} \\ \rightarrow G_{IA} \end{array} \right]$$

In the second stage of agreement, Agree-Copy applies cyclically to replace the pointers with feature values. In Kashmiri, the agreement probe can host only one set of non-empty  $\varphi$ -features. Once the feature values of the subject are copied, there is no room for the feature values from the object. This leaves the agreement probe with one set of feature values and one pointer as in (94).

$$(94) \quad \text{P} \left[ \begin{array}{l} A, 3, PL \\ \rightarrow G_{IA} \end{array} \right]$$

The unresolved pointer on the probe is an illegitimate object for Vocabulary Insertion. Kashmiri resolves this issue by resolving the relation between the probe and the internal argument by marking the internal argument rather than the probe. The output of Agree-Copy is given in (95)

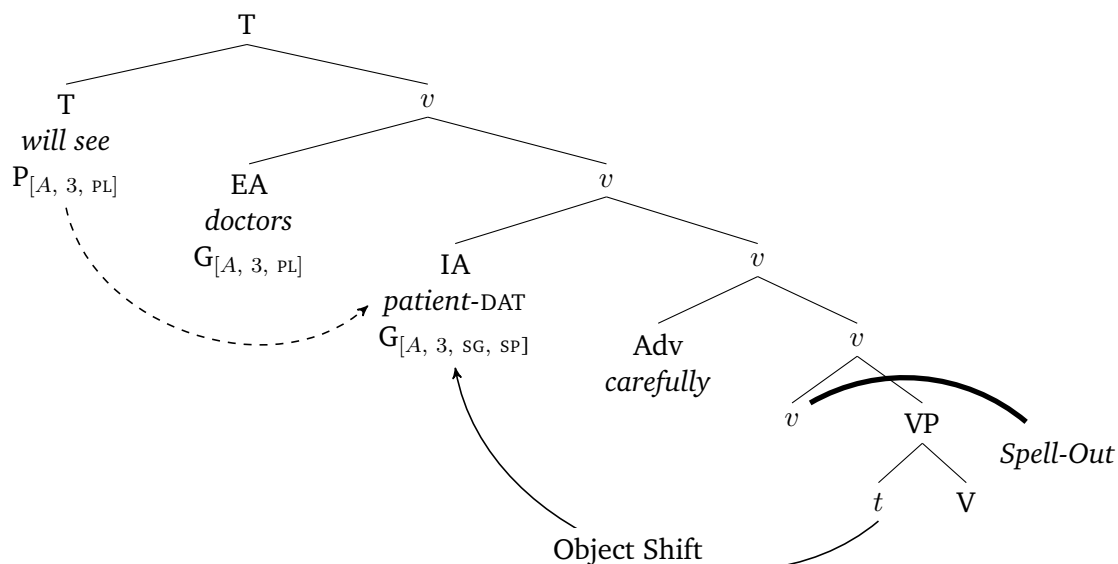
(95) *Output of Agree-Copy*

When the output of Agree-Copy is fed into Agree-Case, Agree-Case translates the Agree-Link relation to dative case by removing the pointer and marking the object dative. Thus the specific animate object receives dative case as it is agreed with in the syntax but this relation cannot be transduced into a valuation relation on T. Instead, the relation is transduced into case on the goal. This analysis has the potential to account for the fact that overtly agreed with nouns never get overt case in Kashmiri.

Next, let us consider a clause with an animate but non-specific common noun. The example was given in (40), repeated here for convenience.

- (96) az vuchan daaktar waarpaathyii mariiz.  
 today see.FUT.3PL doctors carefully patient  
 'Today, the doctors will examine a patient carefully. (Bhatt 2013, p. 177)

The key difference between (96) and (91) is that (96) has a non-specific object that follows the adverb *waarpaathyii* 'carefully'. Although the object is animate, it does not receive differential dative case. The relevant structure of (96) is given in (97).

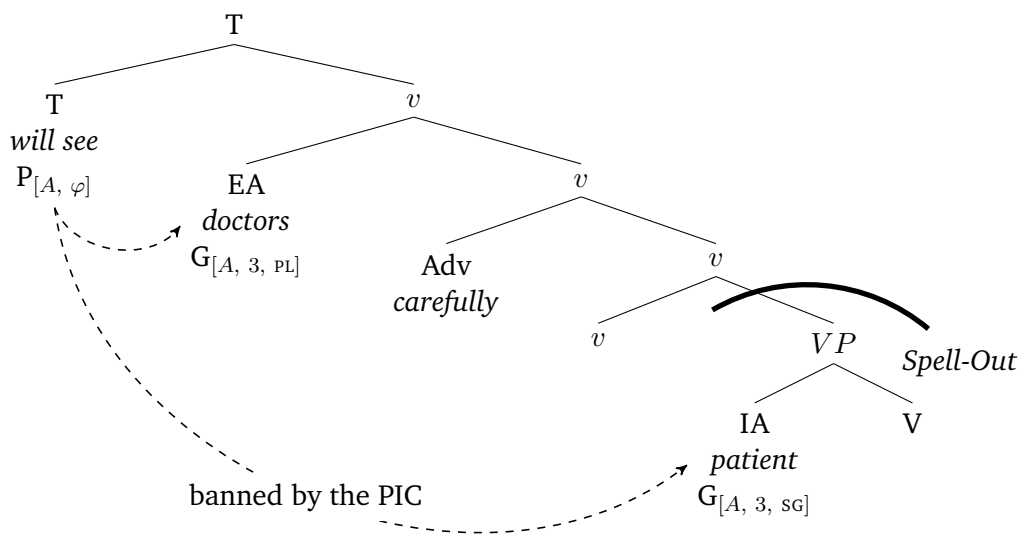
(97) *Output of Agree-Link*

In (97), the internal argument is not specific and stays inside the VP. Thus, it is never visible to the agreement probe on T because they are in different phases. When Agree-Link applies, it establishes a relation between the probe and the external argument only. When Agree-Copy applies, the only agreement relation between the subject and the probe is transduced into valuation. Since there are no other Agree-Link relations, Agree-Case does not apply and the internal argument remains caseless.

So far, I analyzed DOM on common nouns in non-perfective clauses. In perfective clauses, Differential Object Marking is absent no matter what the properties of the internal or external arguments are. Consider the following example.

- (98) timav vuch **mohni** ə:nas manz.  
 3PL.ERG saw.M.SG mohan mirror in  
 'They saw Mohan in the mirror.' (adapted from Wali and Koul 1997, p. 130)

In (98), the clause is perfective. The subject is in ergative case and the object is caseless despite being animate and specific. In Kashmiri perfective clauses, the verb does not show agreement with ergative subjects. Instead, it shows agreement with the caseless object in number and gender. In (98), the subject is third plural while the object is third singular

masculine. The auxiliary verb *vuch* has masculine singular agreement cross-referencing the internal argument. The reason why objects do not get DOM in perfective clauses is that the Agree-Link relation between the T and the object can be transduced into valuation. This is possible in perfective clauses because the ergative subjects do not provide the probe with any  $\varphi$ -values. The relevant Agree-Link structure of (98) is given in (99).

(99) *Output of Agree-Link*

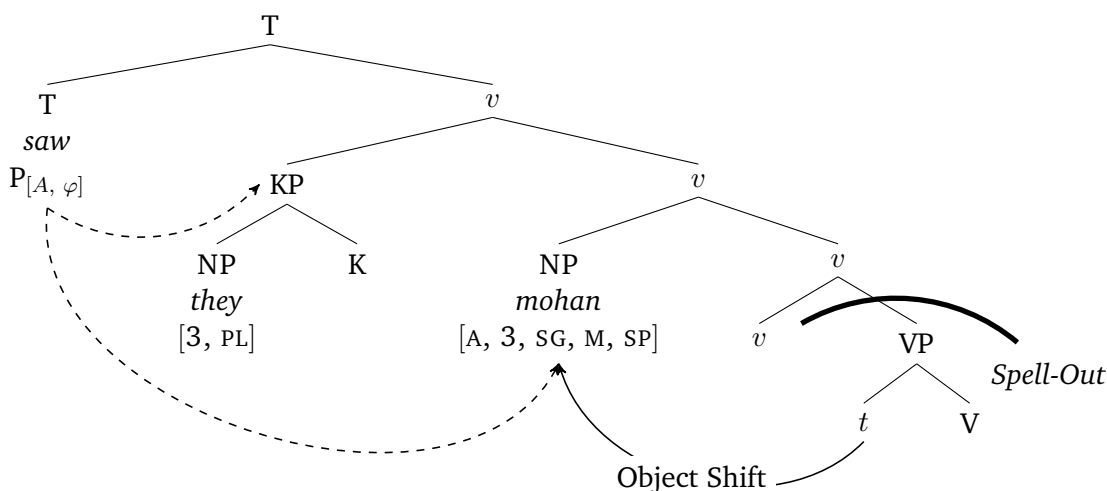

In (99), T establishes two relations, one with the subject and the other with the object. Next, the structure is fed into Agree-Copy. Agree-Copy applies cyclically and copies features from the goals starting with the closest one, i.e. the subject. In the first iteration, Agree-Copy returns an empty set because the ergative subject cannot provide any  $\varphi$ -values due to the extra K structure. This makes it possible for Agree-Copy to run a second cycle to consider the object this time and copy its  $\varphi$ -values. This second round also removes the pointer from the probe. Therefore, when Agree-Case applies, it does not find any pointers, so, differential dative case is not assigned. Thus, the difference between perfective and non-perfective clauses in terms of Differential Object Marking follows from the valuation processes in each case. In non-perfective clauses, the subject is not a KP. Thus, it values the probe and thus the object cannot value the probe as the probe, since it has already been valued by the subject. The pointer for the object causes a problem for PF Interpretation. This

problem is resolved by Agree-Case which takes an unresolved Agree-Link relation between the probe and the goal and resolves it by marking the object with case. In perfective clauses, the subject is ergative and cannot value the probe, as KPs in Kashmiri do not value probes. This time, the Agree-Link relation between the probe and the object can result in valuation, which removes the pointer.

## 5.2 Entailment Relations and the Hierarchy Effects

In Section 5.2, I discussed the implicational nature of the Animacy Hierarchy and the Specificity Hierarchy. Differential marking of a lower ranking element on these hierarchies imply the differential marking of a higher ranking element.

(100) Animacy Hierarchy

1/2 > 3 Pronoun > Name > Human > Animate > Inanimate

If Human objects get Differential Object Marking, then all the objects ranking higher than Human also get Differential Object Marking. Recent work on these entailment relations builds on the idea that various features are distributed across the extended nominal projection. Kalin (2018) proposes a set of heads that introduce features like specificity, definiteness, animacy, etc. without imposing any particular order of merge amongst themselves.

(101) Heads in the Extended Nominal Projection (Kalin 2018, p. 31)

- a. Participant (semantically encoding first/second person)
- b. Person (semantically encoding person)
- c. Human (semantically encoding humanness)
- d. Animate (semantically encoding animacy) Name (semantically encoding the property of being a proper name)
- e. Definite (semantically encoding definiteness)
- f. Specific (semantically encoding specificity)
- g. Number (semantically encoding number)

These heads are equivalent to privative features and are projected when the nominal has

the meaning encoded by such heads. The presence of certain features entails the presence of other features. For example, a [PARTICIPANT] feature entails the presence of [PERSON, ANIMATE, HUMAN] features. Hence, if a language employs Differential Object Marking for animacy, then Differential Object Marking for first and second person pronouns is entailed as they also have the feature [ANIMATE].

A similar idea has been proposed by Barány (2017). Focusing on person features, Barány (2017) argues that person features are in fact sets of features that consist of other features and the entailment relations among person features follow from the subset-superset relations among these sets. In this model, pronouns can consist of [SPEAKER], [PARTICIPANT], and [ $\pi$ ] (person) features.

$$(102) \quad [1] = \left\{ \begin{array}{l} \text{SPEAKER,} \\ \text{PARTICIPANT,} \\ \pi \end{array} \right\} \quad [2] = \left\{ \begin{array}{l} \text{PARTICIPANT,} \\ \pi \end{array} \right\} \quad [3] = \left\{ \pi \right\}$$

The pronouns in (102) are in subset-superset relations. For example, a second person pronoun is a subset of a first person pronoun. The entailment relations are established through such set-theoretical relations. For example, if a second person pronoun needs Differential Object Marking, then a first person pronoun requires DOM because it has all the features possessed by the second person pronoun. Following Kalin (2018) and Barány (2017), I assume that the entailment relations follow from the subset-superset relations among the nominals. In particular, I adopt Barány's abstract characterization of such subset-superset relations by using small capital letters for features on Animacy Hierarchies as in (103). The same mechanism applies to Definiteness Hierarchies.

$$(103) \quad \begin{array}{lll} \text{a. } 1 & = & \{A, B, C, D, E, F\} \\ \text{b. } 2 & = & \{A, B, C, D, E\} \\ \text{c. } 3 & = & \{A, B, C, D\} \\ \text{d. } \text{NAME} & = & \{A, B, C\} \\ \text{e. } \text{HUMAN} & = & \{A, B\} \\ \text{f. } \text{ANIMATE} & = & \{A\} \\ \text{g. } \text{INANIMATE} & = & \emptyset \end{array}$$

Given the subset-superset relations among nominals on this view, entailment relations

can be accounted for straightforwardly. Regardless of the mechanism assigning DOM, if a language differentially marks a noun with the feature [B], which distinguishes a HUMAN object from non-HUMAN objects, then any noun that has the feature [B] gets DOM. This generalization is too strong though in certain special cases. In the next section, I discuss animacy hierarchy effects in Kashmiri which require a reformulation of the implicational generalization.

### 5.3 Animacy Hierarchy Effects

One of the crucial facts about Kashmiri Differential Object Marking is that the implicational hierarchy observed in many other languages seems not to obtain in Kashmiri. For example, as shown in (3), Turkish objects get DOM when specific. DOM on a specific indefinite noun phrase implies that all the items to the left of the “specific” on the Definiteness Hierarchy receive DOM.

(104) Definiteness Hierarchy

Pronoun > Name > Definite > Specific > Nonspecific

In Turkish, all the definite nouns, names and pronouns receive Differential Object Marking. In Kashmiri, this is not the case. For example, an animate common noun can receive DOM as in (105) but this does not entail that a pronoun necessarily gets Differential Object Marking.

(105) hu ch-u            lə**dk-as** tul-a:n.  
3SG be.PRES-M.SG boy-DAT lift-PTCP.PRES  
'He is lifting the boy.'

For example, a second person pronoun can receive DOM, but not always. This was shown in (52) - (53), repeated below for convenience.

(106) **hu** ch-u            **tse** / \*tʃi tul-a:n.  
he.Ø be.PRES-M.SG you.DAT / you.Ø lift-PTCP.PRES  
'He is lifting you.'



- (107) **bi** ch-u=s                      **tsi** / \*tse      tul-a:n.  
 I.Ø be.PRES-M.SG=1SG you.Ø / you.DAT lift-PTCP.PRES  
 'I am lifting you.'

In Kashmiri, then it is fair to say that the implicational hierarchy does not hold the straight-forward way it does in other languages. Yet, It can still be maintained with a slight modification, as in (108).

- (108) If a lower ranking element on the animacy hierarchy can receive Differential Object Marking, then a higher ranking element can also receive Differential Object Marking.

Instead of a strict implicational hierarchy, Kashmiri has a different sort of Animacy Hierarchy effect. In Kashmiri, an object receives DOM when the subject ranks lower than or equal to the object on the Animacy Hierarchy. How can the two-step Agree mechanism account for this sort of hierarchy effect?

Following Barány (2017) and Kalin (2018), I assume that a higher ranking element on a hierarchy has a richer structure than a lower ranking element. Adopting the set theoretic approach in Barány 2017, I take the structures of the elements on the Animacy Hierarchy to be as in (109).

- (109)
- |    |           |   |                    |
|----|-----------|---|--------------------|
| a. | 1         | = | {A, B, C, D, E, F} |
| b. | 2         | = | {A, B, C, D, E}    |
| c. | 3         | = | {A, B, C, D}       |
| d. | NAME      | = | {A, B, C}          |
| e. | HUMAN     | = | {A, B}             |
| f. | ANIMATE   | = | {A}                |
| g. | INANIMATE | = | Ø                  |

In Barany's model, the hierarchies can be derived from the subset-superset relations among the elements on the hierarchy. An element A that is a proper subset of another element B ranks lower than B. This can be formulated as in (110).

- (110)  $B > A$  if  $A \subset B$

For Kashmiri, the relevant elements are {SPEAKER, PARTICIPANT, ANIMATE, INANIMATE}. The

abstract structures of these elements can be represented as in (111).

- (111)
- |    |           |   |                                 |
|----|-----------|---|---------------------------------|
| a. | 1         | = | {SPEAKER, PARTICIPANT, ANIMATE} |
| b. | 2         | = | {PARTICIPANT, ANIMATE}          |
| c. | ANIMATE   | = | {ANIMATE}                       |
| d. | INANIMATE | = | ∅                               |

The elements in (111) establish the Kashmiri Animacy Hierarchy by (110).

- (112) Kashmiri Animacy Hierarchy

*Speaker > Participant > Animate > Inanimate*

In the previous section, I argued that Kashmiri has Multiple Agree, and Differential Object Marking occurs as a result of this Multiple Agree which creates two agreement relations (pointers) in the syntax, one of which cannot be dereferenced via Agree-Copy. The Agree-Link relation that cannot be removed by Agree-Copy causes trouble for PF Interpretation as pointers cannot be interpreted by Vocabulary Insertion. This problem is resolved by Agree-Case, which marks the object (Dependent Marking) and removes the pointer. This theory predicts that all the specific objects in Kashmiri must receive Differential Object Marking when the clause is non-perfective. Consider the following sentence, which seems to be a counterexample:

- (113) **bi** ch-u=s                      **tsi** / \*tse      tul-a:n.  
 I.∅ be.PRES-M.SG=1SG you.∅ / you.DAT lift-PTCP.PRES  
 'I am lifting you.'

In (113), the auxiliary shows overt agreement with the subject. The object is a second person pronoun, hence specific. Thus, it must be visible for Multiple Agree since specific objects in Kashmiri move out of the lower phase and into the domain of the agreement probe. The structure of (113) should be as in (114).

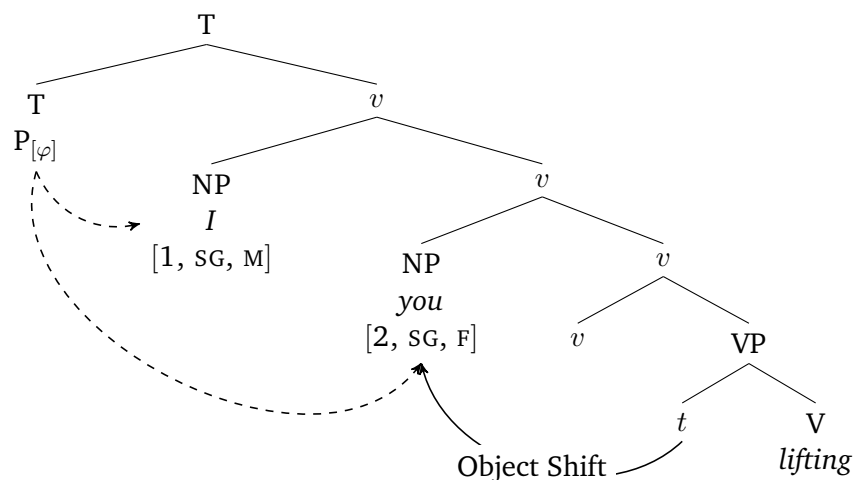
(114) *Output of Agree-Link*

In this configuration, the verb should establish two Agree-Link relations in the syntax. At PF, Agree-Copy can remove the relation between the subject and the probe by transferring the features of the subject to the probe. Yet, the second relation cannot be turned into valuation since the probe already has a non-empty set of features. The remaining pointer should cause trouble for Vocabulary Insertion and the object should receive Agree-Case so that the pointer is removed. Yet, the object remains caseless. The same problem obtains in all the configurations where the object ranks lower than the subject on the Animacy Hierarchy. Here are some other problematic cases.

(115) *bi ch-u=s ləɖki tul-a:n.*  
 1SG.Ø be.PRES-M.SG=1SG boy.Ø lift-PTCP.PRES  
 'I am lifting the boy.'

(116) *tsi ch-u=kh yi tul-a:n.*  
 you.Ø be.M.SG=2SG 3SG.Ø PTCP.PRES  
 'You are lifting him.'

(117) *tsi ch-u=kh ləɖki tul-a:n.*  
 you.Ø be.M.SG=2SG boy.Ø PTCP.PRES  
 'You are lifting the boy.'

When the subject is higher than the object on the animacy hierarchy, the object remains

unmarked. In set theoretical terms, when the features of the object are a proper subset of the features of the subject, the object remains unmarked. This is expressed in (118).

- (118) If  $O_{\varphi} \subset S_{\varphi}$ ,  
then O is unmarked.

I argue that the facts discussed above can be explained by the visibility condition on the Feature Licensing Condition in (83) repeated below for convenience.

- (119) *Feature Licensing Condition*  
A nominal N with marked feature F ( $N_{[F]}$ ) must enter an agreement relation with a probe P with a matching F ( $P_{[F]}$ ) if N is **visible** to P.

The Feature Licensing Condition, which enforces Multiple Agree in Kashmiri, applies only when a nominal is visible to an agreement probe. While movement of a nominal into the same phase as the agreement probe is a necessary condition for visibility, it is not sufficient. Visibility of a nominal to a probe can further be restricted by other factors like Relativized Minimality. In Chapter 2, I adopted the view that Relativized Minimality is not a concern in Multiple Agree contexts. I now add a visibility qualification to the Multiple Agree proposal.

- (120) *Multiple Agree*  
**Agree-Link**<sub>Multiple</sub> establishes a relation between a probe P and all the **visible** goals G within the local c-command domain of P by adding pointers ( $\rightarrow$ ) from P to each of the visible Gs.

- (121) *Visibility Condition (on Multiple Agree)*  
A goal G is visible to a probe P across another goal G' only if  $\varphi$ -features of G' are a subset of G.

The Visibility Condition in (121) implies that when the subject is between the object and the agreement probe, the object is visible to the probe only if the object has the same features as the subject or more features than the subject. Otherwise, the object is not visible and

the probe agrees with the subject only. The configurations in which an object is visible to the agreement probe ((122)) lead to PCC effects or Differential Object Marking while other configurations ((123)) do not lead to PCC effects or DOM because the object is not agreed with in the syntax.

(122) PCC/DOM Configurations

- a.  $3 \gg^{13} 1$
- b.  $3 \gg 2$
- c.  $3 \gg 3^{14}$
- d.  $2 \gg 1$

(123) No Object Agreement (via Multiple Agree)

- a.  $1 \gg 2$
- b.  $1 \gg 3$
- c.  $2 \gg 3$

Given the Visibility Condition, the lack of DOM in (113), which has the configuration in (123-a) is due to the invisibility of the object. The output of the Agree-Link is as in (124).

---

<sup>13</sup>Indicates structural prominence. In traditional terms,  $\gg$  indicates c-command. In the Minimal Search-based alternative discussed in Chapter 3, it indicates structural precedence in a search path.

<sup>14</sup>This seems to vary depending on the language. While in Kashmiri, this configuration leads to DOM, according to Barány (2017), it does not cause DOM in Hungarian.

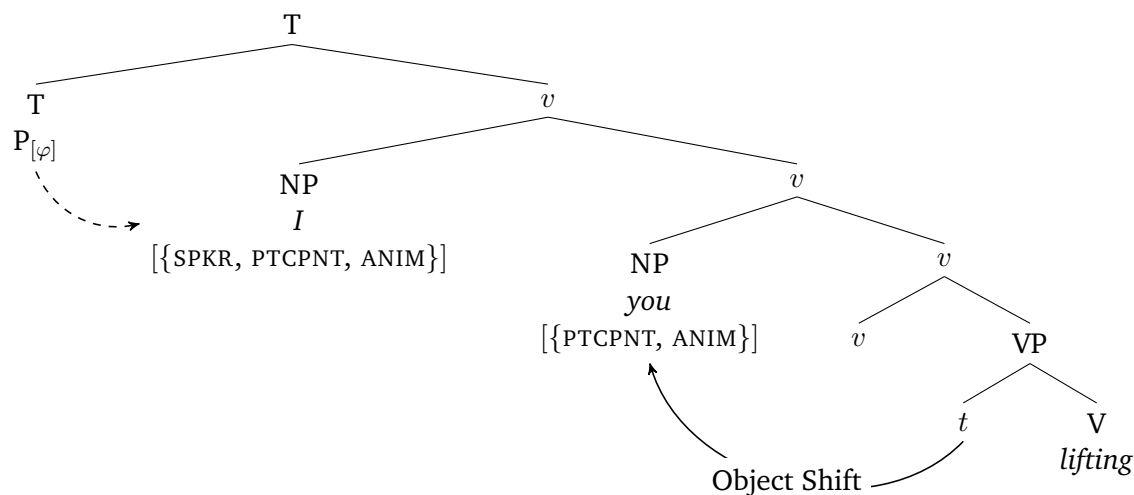
(124) *Output of Agree-Link*

In (124) the probe only agrees with the external argument but not with the internal argument since the internal argument is not visible to the agreement probe. When the output of Agree-Link is sent to Agree-Copy, it dereferences the only pointer on the probe by copying the features of the subject on the probe. There is no other pointer on the probe. The conditions for Agree-Case are not satisfied, and hence Agree-Case does not apply, resulting in no DOM on the internal argument.

The configuration in (122-c) deserves some further discussion. In Section 2, I have shown that third person is a broad categorization and it contains both animate and inanimate nominals. I have shown that in Kashmiri, animate specific objects receive DOM in 3 > 3 configurations ((125)) but inanimate objects do not ((126)).

(125) hu ch-u            **p'a:li** tul-a:n.  
 3SG be.PRES-M.SG cup lift-PTCP.PRES  
 'He is lifting the cup.'

(126) hu ch-u            **lɔdk-as** tul-a:n.  
 3SG be.PRES-M.SG boy-DAT lift-PTCP.PRES  
 'He is lifting the boy.'

These facts can also be captured by the Visibility Condition in (121). In , the object is inanimate whereas the subject is animate. The features of the subject are not a subset

of the features of the object. Therefore, the object is not visible to the agreement probe even though it is specific. On the other hand, in (126), both the object and the subject are animate. In terms of discourse related features, the features of the subject are a subset of the features of the object. This makes the object visible to the agreement probe, resulting in differential object marking. Clearly, in (126), the pronoun versus common noun distinction does not come to play. In other words, third person pronouns in Kashmiri do not count as supersets of animate common nouns and thus they do not have any influence on the visibility of animate common nouns. This can be interpreted as some evidence for the lack of a person specification in Kashmiri third person pronouns.

One final configuration that is predicted to result in Differential Object Marking in Kashmiri is the  $3 > 3$  configuration where both of the arguments are inanimate. The Visibility Condition predicts the object to receive DOM case in this configuration. Unfortunately, I do not have data to confirm this prediction. In a casual conversation with my consultant, I was able to elicit an utterance with the *INANIM > INANIM* configuration where the object received DOM but I did not have the chance to note the utterance. I was not able to control for other variables for this example either. The utterance was the Kashmiri counterpart of ‘The rock smashed the window.’<sup>15</sup>

One last point about the  $3 > 3$  configurations is about the cross-linguistic variation.  $3 > 3$  configuration does not lead to PCC effects very often. In a similar vein, Barány (2017) shows that  $3 > 3$  configuration does not lead to DOM in Hungarian. I have shown that in Kashmiri,  $3 > 3$  is a coarse generalization and the presence of DOM in  $3 > 3$  configurations is identified by the animacy of the object. Some further details might be at play in languages where  $3 > 3$  does not lead to PCC. Another possible way of accounting for the cross-linguistic variation in  $3 > 3$  configurations is to parameterize the Visibility Condition as in (127), where the parentheses around “proper” indicate a parameterization.

(127) *Visibility Condition (on Multiple Agree) - Parameterized*

A goal *G* is visible to a probe *P* across another goal *G'* only if  $\varphi$ -features of *G'* are a (proper) subset of *G*.

---

<sup>15</sup>Mark Baker (p.c.) reports that in Spanish *INANIM > INANIM* configuration yields DOM in some cases.

Before closing the section on Kashmiri Differential Object Marking, let me show how the theory of case and agreement developed so far accounts for the asymmetric DOM facts observed in Kashmiri. In Section 1.2, I showed that Kashmiri allows the coordination of a DOM marked object with an unmarked object. The relevant data is provided below.

(128) ?tsi ch-u=kh yi tɪ me tul-a:n.  
 you.Ø be.M.SG=2SG 3SG.Ø and 1SG.DAT lift-PTCP.PRES  
 'You are lifting him and me.'

(129) ?tsi ch-u=kh me tɪ yi tul-a:n.  
 you.Ø be.M.SG=2SG 1SG.DAT and 3SG.Ø PTCP.PRES  
 'You are lifting me and him.'

Data like (128) - (129) are challenging to many theories of DOM. Kalin and Weisser (2017) discuss this sort of asymmetric DOM data as evidence against movement theories of DOM. Their main argument goes as follows. The coordinated objects are subject to the Coordinate Structure Constraint (CSC) (Ross 1967). Moving one of the conjuncts requires the movement of the entire ConjP since extraction out of a ConjP is (usually) banned. If DOM is purely the result of movement, given CSC, asymmetric DOM should not be allowed. I concur with Kalin and Weisser (2017) in that DOM cannot be explained by movement only. However, I argue that movement can be a step in the analysis of Differential Object Marking. In the licensing-based DOM approach developed in this chapter, movement is a necessary but insufficient condition for DOM in languages where *v*P introduces a phase boundary.

Let me present the account through the analysis of the example in (129). The relevant structure of (129) is given in (130) below.<sup>16</sup>

---

<sup>16</sup>The actual structure of the conjunction phrase is not relevant for the analysis. The same analysis applies even if the conjunction phrase were right descending or flat.

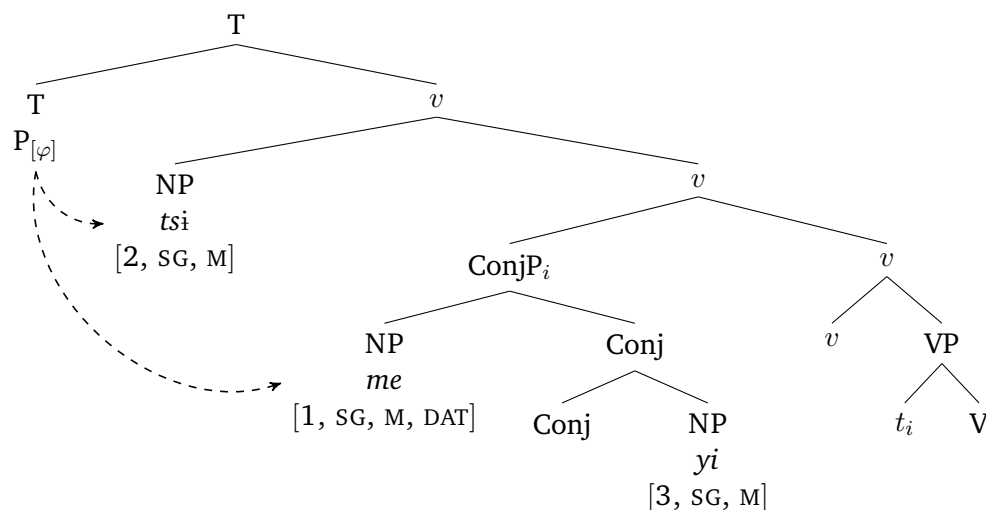

(130) *Output of Agree-Link*

In (118), the entire **ConjP** moves out of the **VP**, which moves the conjuncts into the same phase as the agreement probe. In this configuration, Multiple Agree can see the subject and crucially the first person object but not the third person object.<sup>17</sup> This follows from the Visibility Condition provided in (121). The features of the first conjunct are a superset of those of the subject, hence it is visible to the agreement probe. This establishes an Agree-Link relation between the probe and the first conjunct, which is then turned into DOM case via Agree-Case at PF. On the other hand, the features of the second conjunct are a proper subset of those of the subject as well as the features of the first conjunct. This hides the third person object from the agreement probe resulting in no agreement and no DOM eventually.<sup>18</sup>

The same analysis captures (128) as well. The only difference is the relevant positions of the two conjuncts. The relevant structure of (128) is provided below.

<sup>17</sup>The analysis here assumes that **ConjP** in Kashmiri does not have any  $\varphi$ -features. In languages where **ConjP** gets  $\varphi$ -features as a result of feature resolution, **ConjP** can be an intervener for Agreement relations. Such contexts create additional complexity with respect to the interaction  $\varphi$ -features, licensing, and DOM. I leave the investigation of such phenomena for future work.

<sup>18</sup>The analysis of asymmetric DOM proposed in this section also makes predictions regarding the interpretation of specificity. Given asymmetric DOM and movement of the entire **ConjP** out of the **VP**, specificity cannot be purely the result of movement. If it were, both of the conjuncts would have to be interpreted as specific. Instead, specific NPs are forced to move out of **VP**. As shown by Holmberg (1986) (Holmberg's Generalization), specific NPs move out of **VP** only if they can. This is why specificity is not always accompanied by movement out of **VP**. Similarly, not all the NPs that move out of **VP** are interpreted as specific.

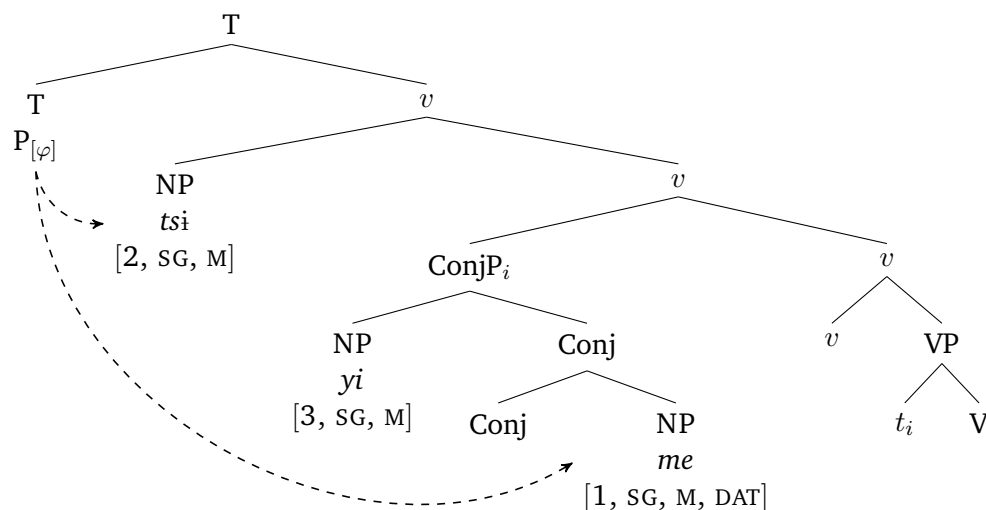
(131) *Output of Agree-Link*

In (131), the features of the first conjunct are a proper subset of the features of the subject. This hides the first conjunct from the agreement probe and results in no DOM on the first conjunct. The features of the second conjunct are a superset of the features of the subject, hence it is visible to the probe. Agree-Link establishes an agreement relation between the probe and the goal which is dereferenced by Agree-Case at PF.

#### 5.4 Previous analyses of Kashmiri DOM

The animacy hierarchy effects in Kashmiri have drawn the interest of Nichols (2001), Béjar and Rezac (2009), and Barány (2017) among others. In the following, I briefly discuss these approaches and compare my analysis to them.

Nichols (2001) adopts a static view of referential hierarchy where nominals are externally ranked based on their referentiality/animacy. She argues that person hierarchy phenomena arises as a result of a contradiction between two competing constraints given in (132).

(132) *Feature Hierarchy Constraint*

(Nichols 2001)

- a. Highest ranking argument (person/referential) feature associates to Tense.

- b. Nominative argument (person/referential) feature copies to Tense in spec-head agreement.

In this view, T can accommodate only one structural relationship. Nichols argues that (132-a) and (132-b) leads to a competition when the subject is not the highest ranking argument in the clause. In such cases, languages need to choose either (132-a) or (132-b) and resolve the need for the other constraint in some other way. She argues that in Kashmiri, (132-b) wins over (132-a). This means that the nominative argument must be associated with T via spec-head agreement and the remaining argument gets non-structural Dative case as a last resort. The non-structural Dative case in a sense “hides” the internal argument from T since an argument with non-structural case cannot establish any structural relation with T.

My analysis shares a similar intuition with Nichols’ analysis in that Differential Object Marking in Kashmiri arises as a result of a single probe with multiple goals. However, there are some significant differences. Unlike Nichols, I argue that the DOM marked argument establishes an Agree-Link relation with T. In addition, following Béjar and Rezac (2009) and Barány (2017), I adopt a non-static view of referential hierarchies.

Béjar and Rezac (2009) and Barány (2017) take a non-static approach to the hierarchy phenomena and derive the hierarchy effects in the syntax via agreement. Although they have some significant differences, they both derive hierarchy effects via Cyclic Agree (Béjar and Rezac 2009). In both approaches, the internal argument receives a special case (DOM) when the feature composition of the internal argument is a superset of the feature composition of the external argument. Under such circumstances, the external argument cannot value the probe on *v* since it has already been valued by a richer goal. Another probe is required to agree with the external argument. For Béjar and Rezac (2009), an optional extra probe is added in such cases and the addition of the extra probe leads to special Dative marking on the internal argument. In Barány’s account, *v* normally assigns Dative case to the internal argument when *v* only agrees with the internal argument. In configurations when the external argument has a richer feature structure than the internal argument, the *v*+T agrees with the external argument as well as the internal argument. Under such

circumstances, an impoverishment rule deletes the Dative case feature on *v* and the object is realized as nominative.

Both Bejar and Rezac, and Barany's accounts capture the differential object marking facts in Kashmiri while deriving the hierarchy effects in the syntax via agreement. The analysis I developed in this chapter adopts the subset/superset view of Béjar and Rezac (2009) and Barány (2017). It differs from both approaches in some significant ways though. I assume that there is only one agreement probe in Kashmiri and it is on T. T establishes Multiple Agree with both the external argument and the internal argument when both arguments are visible. Finally, I derive the hierarchy effects via the Visibility Condition in (127).

## 6 Back to Turkish and Hindi

So far, I have discussed Kashmiri DOM facts and proposed a licensing and agreement based analysis that captures these facts. I have also argued that Dependent Case cannot account for the person hierarchy effects in Kashmiri straightforwardly. In this section, I briefly discuss how Dependent Case accounts for Hindi and Turkish. In both Turkish and Hindi, asymmetric DOM is disallowed and DOM does not alternate across tenses or aspects. In both languages, there is some evidence indicating that specific objects move out of VP. In Turkish, this is supported by the adverb placement test as shown in (18) and (19). The examples are repeated below for convenience.

- (133) a. Ali sessizce kitap oku-du.  
 Ali quietly book read-PAST  
 'Ali quietly read (a) book.'
- b. \*Ali kitap sessizce okudu.  
 Ali book quietly read-PAST  
 'Ali quietly read (a) book.'
- (134) Ali kitab-ı sessizce okudu.  
 Ali book quietly read-PAST  
 'Ali quietly read the book.'

Adverb placement is not a good test in Hindi to show the relative position of specific objects since the adverbs seem not to have a fixed position (Bhatt and Anagnostopoulou 1996). Nevertheless, the relative position of the direct object with respect to the indirect object indicates that specific objects move out of VP.

(135) Ram-ne Anita-ko chitthii bhej-ii.  
 Ram-ERG Anita-KO letter.F send-PFV.F  
 'Ram sent a letter to Anita.' (Bhatt and Anagnostopoulou 1996)

(136) Ram-ne chitthii-ko Anita-ko bhej-aa.  
 Ram-ERG letter.F-KO Anita-KO send-PFV  
 'Ram sent the letter to Anita.' (Bhatt and Anagnostopoulou 1996)

When the specific object moves out of the VP, it moves into the same case domain (phase) as the external argument and satisfies the condition for Dependent Case being assigned. The Dependent Case rule below captures Differential Object Marking in both Turkish and Hindi.

(137) If NP1 c-commands NP2 when TP is spelled-out, assign NP2 DEPENDENT case.

The abstract structures of clauses with and without specific objects in Hindi and Turkish are given in (138) and (139).

## (138) DOM as Dependent Case

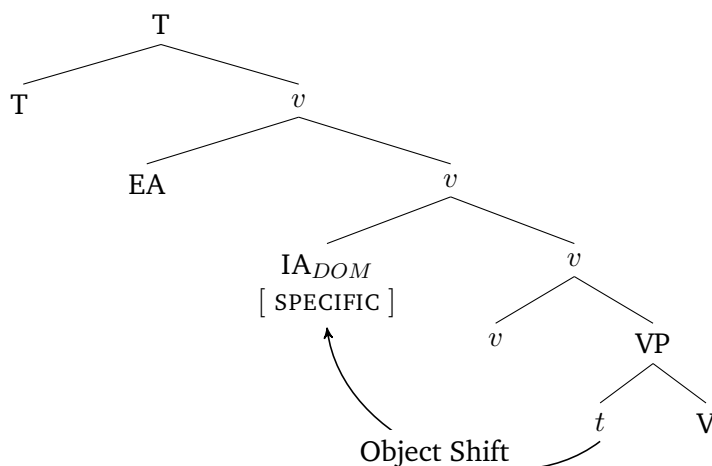

## (139) Dependent Case does not apply

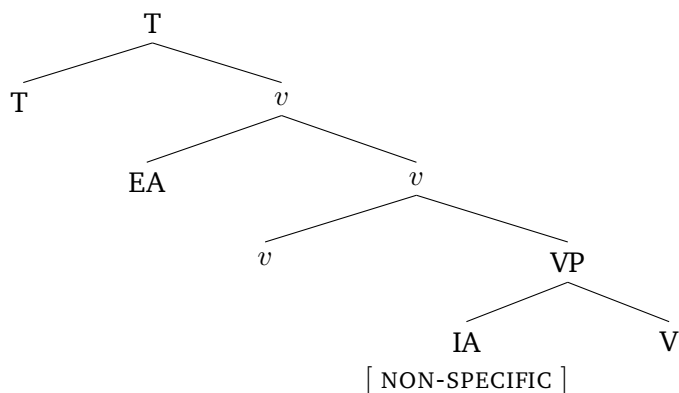

The abstract structures above illustrate how Dependent Case can account for DOM in Turkish and Hindi. Note that the Dependent Case view also accounts for the symmetric DOM in Hindi and Turkish. Given the Coordinate Structure Constraint, either both conjuncts must be moved together or they both remain in situ. In Turkish and Hindi, the symmetric DOM can be accounted for by the Dependent Case view and the trees below illustrate these structures.

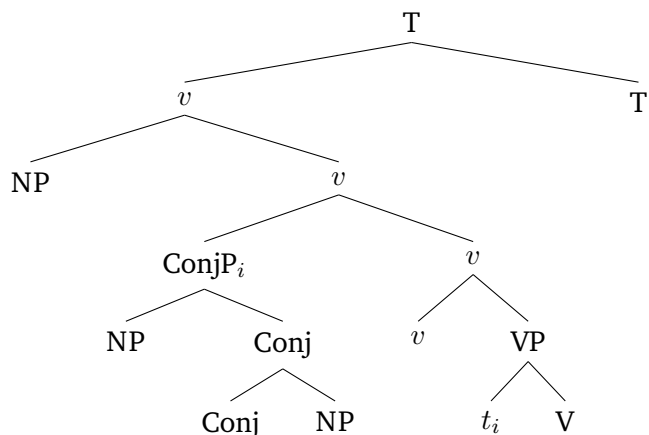
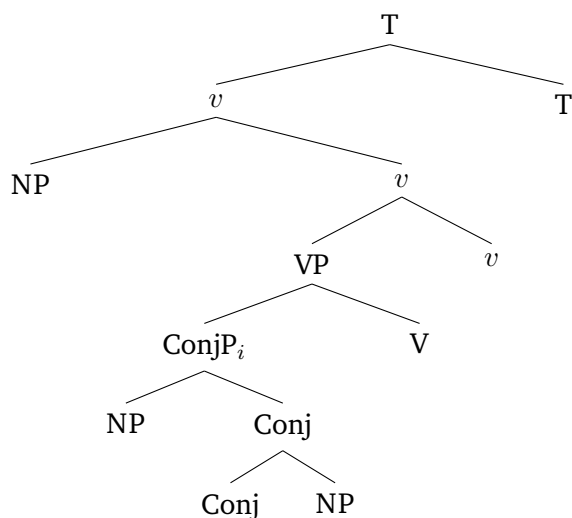
(140) *Symmetric DOM via Dependent Case*(141) *Symmetric No-DOM*

In (140) both conjuncts are moved out of the lower phase and either the entire ConjP gets Dependent Case or both of the NPs inside the ConjP get Dependent Case. On the other hand, in (141) the ConjP remains inside the lower phase and there is no Dependent Case assignment as the subject and the object are in different phases. Finally, structures like (142), in which only one of the conjuncts is moved are banned due to the Coordinate Structure Constraint.

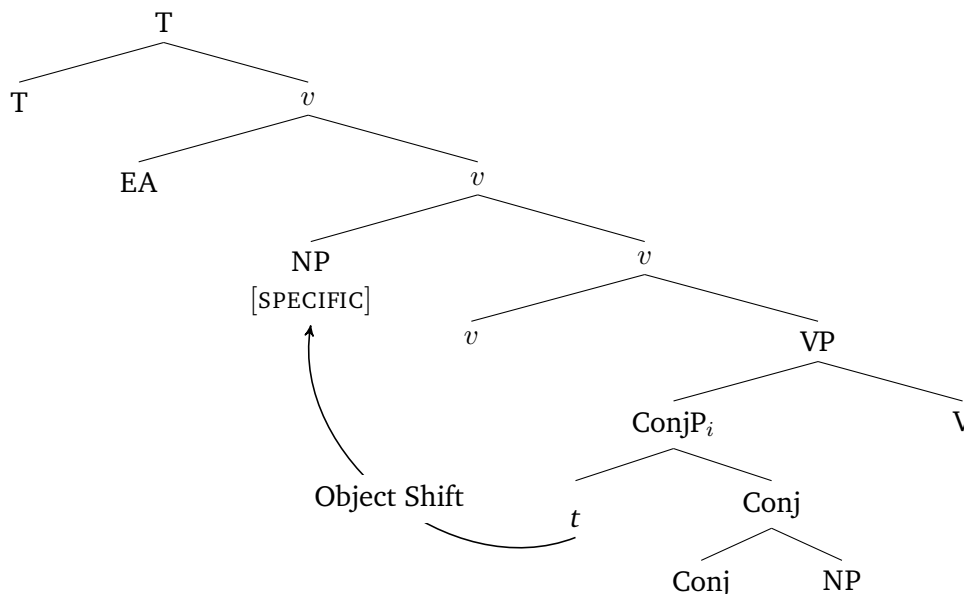
(142) *CSC Violation*

So far, in this section, I have shown how Dependent Case can account for DOM facts in Hindi and Turkish. Let me wrap up this section by discussing why a licensing framework cannot account for the facts in Turkish and Hindi. The key factor in DOM within the licensing framework is agreement. In Kashmiri (as well as in Senaya discussed in the next section), DOM correlates with agreement. If an object is agreed with and the agreement is realized overtly, then DOM is not observed. In the licensing framework proposed in this chapter, DOM occurs when an object is in the same domain as an agreement probe. A natural prediction of this theory is that the lack of agreement should also remove DOM.<sup>19</sup> In Turkish, DOM occurs in cases when the verb lacks agreement altogether. Consider the following infinitival structure.

- (143) Ali-yi gör-mek  
 Ali-ACC see-INF  
 'To see Ali'

In (143), the verb does not have any agreement because it is infinitival. Yet, there is still

<sup>19</sup>Note that PCC effects are absent in infinitival clauses without agreement probes. See (79). Since licensing driven DOM is (in some sense) a PCC repair mechanism, lack of an agreement probe should obviate the need for DOM.



Differential Object Marking on the internal argument *Ali*. This supports the claim that in Turkish, DOM is not about licensing. Instead, it is the result of Dependent Case.

There is some evidence from Hindi that supports the proposal that in Hindi, DOM is not about licensing. Consider the following examples from Chapter 2.

- (144) a. Raam-ne roṭii khyaayii thii.  
 Raam.MASC-ERG bread.FEM eat.PERF.FEM be.PAST.FEM  
 ‘Ram had eaten bread.’ (Mahajan 1990a, p. 73)
- b. Siita-ne larkii-ko dekhaa.  
 Siita.FEM-ERG girl.FEM-ACC see.PERF.MASC  
 ‘Sita saw the girl.’ (Bobaljik 2008)

The clauses in (144) are in perfective aspect. The subjects are ergative and the objects vary in terms of their case due to Differential Object Marking. In (144-a), the object is non-specific and is caseless. The verb agrees with the object in gender. On the other hand, in (144-b), the object is specific and receives DOM case (*ko*) and the verb shows default masculine agreement. If DOM in Hindi were about licensing, then we would expect no difference in the two clauses above in terms of case on objects and agreement with them. More specifically, if DOM were about licensing through agreement, we would expect gender agreement between the verb and the object since the agreement probe is available in both clauses. If DOM case were due to agreement with the object, then we would expect DOM on (144-a) or no DOM on (144-b).<sup>20</sup> It should be noted that Hindi and Kashmiri are both split-ergative languages. While DOM is lost in Kashmiri ergative clauses, it is maintained in Hindi indicating a difference in the nature of DOM in these two languages.

Before closing this section, let me add a final remark about the lack of agreement with DOM marked objects in Hindi. In (144-b), the object is marked with *ko* and the verb does not show overt gender agreement with it while there is overt gender agreement with the caseless object in (144-a). This is automatically accounted for by one of the earlier assumptions I made in Chapter 2. The assumption was that Agree-Link happens after Lexical and

<sup>20</sup>Note that the licensing approaches that postulate added probes (like Kalin (2018)) are non-starters because there is already an agreement probe in the right position for agreement to happen. The added probe theories propose that DOM is the result of licensing through agreement with added probes. In (144), there is already a probe that can agree with the object. If DOM case were the result of agreement with a probe, then we would expect DOM in (144-a) and overt agreement in (144-b). Neither is attested.

Dependent Case assignment. In Hindi, DOM is assigned through Dependent Case which blocks overt agreement with *ko*-marked objects. This is in line with the analysis of Hindi agreement facts discussed in Chapter 2.

## 7 Extending the Analysis to Senaya

The Feature Licensing Condition developed in this chapter makes clear predictions regarding the distribution of nominals that have some marked features. Markedness is language specific and languages can choose different features as “marked”. For example, in Turkish specific nominals are marked while in Hebrew markedness is about definiteness. The Feature Licensing Condition requires that a marked noun be agreed with when it occurs in the same agreement domain as an agreement probe. In particular, an Agree-Link relation must be established between the agreement probe and the marked nominal. This Agree-Link relationship can be transduced by two distinct operations at PF, Agree-Copy, which results in overt agreement, and Agree-Case, which yields DOM. I have argued that in languages where DOM is related to Tense/Aspect/Agreement, Differential Object Marking realized as overt case is the overt realiation of Agree-Case which applies after Agree-Copy and transduces the Agree-Link Relations into DOM case by dereferencing the pointers on the probe. Unresolved Agree-Link relations (pointers on probes) cause problems for PF interpretation as there is no Vocabulary Item to realize the structure. This theory predicts that if a language lacks Agree-Case (or case marking in general), then such marked nominals will lead to an interpretation problem at PF and lead to ungrammaticality, i.e. ineffable combinations. In this section, I present some evidence from Senaya that confirms these predictions.

Senaya (ISO 639-3: [syn]) is a Neo-Aramaic language spoken in the city of Sanandaj, Iran. The Senaya data discussed in this section come from Kalin (2018) and Kalin and van Urk (2015). Like Kashmiri, Senaya is an aspect based split ergative language. Unlike Kashmiri, Senaya nominals are morphologically unmarked for case and its split ergativity is realized as agreement patterns. In imperfective clauses, subjects are always agreed with while objects are agreed with only when they are specific. In imperfective clauses, subjects

are indexed on the verb with a series of suffixes called S-suffixes while objects are cross-referenced with L-suffixes. S and L-suffixes refer to two different morphological paradigms. In imperfective clauses, they can both be used in the same clause. In perfective clauses, only L-suffixes are used. Specificity related agreement patterns in imperfective clauses are shown in (145) and (146).

- (145)     $\bar{A}$ na (xa) ksūta xazy-an- $\bar{a}$ .  
 I    a    book.F see.IMPF-S.1SG-L.3FS  
 ‘I see a (specific) book (e.g. on the table).’  
 (Object is specific, indefinite.)

- (146)     $\bar{A}$ na (xa) ksūta kasw-an.  
 I    a    book.F write.IMPF-S.1SG  
 ‘I will write a book (e.g., someday, about something, I dont know what).’  
 (Object is nonspecific, indefinite.)

In (145), the object *ksūta* ‘book’ is specific and it triggers agreement on the verb, realized with an L-suffix *-ā* ‘3FS’. In addition, the verb also agrees with the subject. Subject agreement is expounded with the S-suffix *-an* ‘1SG’. In contrast, in (146), the object *ksūta* ‘book’ is interpreted as non-specific and the verb does not show agreement with the object. However, the subject agreement is still in place and unchanged. Just like in (145), the subject is cross-referenced with the S-suffix *-an* ‘1SG’. In Senaya imperfective clauses, DOM is expressed in the form of presence vs. absence of overt agreement with objects. Specific objects trigger overt agreement while there is no visible agreement with non-specific objects.

In perfective clauses, only subjects are agreed with while objects are never agreed with. When subjects are cross-referenced on the verb, unlike in the imperfective clauses, L-suffixes are used.

- (147)     $\bar{A}$ yēt ksū-wā-lox.  
 You write.PFV-PST-L.2MS  
 ‘You wrote (a long time ago).’  
 (Subject is agentive, specific, definite, animate.)

What is striking about Senaya is that specific objects are disallowed in perfective clauses as shown in (148).<sup>21</sup>

- (148) \*Axnī ō ksūta ksū-lan.  
 we that book.F write.PFV-L.1PL  
 Intended: ‘We wrote that book.’

The Senaya data in (145)-(146) presents a case of differential object marking involving agreement in imperfective clauses. Only specific objects are agreed with while non-specific objects are not agreed with. In addition, the data in (147)-(148) presents a puzzle in which specific objects are banned in perfective clauses. One needs a theory of nominal licensing that can account for the differential marking in the imperfective clauses and the ungrammaticality of specific objects in (non-periphrastic) perfective clauses.

The licensing framework developed in this chapter accounts for both the differential object marking (involving agreement) and the ungrammaticality of (148). First, let me briefly comment on why a licensing approach to DOM in Senaya is suitable. In Section 1.2, I compared Hindi, Turkish, and Kashmiri with respect to three criteria. These criteria were, i) is the DOM case structural? ii) is asymmetric DOM available? and iii) does DOM vary across tenses? The first criterion cannot be applied as Senaya does not have (overt) case. As for the second criterion, unfortunately, I do not have access to data to test asymmetric DOM in Senaya. However, there is data that bears on the third criterion. As shown in (145) through (148), differential object marking and the availability of specific objects correlates with Aspect like in Kashmiri. I take this to be an indicator of the nature of DOM in Senaya. In particular, I propose that the Feature Licensing Constraint and the two-step Agree model developed in this chapter can account for the Senaya facts.<sup>22</sup> In the following, I briefly discuss Kalin and van Urk’s (2015) analysis of the agreement split in Senaya, which serves

<sup>21</sup>In Senaya, expressing specificity on objects in perfective clauses is done periphrastically. The periphrastic form uses an imperfective verb base. This is shown in (i).

- (i) Āna (xa) ksūta tem-xazy-an-ā.  
 I a book.F PFV-see.IMPF-S.1SG-L.3FS  
 ‘I saw a (specific) book (e.g. on the table).’ (Kalin 2018)

<sup>22</sup>For an alternative licensing-based analysis see Kalin (2018).

as the basis for my analysis of the data in (147)-(148).

Kalin and van Urk (2015) analyze the agreement patterns in Senaya as *agreement reversal*. Agreement reversal refers to the agreement patterns observed in imperfective clauses versus perfective clauses in Senaya. In imperfective clauses, subject agreement is marked with S-suffixes while agreement with specific objects is marked with L-suffixes. In perfective clauses, agreement with subjects is marked with L-suffixes and there is no object agreement. Kalin and van Urk (2015) analyze this agreement reversal as a case of split ergativity in agreement. They argue that the difference between the agreement patterns in the two aspects is due to the existence of an extra agreement probe available in imperfective clauses but not in perfective clauses. The tree in (149) represents the structure of an imperfective clause in Senaya while (150) represents a perfective clause.

(149) Imperfective Transitive

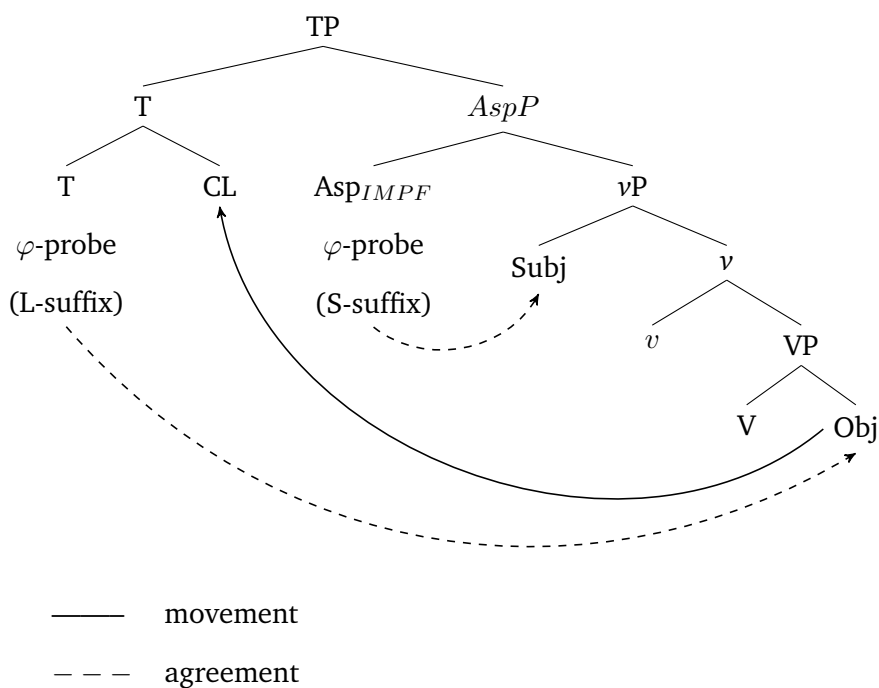

## (150) Perfective Transitive

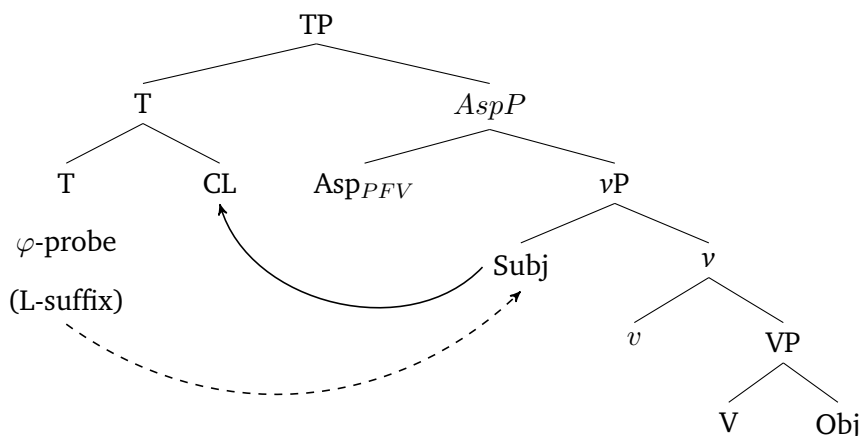

In (149), which is the structure of an imperfective transitive clause in Senaya, the Asp head comes with a  $\varphi$ -probe that agrees with the subject, which is the closest nominal in its c-command domain. The agreement on Asp is realized with S-suffixes. The  $\varphi$ -probe on T agrees with the object as the subject is already agreed with. Once the agreement is established, the object clitic moves and adjoins to T. The agreement on T is realized with L-suffixes. In perfective clauses, represented by (150), Asp does not come with a  $\varphi$ -probe. The only probe in the clause is on T. When T probes down, the closest nominal it finds is the subject. T agrees with the subject and the subject clitic moves to adjoint to T. The agreement between the subject and T is realized with L-suffixes. This explains why subject agreement is realized with S-suffixes in imperfective clauses but with L-suffixes in perfective clauses. It also explains why objects are never agreed with in perfective clauses.

While the analysis provided by Kalin and van Urk (2015) accounts for the agreement reversal facts in Senaya, it does not account for the lack of agreement with non-specific objects in imperfective clauses; nor does it explain the ungrammaticality of specific objects in perfective clauses as in (148). Kalin (2018) observes the DOM facts in Senaya and provides an analysis based on optional added probes. In the following, I argue that the Feature Licensing Condition approach developed in this chapter accounts for both the lack of agreement with non-specific objects in imperfective clauses and the ungrammaticality of specific objects in perfective clauses.

The licensing framework I proposed in this chapter is based on a standard assumption regarding specific NPs moving out of the VP following Diesing (1992), Bhatt and Anagnostopoulou (1996), and Torrego (1998). In a phase based syntax, one of the main positions for a specific NP to move to is the specifier position of *v*P. As the external argument is already introduced in Spec, *v*P, the internal argument can conceivably either merge above the external argument or tuck-in (Richards 1997) below the external argument. Given the word order (SOV) and agreement facts, I claim that the specific objects move to Spec, *v*P and tuck-in below the external argument. This accounts for the agreement with specific objects. (151) shows the derivation of an imperfective clause with a specific object.<sup>23</sup>

(151) Agreement with Specific Objects in Senaya

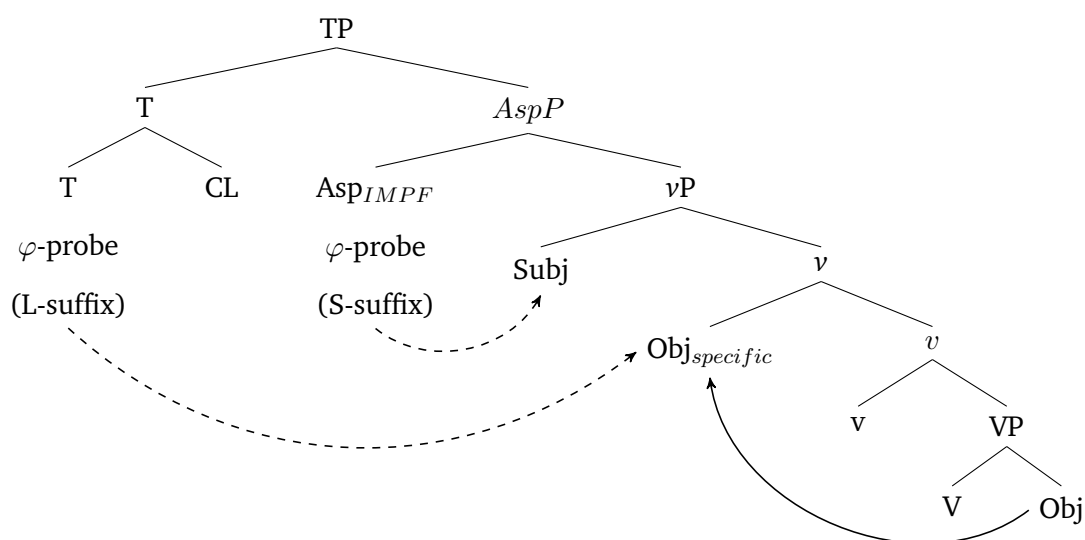

In (151), the specific NP object moves outside the lower phase and into the agreement domain where there are two  $\varphi$ -probes. The Feature Licensing Condition requires it to be licensed through agreement as it is specific and is in the same domain as an agreement probe. In this configuration both the subject and the object NPs are licensed via agreement with a  $\varphi$ -probe.

In cases when the object is non-specific, it stays inside the *v*P phase and this makes it

<sup>23</sup> The clitic movement isn't displayed so as not to clutter the tree diagram. The noun phrase that T agrees with is clitic doubled and the clitic moves to adjoin T.

impossible for T to agree with the object as it is invisible due to the Phase Impenetrability Condition. The structure for an imperfective clause with a non-specific nominal is given in (152).

(152) Lack of Agreement with Non-specific Objects in Senaya

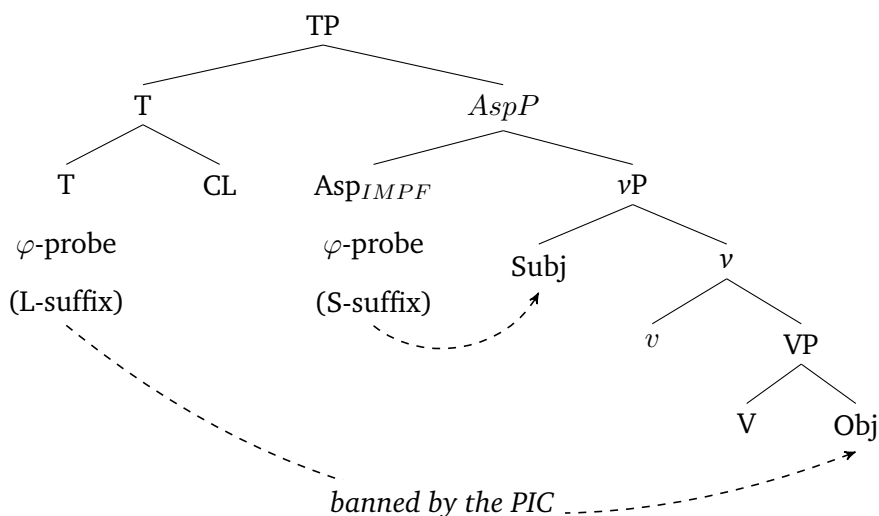

As T cannot agree with the internal argument due to the PIC, we only get S-suffix agreement on the verb when the object is non-specific in imperfective clauses.<sup>24</sup>

So far, I have provided an account of differential object marking realized as agreement in Senaya adopting Kalin and van Urk's analysis of agreement reversal. The only significant difference between my proposal and theirs is that I have followed the standard assumption about *v* being the phase head, while Kalin and van Urk assume Asp to be the lower phase head in Senaya but not *v*. Next, let me provide an account of the more surprising fact about Senaya that perfective clauses do not allow specific NPs, as shown in (148).

The main difference between imperfective clauses and perfective clauses, as discussed by Kalin and van Urk (2015), is the lack of a  $\varphi$ -probe on Asp in perfective clauses. Keeping all the other assumptions constant, the structure of a perfective clause with a specific object would be as in (153).

<sup>24</sup> It should be noted that the lack of agreement on T does not cause ungrammaticality as I assume that agreement is a fallible operation that needs to be applied but can still fail without causing any ungrammaticality. See Preminger (2014) for details.



(153) Perfective clause with a specific object

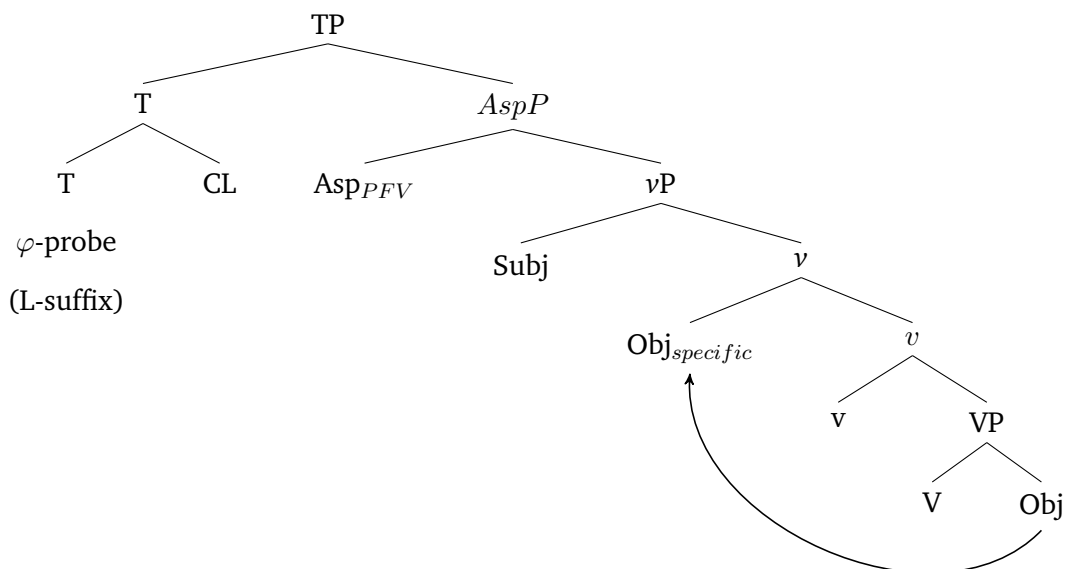

In this configuration, the Feature Licensing Condition enforces Multiple Agree because the specific object is in the same agreement domain as an agreement probe. The probe establishes two Agree-Link relations one with the subject and one with the object as in (154).

(154) Output of Agree-Link

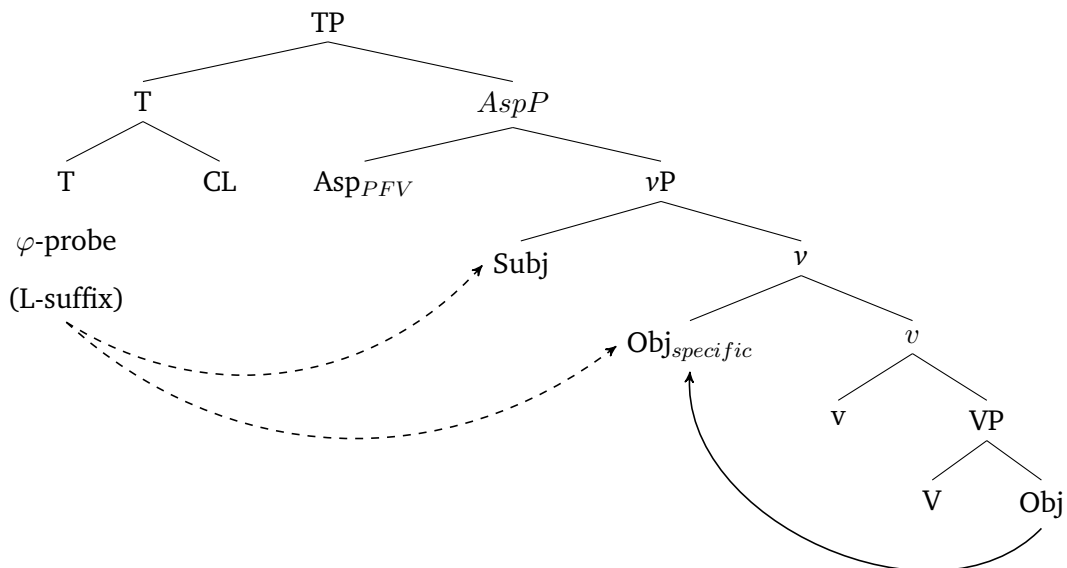

When the structure above is fed into Agree-Copy, the first Agree-Link (between the subject and the probe) is dereferenced but the second one cannot be and the output of Agree-Copy is as in (155).

(155) Output of Agree-Copy

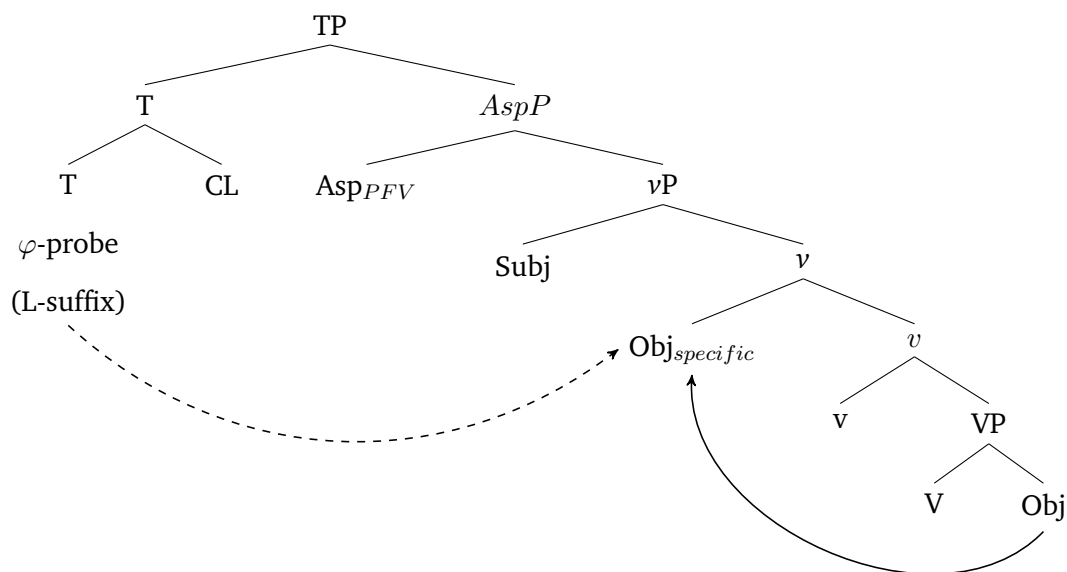

In this configuration, the probe still has one pointer that has not been dereferenced. Since Senaya does not have Agree-Case (it does not have case in general), the pointer can never be dereferenced and this causes a problem at Vocabulary Insertion. This accounts for the ban on specific objects in perfective clauses.

To sum up, in this section, I have shown that the DOM analysis developed for Kashmiri extends to Senaya, a language that lacks case marking and has a Differential Object Marking mechanism that is manifested via verbal agreement. I have argued that the restriction of object agreement to specific objects in imperfective clauses is due to object shift. Specific objects move out of VP and they can be agreed with whereas non-specific objects remain inside the VP and agreement is banned due to the PIC. I have also argued that the ban on specific objects in past tense clauses is due to unresolved pointers at PF. Since Senaya lacks Agree-Case, pointers that are unresolved by Agree-Copy remain on the probe yielding a PF interpretability issue.

## 8 Chapter Summary

This chapter investigated the interaction between agreement and case by analyzing Differential Object Marking across four languages, Turkish, Hindi, Kashmiri, and Senaya. I have shown that DOM in Kashmiri has some significant differences from DOM in Hindi and Turkish. I argued that DOM in Hindi and Turkish are outputs of Dependent Accusative Case whereas DOM in Kashmiri is the realization of Agree-Case, an operation that turns Agree-Link relations into case marking on the goal. I have also claimed that unresolved Agree-Link relations cause interpretability issues at PF and result in ungrammaticality. One of the key components of the DOM analysis developed for Kashmiri was the licensing of marked features. I have argued that DOM in Kashmiri arises as a result of the licensing requirements on nominals with marked discourse status (animate nouns in Kashmiri) and it shows significant parallelisms with the PCC effects and PCC repairs.

## 5

**CONCLUSION**

In this dissertation, I have argued that agreement and case are surface realizations of several distinct operations distributed across the syntactic and morphological modules of the grammar. These operations can be grouped together as *agreement operations* ((1)) and *case operations* ((2)). Phenomena like *Case Sensitivity* and *Differential Object Marking* arise as a result of the interactions among agreement operations and case operations as well as other morpho-syntactic operations that induce movement or fusion ((3)).

(1) *Agreement Operations*

- a. Agree-Link
- b. Agree-Copy

(2) *Case Operations*

- a. Lexical Case
- b. Dependent Case
- c. Agree-Case

(3) *Other Operations*

- a. (Internal) Merge
- b. Fusion

Adopting an operation-based derivational grammar, I have argued that the operations listed in (1) - (3) are ordered as in (4).

(4) *Order of Operations*

$$\underbrace{\text{Lexical Case} \prec \text{Dep. Case} \prec \text{Agree-Link}}_{\textit{Syntax}} \prec \underbrace{\text{Fusion} \prec \text{Agree-Copy} \prec \text{Agree-Case}}_{\textit{Morphology}}$$

Each operation takes the output of the preceding operation and generates an output that is taken as input by the next operation. I assume these operations to form a universally available set from which languages can draw a particular subset. This is one of the main sources of cross-linguistic variation. For example, in the clausal domain, Kashmiri uses Lexical Case for assigning ergative case while Kurmanji uses Dependent Case. In contrast, Senaya does not use any case mechanisms at all. Another source of variation is due to parameterization of each operation. For example, Agree-Link can be parameterized for Single Agree or Multiple Agree. Similarly, Dependent Case can be parameterized to assign accusative or ergative (Baker 2015; Marantz 1991). Yet another source of cross-linguistic variation is due to properties of lexical items across languages (Borer-Chomsky conjecture). I have argued that agreement probes can be highly specified or remain underspecified. Based on these three main sources of variation, I have analyzed Case Sensitivity and Differential Object Marking across eight languages. In the following, I provide a summary of the main findings and claims and then discuss some remaining issues.

## 1 Summary of Main Findings

The first part of the dissertation focused on the interaction of case and agreement through Case Sensitivity. Building on Relativized Probing of Nevins (2011) and Preminger (2014), I have argued that Case Sensitivity is a matter of Relativized Minimality (Rizzi 1990). When the agreement probe is specified for a [+N] feature, Lexical and Dependent cases become interveners resulting in total or partial disruption of overt agreement between a probe and a nominal. In contrast, when the agreement probe is highly specified for PERSON, NUMBER, and GENDER features, it can skip over any irrelevant head/phrase including the KP as long as the probe and the potential goal are in the same phase.

In Chapter 2, I analyzed four languages – Hindi, Kurmanji, Faroese, and Icelandic –, where agreement is sensitive to overt case marking on nominals. I have argued that the agreement probe in these languages is specified for the nominal feature [+N]. The nominal feature is introduced by the head noun and it is copied on every head in the nominal spine through the extended projection (Grimshaw 1991) of a nominal. Assuming that Lexical and Dependent cases are K heads projecting a KP (Bittner and Hale 1996; Lamontagne and Travis 1986), KP becomes an intervener between an agreement probe and the  $\varphi$ -features under the KP. In other words, when the agreement probe is specified for [+N], it establishes an Agree-Link relation with the KP. When Agree-Copy applies, it attempts to copy the  $\varphi$ -features from the KP to the probe but it returns an empty set since the K head and its projection K phrase do not have any interpretable  $\varphi$ -features. This results in lack of surface agreement between a probe and an overtly case marked nominal in these languages. This account primarily captures Hindi, where the case morphemes do not carry any interpretable  $\varphi$ -features.

One of the predictions of the theory is that if KPs have  $\varphi$ -features, these features can be transferred to the probe by Agree-Copy. Otherwise, overt agreement is absent. Supporting evidence for the proposal that KPs are interveners and they are agreed with in the syntax comes from Kurmanji, Faroese, and Icelandic. In these languages, overtly case marked nominals (oblique and dative) usually block surface agreement. I have shown that in these languages, fusion of plural morpheme with the case morpheme makes number agreement with an overtly case marked nominal possible. In Kurmanji, oblique K and number fuse into a single morpheme and this makes number agreement with an oblique nominal possible. On the other hand, K does not fuse with any  $\varphi$ -features in first and second person pronouns and this results in the lack of surface agreement with an oblique first or second person pronoun. Faroese is similar to Kurmanji whereas Icelandic has some further complexities addressed in Chapter 2.

The second part of the dissertation focused on the interaction of agreement and case through Differential Object Marking (DOM). Comparing three languages with DOM, Turkish, Hindi, and Kashmiri, I have argued that the DOM in Kashmiri is significantly different from the DOM in Turkish and Hindi because it varies across aspects, it is subject to animacy hierarchy effects, and it allows asymmetric DOM. I have argued that the DOM in Turkish and Hindi is due to Dependent Case assignment while in Kashmiri it is a result of *nominal licensing* via Agree-Link. Adopting a licensing view of DOM (Barány 2017; Béjar and Rezac 2009; Kalin 2018; Levin 2018; van Urk to appear) and extending Preminger's (2011) Person Licensing Condition, I proposed that marked nominals need licensing via agreement when they are visible to an agreement probe. This is stated as Feature Licensing Condition in (5).

(5) *Feature Licensing Condition*

A nominal N with a feature F ( $N_{[F]}$ ) must enter an agreement relation with a probe P with a matching F ( $P_{[F]}$ ) if N is visible to P.

The feature licensing condition leads to Person Case Constraint (PCC) like effects when there is only one agreement probe in a phase and it has two visible potential goals. This configuration is given in (6).

(6) PCC/DOM Configuration

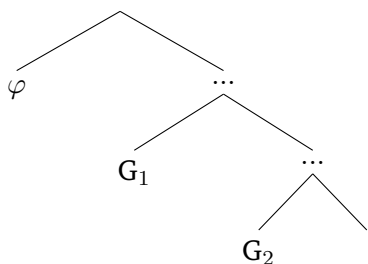

In this configuration, the Feature Licensing Condition requires Multiple Agree-Link relations between the probe and the two goals. This results in two Agree-Link relations (pointers). I have argued that Agree-Link relations can be resolved by Agree-Copy as overt agreement on the probe or Agree-Case as overt case on the goal. In languages where Agree-Case is employed, Agree-Case applies after Agree-Copy and resolves the remaining Agree-Link relations. This is realized as Differential Object Marking or a PCC repair by Case (see Rezac (2010)). I have also argued that unresolved Agree-Link relations cause a ungrammaticality at PF yielding ineffability of certain structures. This captures the ungrammaticality of specific objects in Senaya perfective clauses and can be extended to other languages like Akan with similar restrictions.

## **2 Remaining Issues**

There are a number of issues that are raised by the main proposals of the dissertation, which I did not cover in this dissertation. In the following, I briefly discuss some of these issues to lay groundwork for future research.

### **2.1 Ordering the Proposed Operations**

One of the major claims of this dissertation has been about the ordering of agreement and case related operations. I have argued that the order of operations in (4) accounts for variation in Case Sensitivity and Differential Object Marking in a range of languages. One immediate question raised by this ordering argument is whether the order in (4) is universal or subject to variation. Arguing that the order in (4) is universal with such a small sample of languages would be naive at best. It is quite possible that the order in (4) is not universal and it is subject to variation. In fact, Marušič, Nevins, and Badecker (2015) argue that Agree-Copy can apply before or after Conjunct-Flattening, an operation that flattens the hierarchical structure in a conjunction at PF. A similar proposal can potentially account for languages like Nepali where overt case does not block agreement while there is no evidence for highly specified probes. It could be argued that, in Nepali, Agree-Link applies before any case assigning operation applies. Obviously, such an account can be extended



to Turkish and Laz, which requires an overhaul of Chapter 3 of this dissertation. A similar proposal about the ordering of syntactic and morphological operations has been made by Keine (2010), who argues that Agree and Impoverishment apply in the same module of grammar and they can apply without any extrinsic ordering. Agree can feed Impoverishment and Impoverishment can feed Agree.

In principle, any permutation of the operations listed in (1) - (3) should be possible. A free ordering of these 7 operations yields 5040 possible permutations.<sup>1</sup> While a mathematical possibility, this overgenerates massively. Luckily, there are certain theoretical and logical constraints that restrict the number of possible permutations significantly. Certain orders are vacuous and they do not make any sense. For example, Agree-Copy or Agree-Case cannot apply before Agree-Link as they both operate on the output of Agree-Link. Theoretically, the operations listed in (1) - (3) belong to two distinct components of the grammar, which rules out a significant number of possible orders. Leaving aside Merge, there are 3 syntactic operations and 3 morphological operations. This reduces the number of possible combinations to 36 (6 in the syntax and 6 in the morphology). While 36 is a significantly low number compared to 5040, it is still too large, especially when other morpho-syntactic operations not listed here are taken into consideration. Allowing a reordering of operations has the potential to overgenerate massively and requires empirical justification.

Although reordering of operations can potentially overgenerate, the modular organization of these operations reduces the number of overall combinations and has the potential to capture cross-linguistic variation in a principled way. Arregi and Nevins (2012) develop a modular architecture where a large number of syntactic, morphological, and phonological operations are ordered with respect to each other across several sub-modules of morphology and phonology in a principled way. A principled theory of ordering operations can capture more cross-linguistic variation without overgenerating massively. I believe that pursuing the line of research outlined by Arregi and Nevins (2012) can capture more cross-linguistic variation while shedding light into the modular structure of the grammar. I leave the investigation of variation in the order of operations for future work.

---

<sup>1</sup>The number of possible permutations is reduced to 720 when Merge is excluded. Yet, the number grows factorially with any other operation, e.g. Fission, Impoverishment, etc..

Another relevant question about the operations listed in (1) - (3) is about the number of times each operation can apply in a grammatical cycle, where a grammatical cycle can be roughly defined as a phase with the cautionary note that cycles in different modules of the grammar may not be the same in their size or content. Obviously, Chomsky's Merge operation is unbounded and applies multiple times in a phase. At a minimum, it applies  $n - 1$  times, where  $n$  is the number of syntactic terminals in a given phase. In Chapter 4, I have argued that Agree-Copy can apply multiple times either until all the Agree-Link relations are resolved or until the agreement probe can no longer host any more  $\varphi$ -values, whichever comes first. One question that remains to be solved is the restrictions on the number of times each operation can apply and what triggers each of these operations.

## 2.2 Interacting with other operations

One of the main findings of the dissertation is the fact that in some languages overt case marking blocks agreement only partially. For example, in Kurmanji third person oblique subjects can be agreed with in number while first and second person oblique objects cannot be agreed with at all.<sup>2</sup> I have argued that third person oblique subjects can be agreed with thanks to the fusion of number and case in those nominals. In other words, I have argued that Fusion feeds Agree-Copy. One relevant question is whether other operations can feed or bleed Agree-Copy. For example, can deletion of an goal with which a probe has established an Agree-Link relation bleed Agree-Copy?

There is some evidence from Kurmanji that indicates that this is a possibility. In Kurmanji past tense clauses, first and second person pronoun objects are agreed with in person and number as in (7).

- (7) Mehemed-e ez di-m.  
 Mehemed-OBL 1SG.DIR saw-1SG  
 'Mehemed saw me.'

In configurations where two clauses are coordinated for contrast, the second object can be null. Under such circumstances, the agreement on the second verb is lost as in (8). More

<sup>2</sup>"agreed with" here means shows overt agreement.

importantly, agreement on the second object leads to ungrammaticality as in (9).

- (8) Mehemed-e ez di-m hema Eşxan-e ne-di.  
 Mehemed-OBL 1SG.DIR saw-1SG but Eşxan-OBL NEG-saw  
 ‘Mehemed saw me but Esxan didn’t.’
- (9) \*Mehemed-e ez di-m hema Eşxan-e ne-di-m.  
 Mehemed-OBL 1SG.DIR saw-1SG but Eşxan-OBL NEG-saw-1sg  
 ‘Mehemed saw me but Esxan didn’t.’

While it would be premature to make any claims about the structure of these clauses and argue that certain deletion operations can bleed Agree-Copy, there is a possibility that such a claim would be true. Further research is needed to account for the interaction of agreement and null objects like in (8) and(9).

### 3 Final Remarks

Cross-linguistic variation in agreement, case, and their interaction is massive and there is much more to say in these topics. I hope to have contributed to the topic by identifying some rare case and agreement patterns like partial agreement and accounting for a range of different agreement and case related phenomena with a theory of agreement and case related operations distributed across different modules of the grammar in a specific order.

## BIBLIOGRAPHY

- Adams, Ernest W (1970). Subjunctive and indicative conditionals. In: *Foundations of language*, pp. 89–94.
- Aissen, Judith (2003). Differential object marking: Iconicity vs. economy. In: *Natural Language & Linguistic Theory* 21.3, pp. 435–483.
- Akkuş, Faruk (to appear). On Iranian Case and Agreement. In: *Natural Language & Linguistic Theory*.
- Anderson, Stephen R (1992). *A-Morphous Morphology*. Cambridge University Press.
- Arregi, Karlos and Andrew Nevins (2012). *Morphotactics: Basque auxiliaries and the structure of spellout*. Vol. 86. Springer Science & Business Media.
- Atlamaz, Ümit (2012). Ergative as Accusative Case: Evidence from Adıyaman Kurmanji. MA thesis. Boğaziçi University.
- (2013). Cyclic Agreement and Empty Slots in Pazar Laz. In: *Proceedings of the 37th Annual Meeting of the Berkeley Linguistics Society: Special Session on Languages of the Caucasus*. Ed. by Chundra Cathcart, Shinae Kang, and Clare Sandy, pp. 18–31.
- Atlamaz, Ümit and Mark C Baker (2016). On Agreement With and Past Oblique Subjects: New Considerations Based on Kurmanji. In: *Proceedings of the 46th annual meeting of the North East Linguistics Society*. Ed. by Christopher Kimmerly and Brandon Prickett. Vol. 1. Amherst, MA: GLSA Publications, pp. 39–49.
- Atlamaz, Ümit and Mark C Baker (2018). On Partial Agreement and Oblique Case. In: *Syntax* 21.3, pp. 195–237.
- Aygen, Gülşat (2002). Finiteness, Case and Clausal Architecture. PhD thesis. Harvard University.
- Baker, Mark and Nadezda Vinokurova (2010). *On tense and copular verbs in nonverbal predications in Sakha*. Tech. rep. Rutgers University.
- Baker, Mark C (1996). *The polysynthesis parameter*. Oxford University Press.
- (2003). *Lexical categories: Verbs, nouns and adjectives*. Vol. 102. Cambridge University Press.
- (2008). *The Syntax of Agreement and Concord*. Cambridge University Press.
- (2010). Formal Generative Typology. In: *The Oxford Handbook of Linguistic Analysis*. Ed. by Bernd Heine and Heiko Narrog. Oxford University Press, pp. 285–312.
- (2011). When agreement is for number and gender but not person. In: *Natural Language & Linguistic Theory* 29.4, pp. 875–915.
- (2015). *Case: Its Principles and its Parameters*. Cambridge University Press.
- (forthcoming). On Dependent Case and the Sometimes Independence of Ergativity and Differential Object Marking.
- Baker, Mark C and Ümit Atlamaz (2014). On the Relationship of Case to Agreement in Split-Ergative Kurmanji and Beyond. URL: <http://www.rci.rutgers.edu/~mabaker/kurmanji-split-erg-distributed-July-2014.pdf>.

- Baker, Mark C and Jim McCloskey (2007). On the relationship of typology to theoretical syntax. In: *Linguistic Typology* 11.1, pp. 285–296.
- Barány, András (2017). *Person, case, and agreement: The morphosyntax of inverse agreement and global case splits*. Oxford University Press.
- Béjar, Susana and Milan Rezac (2003). Person licensing and the derivation of PCC effects. In: *Amsterdam Studies In The Theory And History Of Linguistic Science Series 4*, pp. 49–62.
- (2009). Cyclic Agree. In: *Linguistic Inquiry* 40.1, pp. 35–73.
- Bhatt, Rajesh (2005). Long Distance Agreement in Hindi-Urdu. In: *Natural Language & Linguistic Theory* 23.4, pp. 757–807.
- (2007a). *Ergativity in Indo-Aryan Languages*. Ergativity Seminar MIT.
- (2007b). *Unaccusativity and Case Licensing*. Handout. McGill University.
- Bhatt, Rajesh and Elena Anagnostopoulou (1996). Object shift and specificity: Evidence from ko-phrases in Hindi. In: *Papers from the 32nd Regional Meeting of the Chicago Linguistics Society, Chicago Linguistics Society, Chicago*. Vol. 1122.
- Bhatt, Rajesh and Martin Walkow (2013). Locating Agreement in Grammar: An Argument from Agreement in Conjunctions. In: *Natural Language & Linguistic Theory* 31.4, pp. 951–1013.
- Bhatt, Rakesh Mohan (2013). *Verb movement and the syntax of Kashmiri*. Vol. 46. Springer Science & Business Media.
- Bittner, Maria and Ken Hale (1996). The Structural Determination of Case and Agreement. In: *Linguistic inquiry*, pp. 1–68.
- Bobaljik, Jonathan (2008). Where is Phi. In: *Phi Theory: Phi-Features Across Modules and Interfaces: Phi-Features Across Modules and Interfaces*. Ed. by Daniel Harbour, David Adger, and Susana Béjar. Oxford: Oxford University Press.
- Borer, Hagit (1984). *Parametric syntax: Case studies in Semitic and Romance languages*. Vol. 13. Walter de Gruyter GmbH & Co KG.
- (2004). The grammar machine. In: *The unaccusativity puzzle: Explorations of the syntax-lexicon interface*, pp. 288–331.
- Bosson, Georg (1985). *Empirische Universalienforschung*. Vol. 14. Narr.
- (1991). Differential object marking in Romance and beyond. In: *New analyses in Romance linguistics*, pp. 143–170.
- Burzio, Luigi (1986). Italian syntax. In: *Reidel, Dordrecht*.
- Chomsky, Noam (1981). *Lectures on Government and Binding*. Foris, Dordrecht.
- (1995). *The Minimalist Program*. Vol. 28. Cambridge Univ Press.
- (2000). Minimalist Inquiries: The Framework. In: *Step by Step. Essays on Minimalist Syntax in Honor of Howard Lasnik*. Ed. by Roger Martin, David Michaels, and Juan Uriagereka. Cambridge, MA: MIT Press, pp. 89–155.
- (2001). Derivation by Phase. In: *Ken Hale: A Life in Language*. Ed. by Michael Kenstowicz. Cambridge, MA: MIT Press, pp. 1–52.
- (2008). On phases. In: *Current Studies in Linguistics Series* 45, p. 133.
- (2013). Problems of projection. In: *Lingua* 130, pp. 33–49.
- (2014). *Problems of projection: extensions*. Ms.
- Comrie, Bernard (1979). Definite and Animate Direct Objects: A Natural Class. In: *Linguistica Silesiana* 3, pp. 13–21.
- Comrie, Bernard, Maria Polinsky, and Ramazan Rajabov (1998). *Tsezian Languages*. USC-UCSD, Los Angeles–San Diego.
- Coon, Jessica (2013). TAM Split Ergativity, Part I-II. In: *Language and Linguistics Compass* 7.3, pp. 171–190.

- Coon, Jessica and Omer Preminger (2017). Split Ergativity is not about Ergativity. In: *Oxford Handbook of Ergativity*. Ed. by Jessica Coon, Diane Massam, and Lisa Travis. New York: Oxford University Press.
- Corbett, Greville G (2006). *Agreement*. Vol. 109. Cambridge University Press.
- Croft, William (1988). Agreement vs. case marking and direct objects. In: *Agreement in natural language: Approaches, theories, descriptions*, pp. 159–179.
- Şener, Serkan (2008). Non-Canonical Case Licensing is Canonical: Accusative Subjects of CPs in Turkish. In: *Lingbuzz/000759*.
- Danon, Gabi (2011). Agreement and DP-internal feature distribution. In: *Syntax* 14.4.
- de Hoop, Helen and Andrej L Malchukov (2008). Case-marking strategies. In: *Linguistic Inquiry* 39.4, pp. 565–587.
- Demirdache, Hamida and Myriam Uribe-Etxebarria (2007). The syntax of time arguments. In: *Lingua* 117.2, pp. 330–366.
- Demirok, Ömer (2013). Agree as a Unidirectional Operation: Evidence from Laz. MA thesis. Boğaziçi University.
- Diesing, Molly (1992). Indefinites. In: *Linguistic Inquiry Monograph* 20.
- Dorleijn, Margreet (1996). *The Decay of Ergativity in Kurmanci*. Tilburg University Press.
- Enç, Mürvet (1991). The semantics of specificity. In: *Linguistic inquiry*, pp. 1–25.
- Erguvanlı Taylan, Eser and Balkız Öztürk (2014). Transitivity in Pazar Laz. In: *Acta Linguistica Hungarica* 61.3, pp. 271–296.
- Göksel, Asli (2005). Morphology and syntax inside the word: pronominal participles of headless relative clauses in Turkish. In: *Mediterranean Morphology Meetings*. Vol. 5, pp. 47–72.
- Göksel, Asli and Celia Kerslake (2004). *Turkish: A comprehensive grammar*. Routledge.
- Good, Jeff and Alan Yu (2005). Morphosyntax of two Turkish subject pronominal paradigms. In: *Clitic and affix combinations: Theoretical perspectives* 74, pp. 315–374.
- Grimshaw, Jane B (1991). Extended Projection. Brandeis University, Waltham, Mass.
- (2005). *Words and structure*. CSLI, Stanford University.
- Gündoğdu, Songül (2011). The Phrase Structure of Two Dialects of Kurmanji Kurdish. MA thesis. Boğaziçi University.
- Haggard, Gary, John Schlipf, and Sue Whitesides (2005). *Discrete mathematics for computer science*. Brooks/Cole-Thomson Learning.
- Haig, Geoffrey LJ (2008). *Alignment Change in Iranian Languages: A Construction Grammar Approach*. Walter de Gruyter.
- Halle, Morris and Alec Marantz (1993). Some key features of Distributed Morphology. In: *MIT working papers in linguistics* 21.275, p. 88.
- Harley, Heidi and Elizabeth Ritter (2002). Person and Number in Pronouns: A Feature-geometric Analysis. In: *Language* 78.3, pp. 482–526.
- Higginbotham, James (1983). Logical form, binding, and nominals. In: *Linguistic inquiry* 14.3, pp. 395–420.
- Hiraiwa, Ken (2005). Dimensions of Symmetry in Syntax: Agreement and Clausal Architecture. PhD thesis. MIT.
- Holisky, Dee Ann (1991). Laz. In: *Indigenous Languages of the Caucasus*. Ed. by Alice C Harris. Vol. 1. Caravan Books.
- Holmberg, Anders (1986). *Word order and syntactic features in the Scandinavian languages and English*. Dept. of General Linguistics, University of Stockholm.
- Holmberg, Anders and Thorbjörg Hróarsdóttir (2003). Agreement and movement in Icelandic raising constructions. In: *Lingua* 113, pp. 997–1019.

- Holmberg, Anders and Thorbjörg Hróarsdóttir (2004). Agreement and movement in Icelandic raising constructions. In: *Lingua* 114.5, pp. 651–673.
- Jónsson, Jóhannes Gísli (2009). Covert nominative and dative subjects in Faroese. In: *Nordlyd* 36.2, pp. 142–164.
- Julien, Marit (2002). *Syntactic heads and word formation*. Oxford University Press.
- Kabak, Barış (2007). Turkish suspended affixation. In: *Linguistics*.
- Kalin, Laura (2016). *A new model of nominal licensing*. NYU Brown Bag Talk.
- (2017). Dropping the F-bomb: An argument for valued features as derivational time-bombs. In: *NELS 47: Proceedings of the Forty-Seventh Annual Meeting of the North East Linguistic Society*. Ed. by Andrew Lamont and Katerina Tetzloff. Vol. 1. GLSA Publications, pp. 119–132.
- (2018). Licensing and Differential Object Marking: The View from Neo-Aramaic. In: *Syntax* 21.2, pp. 112–159.
- Kalin, Laura and Ümit Atlamaz (2015). Reanalyzing Indo-Iranian “stems”: A case study of Adıyaman Kurmanji. In: *Turkish, Turkic and the languages of Turkey*. UMass Amherst.
- Kalin, Laura and Coppe van Urk (2015). Aspect splits without ergativity. In: *Natural Language & Linguistic Theory* 33.2, pp. 659–702.
- Kalin, Laura and Philipp Weisser (2017). Asymmetric DOM in coordination and why this is fatal for movement-based approaches. In: *Manuscript*.
- Kayne, Richard S (1994). *The antisymmetry of syntax*. 25. mit Press.
- Keine, Stefan (2010). *Case and Agreement from Fringe to Core: A Minimalist Approach*. De Gruyter, pp. 661–669.
- Kornfilt, Jaklin (1977). A note on subject raising. In: *Linguistic Inquiry* 8, pp. 736–742.
- (1996). On some copular clitics in Turkish. In: *ZAS papers in linguistics* 6, pp. 96–114.
- (2012). Revisiting “Suspended Affixation” and Other Coordinate Mysteries. In: *Functional heads: The cartography of syntactic structures*. Ed. by Laura Brugé et al. Vol. 7. OUP.
- Kornfilt, Jaklin and Omer Preminger (2015). Nominative as no case at all: an argument from raising-to-accusative in Sakha. In: *Proceedings of the 9th Workshop on Altaic Formal Linguistics (WAFL9)/Ed. by Andrew Joseph and Esra Predolac (MIT Working Papers in Linguistics# 76)*. Cambridge (Mass), MIT Press, pp. 109–120.
- Kural, Murat (2005). Tree traversal and word order. In: *Linguistic Inquiry* 36.3, pp. 367–387.
- Laka, Itziar (1993). The Structure of Inflection: A case study in X0. In: *Generative studies in Basque linguistics* 105, p. 21.
- (1996). A brief grammar of Euskara, the Basque language. In:
- Lamontagne, Greg and Lisa Travis (1986). The case filter and the ECP. In: *McGill Working Papers in Linguistics* 3.2, pp. 51–75.
- Larson, Richard K (1988). On the double object construction. In: *Linguistic inquiry* 19.3, pp. 335–391.
- Launey, Michel (1981). *Introduction à la langue et à la littérature aztèques*.
- Legate, Julie Anne (2008). Morphological and abstract case. In: *Linguistic Inquiry* 39.1, pp. 55–101.
- Levin, Theodore (2018). On the nature of differential object marking. In: *Natural Language & Linguistic Theory*, pp. 1–47.
- Levin, Theodore and Omer Preminger (2015). Case in Sakha: are two modalities really necessary? In: *Natural Language & Linguistic Theory* 33.1, pp. 231–250.
- Lewis, Geoffrey (1967). *Turkish Grammar*. Oxford.

- Lockwood, William Burley (1955). *An introduction to modern Faroese*. Føroya.
- Mahajan, Anoop (1990a). The A/A-bar distinction and movement theory. PhD thesis. MIT.
- Mahajan, Anoop Kumar (1990b). The A/A-bar distinction and movement theory. PhD thesis. Massachusetts Institute of Technology.
- Marantz, Alec (1984). *On The Nature of Grammatical Relations*. Cambridge, MA: MIT Press.
- (1991). *Case and licensing*. Ms.
- Marušič, Franc, Andrew Nevins, and William Badecker (2015). The Grammars of Conjunction Agreement in Slovenian. In: *Syntax* 18.1, pp. 39–77.
- Miyagawa, Shigeru (2010). *Why Agree? Why Move: Unifying agreement-based and discourse configurational languages*. MIT Press.
- Moore, John (1998). Turkish copy-raising and A-chain locality. In: *Natural Language & Linguistic Theory* 16.1, pp. 149–189.
- Næss, Åshild (2004). What markedness marks: the markedness problem with direct objects. In: *Lingua* 114.9, pp. 1186–1212.
- Nevins, Andrew (2011). Multiple agree with clitics: Person complementarity vs. omnivorous number. In: *Natural Language & Linguistic Theory* 29.4, pp. 939–971.
- Nichols, Johanna (1986). Head-marking and dependent-marking grammar. In: *Language*, pp. 56–119.
- Nichols, Lynn (2001). The syntactic basis of referential hierarchy phenomena: Clues from languages with and without morphological case. In: *Lingua* 111.4-7, pp. 515–537.
- Noyer, Robert Rolf (1997). *Features, positions and affixes in autonomous morphological structure*. Garland. Revised version of 1992 MIT Doctoral Dissertation.
- Öztürk, Balkız (2013). Low, high and higher applicatives. In: *Information Structure and Agreement*. Ed. by Victoria Camacho-Taboada et al. John Benjamins Publishing Company, pp. 275–296.
- Öztürk, Balkız and Eser Erguvanlı Taylan (2017). Omnipresent little vP in Pazar Laz. In: *The Verbal Domain*. Ed. by Roberta D'Alessandro, Irene Franco, and Angel Gallego. Oxford University Press.
- Öztürk, Balkız and Markus A Pöchtrager (2011). *Pazar Laz*. LINCUM.
- Pesetsky, David and Esther Torrego (2007). The syntax of valuation and the interpretability of features. In: *Phrasal and clausal architecture: Syntactic derivation and interpretation*, pp. 262–294.
- Phillips, Colin (2003). Linear order and constituency. In: *Linguistic inquiry* 34.1, pp. 37–90.
- Polinsky, Maria and Eric Potsdam (2001). Long-distance agreement and topic in Tsez. In: *Natural Language & Linguistic Theory* 19.3, pp. 583–646.
- Preminger, Omer (2011). Asymmetries between person and number in syntax: a commentary on Baker's SCOPA. In: *Natural Language & Linguistic Theory* 29.4, pp. 917–937.
- (2014). *Agreement and its failures*. Vol. 68. MIT Press.
- (2019). What the PCC tells us about "abstract" agreement, head movement, and locality. In: *Glossa* 4.1, pp. 1–42.
- Rezac, Milan (2010). *Phi-features and the modular architecture of language*. Vol. 81. Springer Science & Business Media.
- Richards, Mark (2008). Defective Agree, Case Alternations, and the Prominence of Person. In: *Scales*. Ed. by Mark Richards and Andrej L Malchukov. Institut für Linguistik Universität Leipzig, pp. 137–162.
- Richards, Norvin Waldemar (1997). What moves where when in which languages? PhD thesis. Massachusetts Institute of Technology.



- Ritter, Elizabeth and Martina Wiltschko (2014). The composition of INFL. In: *Natural Language & Linguistic Theory* 32.4, pp. 1331–1386.
- Rizzi, Luigi (1990). *Relativized minimality*. The MIT Press.
- (1997). The fine structure of the left periphery. In: *Elements of grammar*. Springer, pp. 281–337.
- Ross, John Robert (1967). Constraints on Variables in Syntax. PhD thesis. MIT.
- Safir, Kenneth (2004). *The Syntax of (In)dependence*. Vol. 44. Linguistic Inquiry Monographs. MIT Press.
- Salanova, Andrés Pablo (2007). Nominalizations and aspect. PhD thesis. Massachusetts Institute of Technology.
- Schütze, Carson Theodore (1997). INFL in Child and Adult Language: Agreement, Case and Licensing. PhD thesis. Massachusetts Institute of Technology.
- Shlonsky, Ur (1989). The hierarchical representation of subject-verb agreement. In: *ms., University of Haifa*.
- Sigurðsson, Halldór Ármann (2004). Icelandic non-nominative subjects. In: *Typological Studies in Language* 61, pp. 137–160.
- Sigurðsson, Halldór Ármann and Anders Holmberg (2008). Icelandic dative intervention: Person and number are separate probes. In: *Agreement Restrictions*. Ed. by Roberta D'Alessandro, Susan Fischer, and Gunnar Hrafnbjargarson. Mouton De Gruyter, pp. 251–280.
- Silverstein, Michael (1976). Hierarchy of features and ergativity. In: *Grammatical categories in Australian languages*. Ed. by R. M. W. Dixon. Canberra: Australian Institute of Aboriginal Studies, 112–171.
- Stowell, Tim (2007). The syntactic expression of tense. In: *Lingua* 117.2, pp. 437–463.
- (2008). Where the Past is in the Perfect. In: *Tiempos compuestos y formas verbales complejas*. Ed. by Ángeles Carrasco Gutiérrez. Vervuert, pp. 103–118.
- Svenonius, Peter (2006). Case alternations and the Icelandic passive and middle. In: *Passives and impersonals in European languages*.
- Thackston, Wheeler M (2006). *Kurmanji Kurdish: A Reference Grammar with Selected Readings*. Renas Media.
- Thráinsson, Höskuldur (1994). Icelandic. In: *The Germanic Languages*. Ed. by Ekkehard König and Johan Van der Auwera. London: Routledge, pp. 142–189.
- (2007). *The Syntax of Icelandic*. Cambridge University Press.
- Torrego, Esther (1998). *The dependencies of objects*. Vol. 34. MIT Press.
- Trask, Robert (1979). On the Origins of Ergativity. In: *In Ergativity: Towards a theory of grammatical relations*. Ed. by Frans Plank. Academic Press, pp. 385–404.
- van Koppen, Marjo (2007). Agreement with Coordinated Subjects: A Comparative Perspective. In: *Linguistic variation yearbook* 7.1, pp. 121–161.
- van Urk, Coppe (2015). A uniform syntax for phrasal movement. PhD thesis. MIT.
- (to appear). Object Licensing in Fijian and the Role of Adjacency. In: *Natural Language & Linguistic Theory*.
- Vergnaud, J (2008). Letter to Noam Chomsky and Howard Lasnik on “Filters and Control,” April 17, 1977. In: *Current Studies in Linguistics Series* 45, p. 3.
- von Stechow, Kai (2012). Subjunctive Conditionals. In: *The Routledge Companion to Philosophy of Language*. Ed. by Gillian Russell and Delia Graff Fara. New York and London: Routledge, pp. 466–477.
- Wali, Kashi and Omkar Nath Koul (1997). *Kashmiri: A cognitive-descriptive grammar*. Psychology Press.

- Weisser, Philipp (2017). On the Symmetry of Case in Conjunction. In: *Manuscript*.
- Woolford, Ellen (1997). Four-way case systems: Ergative, nominative, objective and accusative. In: *Natural Language & Linguistic Theory* 15.1, pp. 181–227.
- Wurmbrand, Susi (2012). The syntax of valuation in auxiliary-participle constructions. In: *Coyote Papers: Working Papers in Linguistics, Linguistic Theory at the University of Arizona*.
- Zagona, Karen (1990). Times as temporal argument structure. In: *Unpublished ms., read at the conference 'Time in Language', Massachusetts Institute of Technology*.
- Zeijlstra, Hedde (2012). There is only one way to agree. In: *The Linguistic Review* 29, pp. 491–539.
- Zidani-Eroğlu, Leyla (1997). Exceptionally Case-Marked NPs as Matrix Objects. In: *Linguistic Inquiry* 28.2, pp. 219–230.